

Hydraulic seals – linear

INCH VERSION

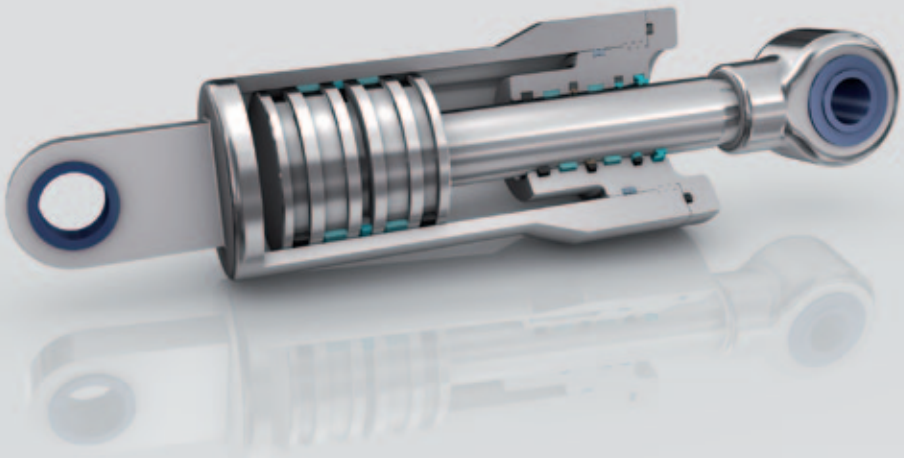



Your Partner for Sealing Technology

Trelleborg Sealing Solutions is a major international sealing force, uniquely placed to offer dedicated design and development from our market-leading product and material portfolio: a one-stop-shop providing the best in elastomer, thermoplastic, PTFE and composite technologies for applications in aerospace, industrial and automotive industries.

With 50 years experience, Trelleborg Sealing Solutions engineers support customers with design, prototyping, production, test and installation using state-of-the-art design tools. An international network of over 70 facilities worldwide includes 30 manufacturing sites and strategically positioned research and development centers, including materials and development laboratories and locations specializing in design and applications.

Developing and formulating materials in-house, we utilize the resource of our material database, including over 2,000 proprietary compounds and a range of unique products.

Trelleborg Sealing Solutions fulfills challenging service requirements, supplying standard parts in volume or a single custom-manufactured component, through our integrated logistical support, which effectively delivers over 40,000 sealing products to customers worldwide.

Facilities are certified to ISO 9001:2000 and ISO/TS 16949:2002, with many manufacturing sites also working to QS9000 and VDA 6.1. Trelleborg Sealing Solutions is backed by the experiences and resources of one of the world's foremost experts in polymer technology: Trelleborg AB.

ISO 9001:2000

ISO/TS 16949:2002

ISO 9000

ISO 14001

The information in this brochure is intended to be for general reference purposes only and is not intended to be a specific recommendation for any individual application. The application limits for pressure, temperature, speed and media given are maximum values determined in laboratory conditions. In application, due to the interaction of operating parameters, maximum values may not be achieved. It is vital therefore, that customers satisfy themselves as to the suitability of product and material for each of their individual applications. Any reliance on information is therefore at the user's own risk. In no event will Trelleborg Sealing Solutions be liable for any loss, damage, claim or expense directly or indirectly arising or resulting from the use of any information provided in this brochure. While every effort is made to ensure the accuracy of information contained herewith, Trelleborg Sealing Solutions cannot warrant the accuracy or completeness of information.

To obtain the best recommendation for a specific application, please contact your local Trelleborg Sealing Solutions marketing company.

This edition supercedes all previous brochures.

This brochure or any part of it may not be reproduced without permission.

© All trademarks are the property of Trelleborg AB.

The turquoise color is a registered trademark of Trelleborg AB.

© 2007, Trelleborg AB. All rights reserved.

Hydraulic Seals – linear

Contents

Part I - Rod Seals

Part II - Piston Seals

Part III - Scrapers

Part IV - Slydring® - Wear Rings

Part V - Dualseal

Hydraulic Seals – linear

HYDRAULIC SEALS ROD SEALS

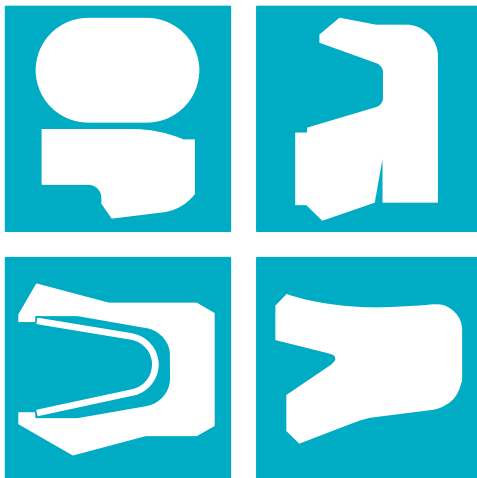



Rod Seals

Contents

Choice of the Sealing Element	4
Design Instructions	9
Installation Instructions	11
Quality Criteria	15
Storage Instructions	15
Turcon® Stepseal® 2K	17
Zurcon® U-Cup® RU9	29
Zurcon® Rimseal	37
Zurcon® Buffer Seal	45
Turcon® Glyd Ring® T	53
Turcon® Glyd Ring®	61
Turcon® Glyd Ring® C	69
Turcon® VL Seal®	79
Turcon® Variseal® M2	87
Turcon® Double Delta®	95
POLYPAC® - Balsele	103
Zurcon® L-Cup®	107
POLYPAC® Veepac CH/G5	111
POLYPAC® - Selemaster SM	115

■ Choice of the Sealing Element

Sealing elements have a decisive influence on the design, function and service life of hydraulic and pneumatic cylinders and systems.

This applies equally to the piston rod seals where leak tightness, resistance to wear and gap extrusion, resistance to process media, resistance to high and low temperatures, low friction, compact form and simple installation are demanded in order to meet the requirements of industry for a functional sealing solution.

The significance of these parameters and their limits generally depends on the requirements of the specific application. Trelleborg Sealing Solutions has therefore developed a complete range of seals which, due to their optimized geometries and designs and the use of high-quality materials such as Turcon® and Zurcon®, satisfy the technical and economic demands of the industry in full.

In order to be in a position to select the most appropriate seal type and material, it is necessary to first define all the desired functional parameters. Table I can then be used to make an initial selection of seals and materials according to the specific requirements of the application.

The second column of the table contains the number of the page on which further general information together with specific design and installation instructions on the particular seal type and materials (or material combinations with multi-element seals, e.g. Turcon® Stepseal® 2K) can be found.

Furthermore on page 10, attention is drawn to the quality of the mating surface. We recommend that the limits specified there be observed, as they have a decisive influence on the functionality and service life of the system.

The final choice of seal type and material must also take into account detailed information on the seal elements.

Please do not hesitate to contact our Technical Department for further information on specific applications and special technical questions.

This catalog is a compilation of the preferred product ranges of Trelleborg Sealing Solutions. All similar products are technically equivalent but availability and pricing may vary. For further information please contact your local Trelleborg Sealing Solutions sales office.

Note on Ordering

All multi-element standard rod seals, e.g. Turcon® Stepseal® 2K, are generally supplied as complete seal sets. The supply includes the seal and matching elastomer energizing elements. The O-Ring does not have to be ordered separately. It is also possible to use other O-Ring materials from our O-Ring catalog.

Older designs of seals no longer contained in this catalog naturally continue to be available (see chapter Non Standard Seals). For all new applications, however, we recommend the use of the seal types and preferred sizes (ISO series, wherever possible) listed in this catalog.





Other combinations of materials and special designs can be developed and supplied for special applications in all intermediate sizes up to 102 inches (2.600 mm) diameter, provided there is sufficient demand.

The sizes contained in this catalog are mostly available from stock or can be supplied at short notice. We reserve the right to modify our supply program.



Rod Seals







Table I Selection Criteria for Rod Seals

Seal		Application			Standard	Size Range	Action		Technical Data*			Recommended Seal Material
									Temp. Range **	Velocity	Pressure	
Type	Page	Field of Application			ISO/DIN	Inch	Single	Double	°F	Ft/s	PSI Max.	
		Light	Med	Heavy								
 Turcon® Stepseal® 2K	17	Mobile hydraulics	•	•	•	7425/2	.118-102	X	-49/ +392	50	10,150	Turcon® T46
		Standard cylinders	•	•	•						10,150	Turcon® T29
		Machine tools	•	•	•						3,625	Turcon® T05
		Injection molding machines	•	•	•							
		Presses	•	•	•							
		Automotive industry	•	•	•							
		Hydraulic hammers	•	•	•							
Servo hydraulic	•	•	•									
 Zurcon® U-Cup RU9	29	Industrial hydraulic	•	•	7425/2	.375-12	X	-31/ +230	1.65	6,000	Zurcon® Z20	
		Mobile hydraulic	•	•							Zurcon® Z22	
 Turcon® Rimseal	37	Mobile hydraulics	•	•	•	7425/2	.300-86	X	-49/ +212	In tandem with Turcon® Stepseal® 2K 16ft/s	In tandem 8,700 psi As single seal 3,625 psi	Zurcon® Z52
		Standard cylinders	•	•	•							
		Machine tools	•	•	•							
		Injection molding machines	•	•	•							
		Presses	•	•	•							
 Zurcon® Buffer Seal	45	Mobile hydraulic	•	•	7425/2	.375-12	X	-31/ +230	3.3	8,700	Zurcon® Z20	
											Zurcon® Z22	
 Glyd Ring® T	53	Special cylinder	•	•	•	7425/2	.118-102	X	-31/ +392	50	8,700	Turcon® T46
		Pumps and valves	•	•	•						3,625	Turcon® T40
		Machine tools	•	•	•							
		Robotics/manipulators	•	•	•							
		Hydraulic cylinders	•	•								

* The data below are maximum values and cannot be used at the same time. The max. pressure depends on temperature and gap dimension.

** Temperature range depends on choice of elastomer material and media.

Rod Seals



Seal		Application			Standard	Size Range	Action		Technical Data*			Recommended Seal Material
Type	Page	Field of Application					ISO/DIN	Inch	Single	Double	Temp. Range **	
		Light	Med.	Heavy	°F	Ft/s					PSI Max.	
 Glyd Ring®	61	Special cylinder	•	•	7425/2	.118-102	X		-49/ +392	50	8,700	Turcon® T46
		Pumps and valves	•	•							8,700	Turcon® T29
		Machine tools	•	•		2,900					Turcon® T05	
		Servo equipment	•	•		.118-86			-49/ +212	6.5	11,600	Zurcon® Z51
 Glyd Ring® C	69	Special cylinder	•	•	-	.125-20	X		-49/ +390	50	11,600	Turcon® T08
		Pumps and valves	•	•							8,700	Turcon® T46
		Machine tools	•	•							8,700	Turcon® T46
		Robotics/ manipulator	•	•							3,000	Turcon® T05
 Turcon® VL Seal	79	Hydraulic cylinder	•	•	-	.375-25	X		-49/ +390	50	8,700	Turcon® T46
		Mobile Hydraulics	•	•								
 Variseal® M2	87	High and low temperatures	•	•	-	.118-102	X		-94/ +500	50	6,500	Turcon® T40
		Aggressive media	•	•							2,900	Turcon® T05
		Foodstuff	•	•								
 Double Delta®	95	Valve stems	•	•	-	.118-102	X		-49/ +392	50	2,900	Turcon® T05
		Mini hydraulic	•	•							5,000	Turcon® T46
		Hydraulic tools	•	•							3,625	Turcon® T24
 Balsele	103	Hydraulic cylinder	•	•	5597/1	.400-47	X		-22/ +266	1.65	3,625	Rubber fabric reinforced + NBR
		Presses	•	•							With Back-up 5,800	
		Truck cranes	•	•								
 Zurcon® L-Cup	107	Hydraulic cylinder	•	•	5597/1	.236-10	X		-31/ +230	1.65	5,800	Zurcon® Z20
		Tail lift cylinder	•	•								
		Steering cylinder	•	•								

* The data below are maximum values and cannot be used at the same time. The max. pressure depends on temperature and gap dimension.

** Temperature range depends on choice of elastomer material and media.



Rod Seals

Seal		Application			Standard	Size Range	Action		Technical Data*			Recommended Seal Material	
									Temp. Range **	Velocity	Pressure		
Type	Page	Field of Application			ISO/DIN	Inch	Single	Double	°F	Ft/s	PSI Max.		
		Light	Med.	Heavy									
Veepac CH/G5 	111	Hydraulic cylinder	•	•	-	.787-40	X		-22/ +392	1.65	5,800	Rubber fabric reinforced + POM	
		Presses		•									•
		Mining		•									•
		Steel mills		•									•
		Water locks		•									•
Selemaster SM 	115	Hydraulic cylinder	•	•	-	.590-13	X		-40/ +266	1.65	10,150	Rubber fabric reinforced + POM	
		Presses		•									•
		Mining		•									•
		Steel mills		•									•
		Water locks		•									•

* The data below are maximum values and cannot be used at the same time. The max. pressure depends on temperature and gap dimension.

** Temperature range depends on choice of elastomer material and media.

Rod Seals

Redundant Sealing System

Sealing of environmentally harmful fluids has led Trelleborg Sealing Solutions to develop innovative sealing systems to meet the ever demanding industry specifications with regard to leak-free performance and high service life.

In heavy duty applications, leak free performance and high service life cannot be assured by a single sealing element; therefore, specially developed system seals are arranged in series, building a tandem arrangement.

Each sealing element in a system has its specific function and their interaction needs to be secured to get a redundant sealing system.

The primary seal in PTFE based proprietary Turcon® material generates low friction and has excellent wear and extrusion resistance under extreme working conditions. It allows a fine lubrication film passing this first barrier, ensuring the necessary lubrication of the secondary sealing element for long service life.

The tandem arrangement requires an outstanding back-pumping ability of the primary seal and the secondary seal, if a double acting scraper is installed. A combination of

different sealing materials in a system, Turcon® and Zurcon®, (PTFE and Polyurethane) ensures the best sealing performance.

Trelleborg Sealing Solutions has pioneered work in this area and continues development of redundant sealing today.

Outstanding solutions to such applications have been the Turcon® Stepseal® 2K in tandem arrangement. A tandem sealing system can also be created by using e.g. Zurcon® Rimseal, Zurcon® U-Cup RU9 or U-Cup as secondary sealing elements. Depending on type of secondary seal, a single- or double acting scraper completes the system, to offer the highest possible operation reliability, ensuring both adequate lubrication of the sealing system and a long service life.

Figure 1 shows an example of a redundant sealing system consisting of Turcon® Stepseal® 2K, Zurcon® Rimseal and Rod Scraper DA 22 with corresponding wear ring arrangement.

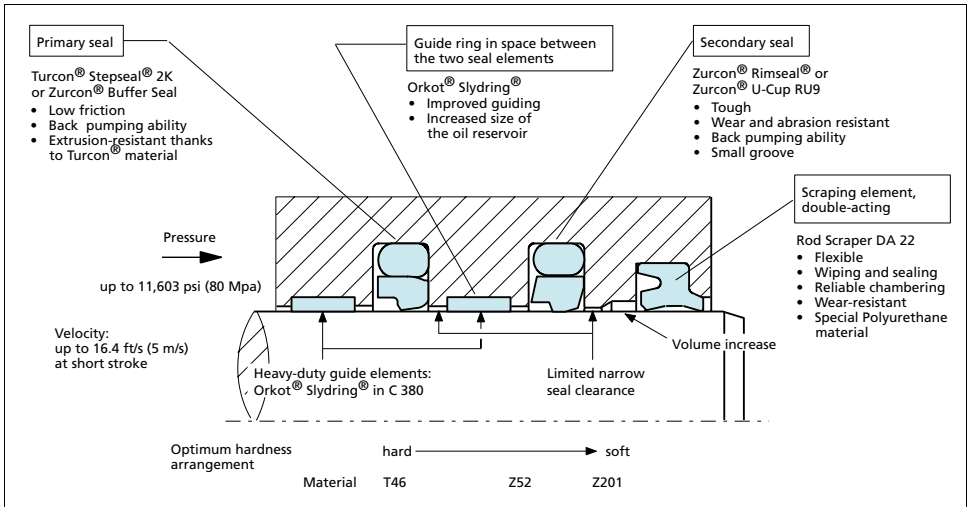

Figure 1 Example of a Redundant Modular Sealing System

■ Design Instructions

Lead-in Chamfers

In order to avoid damage to the rod seal during installation, lead-in chamfers and rounded edges must be provided on the piston rods (see Figure 2). If this is not possible for design reasons, a separate installation tool must be used.

The minimum length of the lead-in chamfer depends on the profile size of the seal and can be seen from the following tables.

Generally Δd_N min. from Table II is recommended but Δd_N must also exceed $0.015 \times$ rod diameter d_N (relevant for big diameter rods).

Table II Elastomer Energized**

Lead-in Chamfer Diameter reduction Δd min.	Groove Width L_1^*
.043	.090
.055	.126
.075	.165
.106	.250
.140	.319
.158	.374
.217	.543

* The dimension L_1 for the groove width can be found for all seal series in the appropriate table "Installation dimensions".

** Applies to product list Turcon® Stepseal 2K, Turcon® Glyd Ring and other O-ring energized products

Table III U-Cups, Variseal® and Buffer Seal

Lead-in Chamfer Diameter reduction Δd min.	U-Cups RU Groove Depth*	Turcon® Variseal® M2 Series
.043	.118 - .138 - .157	
.043	.197	
.055	.236 - .256	
.086	.295 - .315	RVA0
.106	.393	RVA1,RVA2
.137	.472	
.157	.590	RVA3
.216	.787	
.255		RVA4

* The groove depth is calculated from: $(d_1 - d)/2$. The dimensions for d_1 and d can be found in the tables, "Installation dimensions".

Table IV Turcon® Double Delta®

Lead-in Chamfer* Diameter reduction Δd min.	O-Ring Cross Section** d_2	
.043	.070	-
.055	.095	.103
.074	.118	.139
.106	.210	.225
.137	.275	.330

* Though not less than 1.5% of service diameter (bore/rod diameter).

** The O-Ring cross section d_2 can be found in the appropriate table "Installation Dimensions", from chapter Double Delta®.

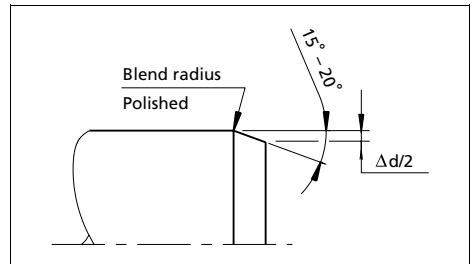

Figure 2 Lead-in chamfers

Distance between Grooves

When installing tandem seal arrangement or double-acting scraper seals in conjunction with rod seals with back pumping effects such as Turcon® Stepseal® 2K and Turcon® Rimseal, we recommend the following arrangement:

- Distance between seal grooves and/or scraper seal groove $L =$ at least groove depth X
- Oil reservoir for collecting the returning oil as shown in Figure 3.

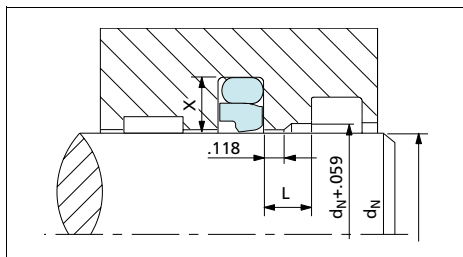

Figure 3 Recommendation for groove spacings between grooves

Surface Roughness DIN EN ISO 4287

The functional reliability and service life of a seal depend to a very great extent on the quality and surface finish of the mating surface to be sealed.

Scores, scratches, pores and concentric or spiral machining marks are not permitted. Higher demands must be made on the surface finish of dynamic surfaces than of static mating surfaces.

The characteristics most frequently used to describe the surface microfinish R_a , R_z and R_{max} are defined in DIN EN ISO 4287. These characteristics alone, however, are not sufficient for assessing the suitability in seal technology. In addition, the material contact area of the surface roughness profile R_{mr} in accordance with DIN EN ISO 4287 should be demanded. The significance of this surface specification is illustrated in Fig. 4. It shows clearly that specification of R_a and R_z alone do not describe the surface roughness profile accurately enough for the seal technology and is thus not sufficient for assessing the suitability. The material contact area R_{mr} is essential for assessing surfaces, as this parameter is determined by the specific surface roughness profile. This in turn is directly dependent on the machining process employed.

Trelleborg Sealing Solutions recommends that the following surface finishes be observed:

Table V Surface Roughness

Parameter	Surface Roughness μinch		
	Mating Surface		Groove Surface
	Turcon® Materials	Zurcon® and Rubber	
R_{max}	25 - 100	40 - 160	< 625
R_{zDIN}	16 - 63	25 - 100	< 400
R_a	2 - 8	4 - 16	< 63

The material contact area R_{mr} should be approx. 50 to 70%, determined at a cut depth $c = 0.25 \times R_z$, relative to a reference line of C_{ref} . 5%.

Surface profile μinch	R_a	R_z	R_{mr}
closed profile form 	4	40	70%
open profile form 	8	40	15%

Figure 4 Profile forms of surfaces

Figure 4 shows two surface profiles, both of which exhibit nearly the same value for R_z in the test procedure. The difference becomes obvious only when the material contact area of the surface roughness profiles are compared. These show that the upper roughness profile with ($R_{mr} = 70\%$) has the better seal/mating surface ratio.

Hardware

For optimum performance Trelleborg Sealing Solutions recommends a piston rod of chrome-plated steel.

Material: preferably 42CrMo4V, purity class K3 to DIN 50602.

Induction hardened min. HRC 45
 Hardening depth min. 0.1 inches
 Ground and hard chrome-plated, coating thickness .0008 to .0012 inch, polished

Roughness R_a 4 to 12 μinch max. corresponding to N4 DIN/ISO 1302

Material contact area $R_{mr} = 50$ to 70%
 Cut depth $c = 0.25 \times R_z$

For other rod materials, special coatings and treatments, please contact your local Trelleborg Sealing Solutions Company.

■ Installation Instructions

The following points should be observed before installation of the seals:

- Ensure the piston rod has a lead-in chamfer; if not, use an installation sleeve
- Deburr and chamfer or round sharp edges, cover the tips of screw threads
- Remove machining residues such as chips, dirt and other foreign particles and carefully clean all parts
- The seals can be installed more easily if the rod is greased or oiled. Attention must be paid to the compatibility of the seal materials with these lubricants. Use only grease without solid additives (e.g. molybdenum disulphide or zinc sulphide).
- Use no sharp-edged installation tools

Installation in Split Grooves

Installation in split grooves is problem-free. The sequence of installation corresponds to the configuration of the seal, whereby the individual seal elements must not be allowed to twist. During final installation (insertion of the piston rod into the seal), elastomer or spring-energized seals must be sized. The piston rod itself can be used for this purpose, provided that it has a long lead-in chamfer, or use a sizing sleeve.

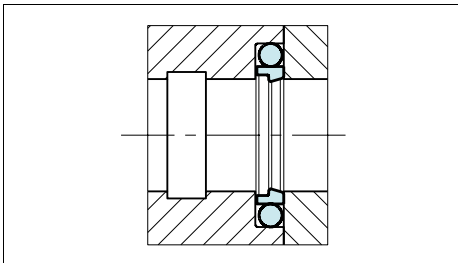

Figure 5 Installation in a split groove

Installation in Closed Grooves

By following the instructions in each seal type description (sizes for closed or split grooves) or using the light series for Turcon® seals, it will result in a problem-free installation of our rod seal elements of small diameters.

For Zurcon® and polyurethane (not Turcon®) seals, the use of installation tools is recommended. If installation has to be performed without installation tools, however, the following points should be observed:

- Place the O-Ring into the groove (not necessary with U-Cups)
- Compress the Turcon® or Zurcon® seals into a kidney shape. The seal must have no sharp bends (Figure 6)!

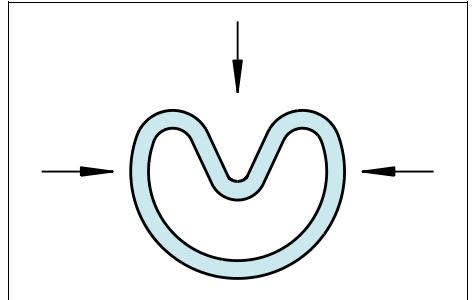

Figure 6 Kidney-shaped deformation of the seal ring

- Place the seal ring in compressed form into the groove and push against the O-Ring in the direction of the arrow (Figure 7).

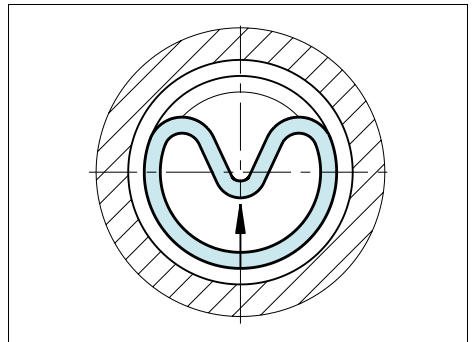

Figure 7 Inserting the seal ring into the closed groove

Rod Seals

- After placing into the groove, form the seal into a ring again in the groove by hand.
- Finally size the seal using a mandrel which should have a chamfer of 10° to 15° over a length of approx. 30 mm (1.181 inches)

The sizing mandrel should be made from a polymer material (e.g. polyamide) with good sliding characteristics and high surface quality in order to avoid damage to the seals.

The piston rod itself can also be used for calibration, provided it has a sufficiently long lead-in chamfer.

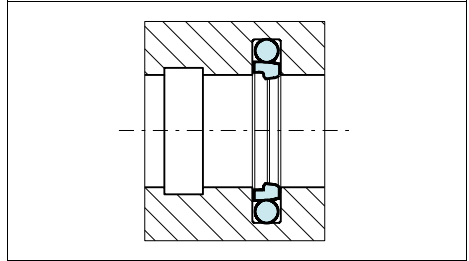

Figure 8 Installation in a closed groove

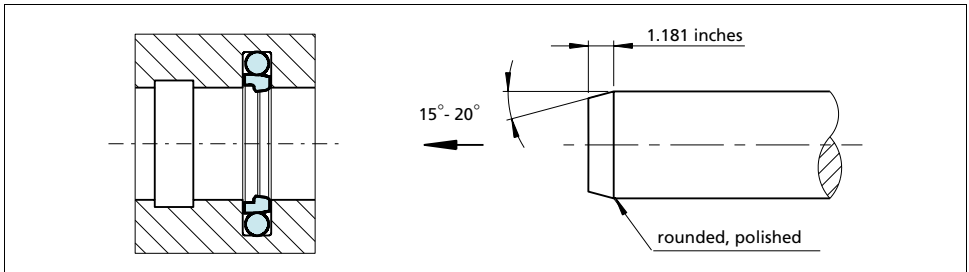

Figure 9 Calibration of the installed seal

Table VI Closed groove installation for Stepseal® 2K

Series	Stepseal® 2K can be installed in closed grooves above the following rod diameters and in the following Turcon® and Zurcon® materials *:	
	Rod Diameter $\varnothing_{d_N} \geq$	Materials
RSF0	.475	Turcon® T05, T08, T10, T29, T40, T42 and T46. Zurcon® Z51 and Z80
RSF1	.625	
RSF2	.750	
RSF3	1.500	
RSF4	2.750	
RSF5	7.875	
RSF8	10.000	
RSF6	25.500	

* For dimensions under $\varnothing 30$ mm (1.181 inches) and/or not very accessible grooves it is often imperative to use installation tools. Ask for further information.

Rod Seals

Installation of Turcon® Double Delta®

Installation in closed grooves is possible for diameters from 12 mm (.472 inches) using the following procedure:

- Place the O-Ring into the groove.
- Compress the Turcon® seal into a kidney shape, avoid making sharp bends on the seal (Figure 10).
- Place the seal ring in compressed form into the groove and push against the O-Ring in the direction of the arrow in the groove by hand (Figure 11).
For diameters smaller than 30 mm (1.181 inches) an inserter tube is recommended (Figure 12).
- Finally, size the seal ring using a mandrel which should have a chamfer of 10° to 15° over a min. length of 30 mm (1.181 inches) (Figure 13).

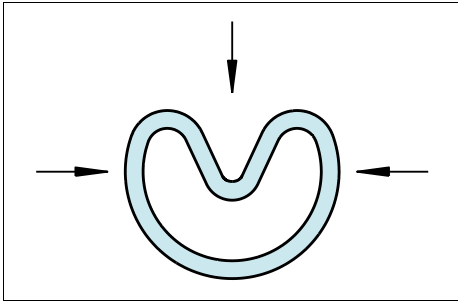

Figure 10 Kidney-shaped deformation

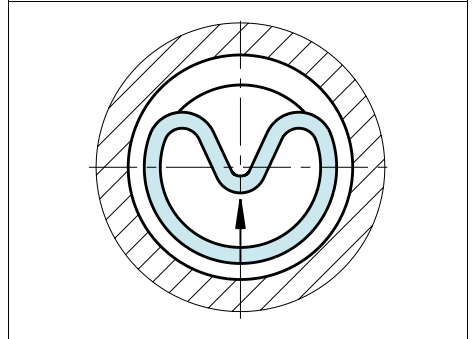

Figure 11 Inserting the seal ring into the closed groove

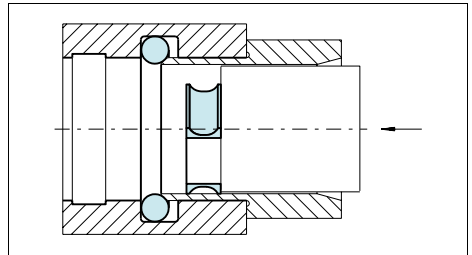

Figure 12 Insertion with an inserter tube

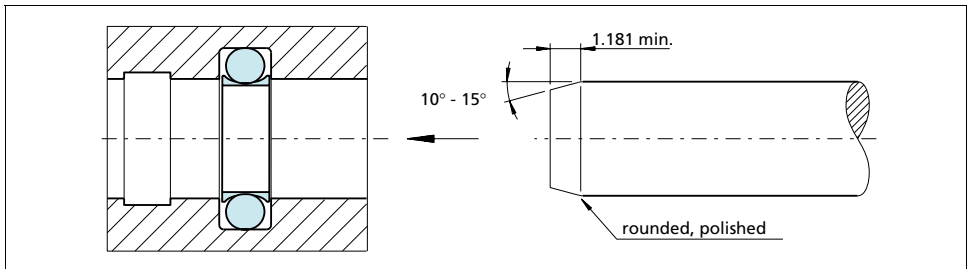

Figure 13 Calibration of the installed seal by means of a calibration mandrel

Rod Seals

Installation of Spring Energized Seals

Turcon® Variseal® M2 seals should preferably be installed in split grooves.

Installation in half-open grooves is possible with a snap fitting. Figure 14 shows the design of the groove.

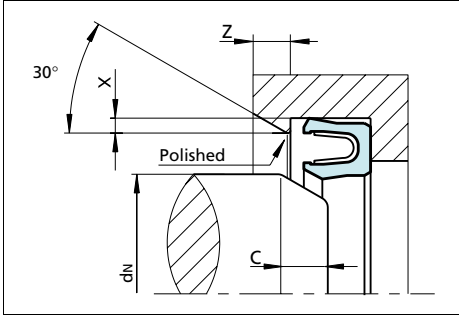

Figure 14 Installation in a half-open groove

Table VII Installation in Half-Open Grooves

TSS Serial-No.	X min.	d _N min.	Length C min.	Z min.
RVAA	.015	.472	.157	.098
RVAB	.023	.787	.196	.137
RVAC	.027	1.181	.196	.137
RVAD	.031	1.574	.295	.177
RVAE	.035	2.165	.472	.295
RVAF	.059	2.755	.472	.295

Further details, see Figure 46 and Table XXXII.

In exceptional cases or with existing designs, an installation in closed grooves is also possible. The details in Table VIII should be regarded as guide values for installation.

Table VIII Installation in Closed Grooves

TSS Serial-No.	d _N min.
RVAA	1.181
RVAB	2.755
RVAC	4.330
RVAD	11.810
RVAE	19.684
RVAF	31.495

■ Quality Criteria

The cost-effective use of seals and bearings is highly influenced by the quality criteria applied in production. Seals and bearings from Trelleborg Sealing Solutions are continuously monitored according to strict quality standards from material acquisition to delivery.

Certification of our production plants in accordance with international standards QS 9000 / ISO 9000 meets the specific requirements for quality control and management of purchasing, production and marketing functions.

Our quality policy is consistently controlled by strict procedures and guidelines which are implemented within all strategic areas of the company.

All testing of materials and products is performed in accordance with accepted test standards and specifications, e.g. random sample testing in accordance with DIN ISO 2859, part 1.

Inspection specifications correspond to standards applicable to individual product groups or manufacturing locations (e.g. for O-Rings: ISO 3601).

The tenth digit of our part number defines the quality characteristics of the part. A hyphen indicates compliance with standard quality criteria outlined in this catalog. Customer-specific requirements are indicated by a different symbol in this position. Customers who require special quality criteria should contact their local Trelleborg Sealing Solutions sales office for assistance. We have experience in meeting all customer quality requirements.

■ Storage information

Seals and bearings are often stored as spare parts for prolonged periods. Most rubbers change in physical properties during storage and ultimately become unserviceable due to excessive hardening, softening, cracking, crazing or other surface degradation. These changes may be the result of particular factors or combination of factors, such as deformation, oxygen, ozone, light, heat, humidity or oils and solvents.

With a few simple precautions, the shelf life of these products can be considerably lengthened.

Fundamental instructions on storage, cleaning and maintenance of elastomeric seal elements are described in international standards, such as:

DIN 7716 / BS 3F68: 1977,
ISO 2230, or
DIN 9088

The standards give several recommendations for the storage and the shelf life of elastomers, depending on the material classes.

The following recommendations are based on the several standards and are intended to provide the most suitable conditions for storage of rubbers. They should be observed to maintain the optimum physical and chemical values of the parts:

Heat

The storage temperature should preferably be between +41°F and +77°F (+5°C and +25°C). Direct contact with sources of heat such as boilers, radiators and direct sunlight should be avoided.

If the storage temperature is below +59°F (+15°C), care should be taken to avoid distorting them during handling at that temperature as they may have stiffened. In this case the temperature of the articles should be raised to approximately +68°F (+20°C) before they are put into service.

Humidity

The relative humidity in the store room should be below 70%. Very moist or very dry conditions should be avoided. Condensation should not occur.

Light

Elastomeric seals should be protected from light sources, in particular direct sunlight or strong artificial light with an ultraviolet content. Individual storage bags offer the best protection as long as they are UV resistant.

It is advisable to cover any windows of storage rooms with a red or orange coating or screen.

Radiation

Precaution should be taken to protect stored articles from all sources of ionizing radiation likely to cause damage to stored articles.

Oxygen and ozone

Where possible, elastomeric materials should be protected from circulating air by wrapping, storage in airtight containers or by other suitable means.

As ozone is particularly deleterious to some elastomeric seals, storage rooms should not contain any equipment that is capable of generating ozone, such as mercury vapor lamps, high voltage electrical equipment, electric motors or other equipment which may give rise to electric sparks or silent electrical discharges. Combustion gases and organic vapor should be excluded from storage rooms as they may give rise to ozone via photochemical processes.

Deformation

Elastomeric materials should, wherever possible, be stored in a relaxed condition free from tension, compression or other deformation. Where articles are packed in a strain-free condition they should be stored in their original packaging.

Contact with liquid and semi-solid materials

Elastomeric seals should not be allowed to come into contact with solvents, oils, greases or any other semi-solid materials at any time during storage, unless so packed by the manufacturer.

Contact with metal and non-metals

Direct contact with certain metals, e.g. manganese, iron and particularly copper and its alloys, e.g. brass and compounds of these materials are known to have deleterious effects on some rubbers. Elastomeric seals should not be stored in contact with such metals.

Because of possible transfer of plasticizers or other ingredients, rubbers must not be stored in contact with PVC. Different rubbers should preferably be separated from each other.

Cleaning

Where necessary, cleaning should be carried out with the aid of soap and water or methylated spirits. Water should not, however, be permitted to come into contact with fabric-reinforced components, bonded seals (because of corrosion) or polyurethane rubbers. Disinfectants or other organic solvents, as well as sharp-edged objects, must not be used. The articles should be dried at room temperature and not placed near a source of heat.

Shelf life and shelf life control

The useful life of a elastomeric seals will depend to a large extent on the type of rubber. When stored under the recommended conditions (above sections) the below given shelf life of several materials should be considered.

AU, Thermoplastics	4 years
NBR, HNBR, CR	6 years
EPDM	8 years
FKM, VMQ, FVMQ	10 years
FFKM, Isolast®	18 years
PTFE, Turcon®	unlimited

Elastomeric seals should be inspected after the given period. After this, giving an extension period is possible.

Rubber details and components less than 1.5 mm (.059 inches) thick are liable to be more seriously affected by oxidation degradation even when stored in satisfactory conditions as recommended. Therefore they may be inspected and tested more frequently than mentioned above.

Rubber details / seals in assembled components

It is recommended that the units should be exercised at least every six months and that the maximum period a rubber detail be allowed to remain assembled within a stored unit, without inspection, be a total of the initial period stated above and the extension period. Naturally this will depend on the design of the unit concerned.

TURCON[®] STEPSEAL[®] 2K



- Single-Acting -
- O-Ring-Energized Turcon[®] Slipper Seal -

- Material -
- Turcon[®] or Zurcon[®] -





■ Turcon® Stepseal® 2K*

Description

Rod seals must exhibit no dynamic leakage to the atmosphere side under all operating conditions and must be statically completely leak tight when the machine is at a standstill. Furthermore, they should achieve a high degree of mechanical efficiency through low friction and be easy to install in small grooves. Costs and service life must meet the high expectations of the operator.

The rod seal Turcon® Stepseal® 2K comes closest to satisfying these ideal demands. Since the first Stepseal® was patented and introduced to the market in 1972, Trelleborg Sealing Solutions has maintained the series of technically outstanding seal elements through continuous innovative development of the design and of the Turcon® and Zurcon® materials. Turcon® Stepseal® 2K continues the tradition for improvement.

With the introduction of Stepseal® it was possible for the first time to arrange several seals, one behind the other, thus allowing statically and dynamically tight double-acting tandem seal configurations to be created, without any disturbing build-up of intermediate pressure.

The single-acting seal element is made of high-grade Turcon® or Zurcon® materials with outstanding sliding and wear resistance properties. It is installed according to ISO 7425/2 and Trelleborg Sealing Solutions standard grooves, using an O-Ring as the energizing element.

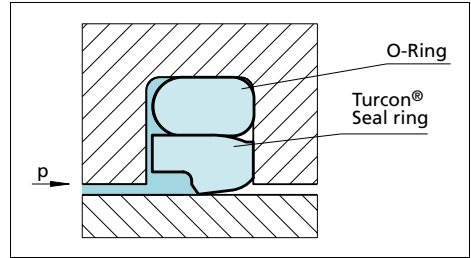

Figure 15 Turcon® Stepseal® 2K

Turcon® and Zurcon®
*Low friction, no stick-slip
 High form stability and wear resistance
 Meets demanding service conditions
 High flexibility for easy installation*

Elastomer O-Ring
High flexibility to compensate hardware tolerances and movement. Elastomer materials available to meet a wide variety of service conditions

Geometry
*Patented and patent pending geometry
 Proven seal edge design
 Resist damage during installation and service*

O-Ring Relief Chamfer
*Reduced seal load under pressure.
 Reduced seal friction*

Contoured Rear
*Improved back-pumping of residual oil film for increased sealing efficiency.
 Increased hardware tolerances
 Increased radial clearance*

* Patented and patent pending geometry



Method of operation

The sealing performance of Stepseal® 2K (Figure 15) results from the hydrodynamic properties of the seal. The classic Stepseal® seal edge creates a steep contact pressure gradient on the high pressure side and a shallow contact pressure gradient on the low pressure side. The controlled pressure gradients minimize fluid adherence to the piston rod during the extending stroke, and enables residual fluid film on the rod to be returned into the system on the return stroke. This is united with new patented design features which further improve the performance of Stepseal® 2K under severe service conditions.

The O-Ring relief chamfer reduces pressure loading on the seal, whereby contact with the rod is optimized and sealing performance is improved at high service pressures. The special high-lift rear chamfer combines a smooth downstream sealing face with the ability to meet large radial clearances and hardware tolerances.

Stepseal®2K gives high static and dynamic sealing performance, and the build-up of intermediate pressure often found with tandem seal configurations (see Figure 16) is efficiently suppressed.

- Available for all diameters up to 102 inches (2,600 mm) rod dia.

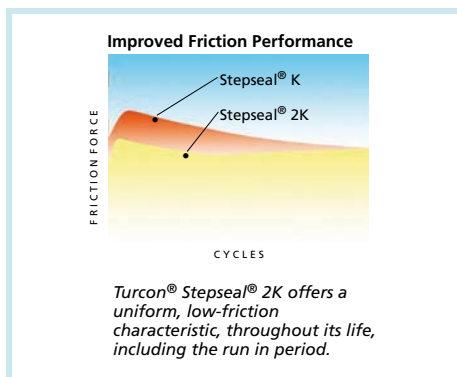

Technical data

Operating pressure: Up to 11,600 psi (80 MPa)

Velocity: Up to 50 ft/s (15 m/s) with reciprocating movements, frequency up to 5 Hz

Temperature: -49°F to +392°F (-45°C to +200°C) depending on O-Ring material)

Media: Mineral oil-based hydraulic fluids, flame retardant hydraulic fluids, environmentally safe hydraulic fluids (bio-oils), water and others, depending on the O-Ring material (see Table X)

Clearance: The maximum permissible radial clearance S_{max} is shown in Table XI, as a function of the operating pressure and functional diameter.

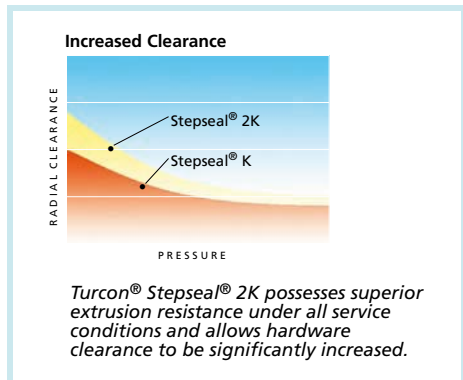

Advantages

- High static and dynamic sealing effect
- High extrusion resistance, meets high hardware clearances
- Low friction, high efficiency
- Stick-slip free starting, no sticking
- High abrasion resistance, high operational reliability
- Wide range of application temperatures and high resistance to chemicals, depending on the choice of O-Ring material
- Simple installation without seal edge deformation

Important Note:

The above data are maximum values and cannot be used at the same time. e.g. the maximum operating speed depends on material type, pressure, temperature and gap value. Temperature range also dependent on medium.



Materials

The following material combination has proven effective for applications with hydraulic oils containing zinc:

Seal Ring:	Turcon® T46	
O-Ring:	NBR, 70 Shore A	N
	FKM, 70 Shore A	V
Set code:	T46N/T46V	

For specific applications, other material combinations as listed in Table X, may also be used.

Series

Different cross section sizes are recommended as a function of the seal diameters. These are the criteria for these recommendations.

Table XI, shows the relationship between the series number according to the seal diameter range and the different application class sizes. These application classes are:

- Standard application: General applications in which no exceptional operating conditions exist
- Light-duty application: Applications with demands for reduced friction or for smaller grooves
- Heavy-duty application: For exceptional operating loads such as high pressures, pressure peaks, etc

Table IX Available range

Series No.	Rod Diameter d_N f8/h9
RSF00	.080 - 5.125
RSF10	.250 - 10.000
RSF20	.375 - 17.500
RSF30	.500 - 25.500
RSF40	1.500 - 25.500
RSF50	7.750 - 40.000
RSF80	10.000 - 48.000
RSF60	25.500 - 99.999

For the recommended range see Table XI.

Application Examples

- Mobile hydraulic
- Standard cylinders
- Machine tools
- Injection molding machines
- Presses
- Automobile industry
- Hydraulic hammers
- Servo hydraulics

Redundant Sealing System

In many applications, secondary seal systems are demanded. Figure 16 shows such a tandem configuration with the Stepseal® 2K.

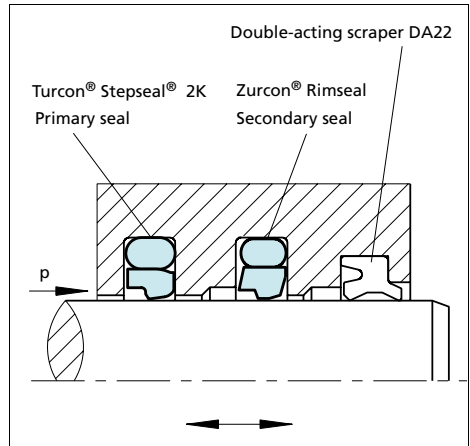

Figure 16 Turcon® Stepseal® 2K and Zurcon® Rimseal in tandem configuration

In this configuration it must be noted that a sufficiently large space is formed between the seals to take the hydraulic fluid, as shown in the figure.

Depending on the application and the operating conditions, the combination of different materials offers a further improvement in the sealing efficiency and the service life of the system, e.g. in hydraulic cylinders subject to high loads and under rough operating conditions, the primary seal should be made of Turcon® and the secondary seal of Zurcon®.



Turcon® Stepseal® 2K

Stepseal®2K elements should always be used in combination with a double-acting scraper to provide an optimum sealing effect.

The scraper Turcon® Excluder® 2, Turcon® Excluder® 5, DA17, DA22 and DA24 are well suited to such applications. For further details, please refer to our "Scrapers" catalog.

Table X Turcon® and Zurcon® Materials for Stepseal® 2K

Material, Applications, Properties	Code	O-Ring Material	Code	O-Ring Operating Temp.* °F	Mating Surface Material	PSI Max.
Turcon® T46 Standard material for hydraulics, high compressive strength, good sliding and wear properties, good extrusion resistance, BAM tested. Bronze filled Color: Grayish to dark brown	T46	NBR-70 Shore A	N	-22 to +212	Steel, hardened Steel, chrome-plated Cast iron	10,152
		NBR-Low temp. 70 Shore A	T	-49 to +176		
		FKM-70 Shore A	V	-14 to +392		
Turcon® T08 Very high compressive strength, very good extrusion resistance. High bronze filled Color: Light to dark brown	T08	NBR-70 Shore A	N	-22 to +212	Steel, hardened Steel, chrome-plated Cast iron	11,603
		NBR-Low temp. 70 Shore A	T	-49 to +176		
		FKM-70 Shore A	V	-14 to +392		
Turcon® T40 For all lubricating and non-lubricating hydraulic fluids, hydraulic oils without zinc, water hydraulic, soft mating surfaces. Surface texture not suitable for gases. Carbon fiber filled Color: Gray	T40	NBR-70 Shore A	N	-22 to +212	Steel Steel, chrome-plated Cast iron Stainless steel Aluminium Bronze Alloys	4,351
		NBR-Low temp. 70 Shore A	T	-49 to +176		
		FKM-70 Shore A	V	-14 to +392		
		EPDM-70 Shore A	E**	-49 to +293		
Turcon® T29 For all lubricating and non-lubricating hydraulic fluids, hydraulic oils without zinc, soft mating surfaces, good extrusion resistance. Surface texture not suitable for gases. High carbon fiber filled Color: Gray	T29	NBR-70 Shore A	N	-22 to +212	Steel Steel, chrome-plated Cast iron Stainless steel Aluminium Bronze	10,152
		NBR-Low temp. 70 Shore A	T	-49 to +176		
		FKM-70 Shore A	V	-14 to +392		
		EPDM-70 Shore A	E**	-49 to +293		
Turcon® T05 For all lubricating hydraulic fluids, hard mating surfaces, very good slide properties, low friction. Color: Turquoise	T05	NBR-70 Shore A	N	-22 to +212	Steel, hardened Steel, chrome-plated	3,625
		NBR-Low temp. 70 Shore A	T	-49 to +176		
		FKM-70 Shore A	V	-14 to +392		
Turcon® T42 For all lubricating and non-lubricating hydraulic fluids, good chemical resistance, good dielectric properties. Glass fiber filled + MoS ₂ Color: Gray to blue	T42	NBR-70 Shore A	N	-22 to +212	Steel, hardened Steel, chrome-plated Cast iron	5,801
		NBR-Low temp. 70 Shore A	T	-49 to +176		
		FKM-70 Shore A	V	-14 to +392		
Turcon® T19 For all lubricating fluids and hydraulic oils without zinc, high sealing efficiency, good sliding and wear properties, mild to counter surface. Mineral fiber filled. Color: Dark green-gray	T19	NBR-70 Shore A	N	-22 to +212	Steel Steel, hardened Steel, chrome-plated Cast iron Stainless steel	5,076
		NBR-Low temp. 70 Shore A	T	-49 to +176		
		FKM-70 Shore A	V	-14 to +392		

* The O-Ring operation temperature is only valid in mineral hydraulic oil. BAM: Tested by "Bundesanstalt Materialprüfung, Germany".
 □ highlighted materials are standard. ** Material not suitable for mineral oils. *** max. Ø 102 inches (2600 mm)



Material, Applications, Properties	Code	O-Ring Material	Code	O-Ring Operating Temp.* °F	Mating Surface Material	PSI Max.
Zurcon® Z51*** For lubricating hydraulic fluids, high abrasion resistance, high extrusion resistance , limited chemical resistance. Cast polyurethane Color: Yellow to light-brown	Z51	NBR-70 Shore A	N	-22 to +212	Steel	11,603
		NBR-Low temp. 70 Shore A	T	-49 to +176	Steel, chrome-plated Cast iron Ceramic coating Stainless steel	
Zurcon® Z80 For lubricating and non-lubricating hydraulic fluids, high abrasion resistance, very good chemical resistance, limited temp. resistance. Ultra high molecular weight polyethylene Color: White to off-white	Z80	NBR-70 Shore A	N	-22 to +176	Steel	6,526
		NBR-Low temp. 70 Shore A	T	-49 to +176	Steel, chrome-plated Stainless steel Aluminium Bronze Ceramic coating	

* The O-Ring operation temperature is only valid in mineral hydraulic oil. BAM: Tested by "Bundesanstalt Materialprüfung, Germany".
 highlighted materials are standard. ** Material not suitable for mineral oils. *** max. Ø 102 inches (2600 mm)



■ Installation Recommendation (Inch Rod Series)

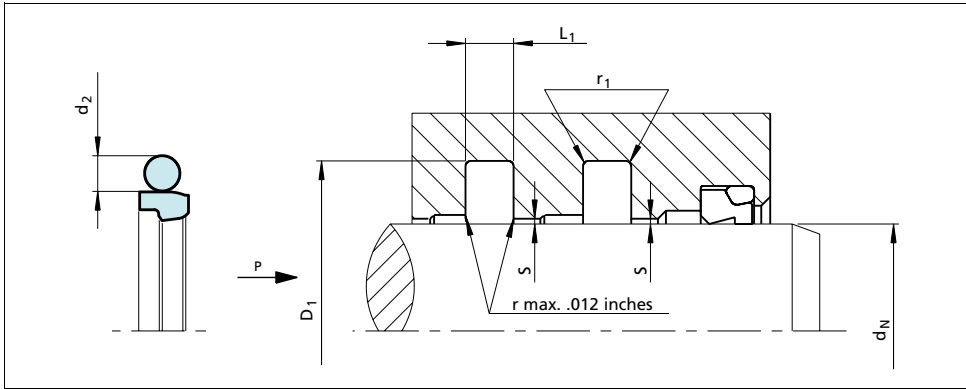

Figure 17 Installation drawing

Table XI Installation recommendation

TSS Series No.	Rod Diameter d_N f8/h9			Groove Diameter D_1 H9	Groove Width $L_1 + .008$	Radius r_1	Radial Clearance S max. *			O-Ring Cross-Section d_2
	Standard Application	Light ¹⁾ Application	Heavy Duty Application				10 MPa 1500 psi	20 MPa 3000 psi	40 MPa 5800 psi	
RSF0	.125 - .312	.313 - .749	-	$d_N + .193$.087	.016	.012	.008	.006	.070
RSF1	.313 - .749	.750 - 1.499	-	$d_N + .287$.126	.024	.016	.010	.006	.103
RSF2	.750 - 1.499	1.500 - 7.874	.313 - .749	$d_N + .421$.165	.039	.020	.012	.008	.139
RSF3	1.500 - 7.874	7.875 - 9.999	.750 - 1.499	$d_N + .594$.248	.051	.028	.016	.010	.210
RSF4	7.875 - 9.999	10.000 - 25.499	1.500 - 7.874	$d_N + .807$.319	.071	.031	.024	.014	.275
RSF5	10.000 - 25.499	25.500 - 39.999	7.875 - 9.999	$d_N + .945$.319	.071	.039	.031	.020	.275
RSF8	25.500 - 39.999	≥ 40.000	10.000 - 25.499	$d_N + 1.075$.374	.098	.035	.028	.016	.331
RSF6	≥ 40.000	-	25.500 - 39.999	$d_N + 1.496$.543	.118	.047	.035	.024	.472

* At pressures > 40 Mpa (5,800 psi) : use diameter tolerance H8/f8 (bore / rod) in the area behind the seal; or consult Trelleborg Sealing Solutions for alternative material or profiles.

1) For easier installation in closed grooves with small rod diameters (< 40 mm (1.575 inches)).



Ordering example

Turcon® Stepseal® 2K complete with O-Ring, standard application, Series RSF4 (from Table XI).

Rod diameter: $d_N = 8.000$ inches

TSS Part No.: RSF408000 (from Table XII)

Select the material from Table X. The corresponding code numbers are appended to the TSS Part No. (from Table XII). Together these form the TSS Article No.

The TSS Article No. for all intermediate sizes not shown in Table XII can be determined following the example below.

** For diameters ≥ 102 inches please consult your Trelleborg Sealing Solutions sales office for special TSS Article No.

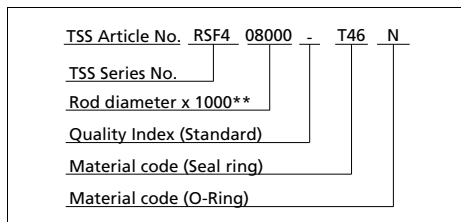

Notes:

- 1) Tolerances used are per ISO-286; ISO System of Limits and Fits. The tolerances are converted from metric and rounded to the nearest three decimal.
- 2) The clearances stated as S in the above table are for when the seal is specified with Slydring® bearings. When not incorporating Slydring® bearings, the diametral clearance should be reduced.
- 3) Consult your sales office for diameters that exceed those listed in the above table.

Table XII Installation dimensions / TSS Part No.

Rod Diameter	Groove Diameter	Groove Width	TSS Part No.
d_N f8/h9	D_1 H9	$L_1 + .008$	
.125	.318	.087	RSF000125
.188	.381	.087	RSF000188
.250	.443	.087	RSF000250
.313	.506	.087	RSF000313
.313	.600	.126	RSF100313
.375	.568	.087	RSF000375
.375	.662	.126	RSF100375
.438	.631	.087	RSF000438
.438	.725	.126	RSF100438
.500	.693	.087	RSF000500
.500	.787	.126	RSF100500
.563	.756	.087	RSF000563
.563	.850	.126	RSF100563
.625	.818	.087	RSF000625
.625	.912	.126	RSF100625
.688	.881	.087	RSF000688
.688	.975	.126	RSF100688
.750	.943	.087	RSF000750
.750	1.037	.126	RSF100750
.750	1.171	.165	RSF200750
.813	1.100	.126	RSF100813

Rod Diameter	Groove Diameter	Groove Width	TSS Part No.
d_N f8/h9	D_1 H9	$L_1 + .008$	
.813	1.234	.165	RSF200813
.875	1.162	.126	RSF100875
.875	1.296	.165	RSF200875
.938	1.225	.126	RSF100938
.938	1.359	.165	RSF200938
1.000	1.287	.126	RSF101000
1.000	1.421	.165	RSF201000
1.063	1.350	.126	RSF101063
1.063	1.484	.165	RSF201063
1.125	1.412	.126	RSF101125
1.125	1.546	.165	RSF201125
1.188	1.475	.126	RSF101188
1.188	1.609	.165	RSF201188
1.250	1.537	.126	RSF101250
1.250	1.671	.165	RSF201250
1.313	1.600	.126	RSF101313
1.313	1.734	.165	RSF201313
1.375	1.662	.126	RSF101375
1.375	1.796	.165	RSF201375
1.438	1.725	.126	RSF101438
1.438	1.859	.165	RSF201438



Turcon® Stepseal® 2K

Rod Diameter	Groove Diameter	Groove Width	TSS Part No.
d _N f8/h9	D ₁ H9	L ₁ + .008	
1.500	1.787	.126	RSF101500
1.500	1.921	.165	RSF201500
1.500	2.094	.248	RSF301500
1.563	1.984	.165	RSF201563
1.563	2.157	.248	RSF301563
1.625	2.046	.165	RSF201625
1.625	2.219	.248	RSF301625
1.688	2.109	.165	RSF201688
1.688	2.282	.248	RSF301688
1.750	2.171	.165	RSF201750
1.750	2.344	.248	RSF301750
1.813	2.234	.165	RSF201813
1.813	2.407	.248	RSF301813
1.875	2.296	.165	RSF201875
1.875	2.469	.248	RSF301875
1.938	2.359	.165	RSF201938
1.938	2.532	.248	RSF301938
2.000	2.421	.165	RSF202000
2.000	2.594	.248	RSF302000
2.125	2.546	.165	RSF202125
2.125	2.719	.248	RSF302125
2.250	2.671	.165	RSF202250
2.250	2.844	.248	RSF302250
2.375	2.796	.165	RSF202375
2.375	2.969	.248	RSF302375
2.500	2.921	.165	RSF202500
2.500	3.094	.248	RSF302500
2.625	3.046	.165	RSF202625
2.625	3.219	.248	RSF302625
2.750	3.171	.165	RSF202750
2.750	3.344	.248	RSF302750
2.875	3.296	.165	RSF202875
2.875	3.469	.248	RSF302875
3.000	3.421	.165	RSF203000
3.000	3.594	.248	RSF303000
3.125	3.546	.165	RSF203125

Rod Diameter	Groove Diameter	Groove Width	TSS Part No.
d _N f8/h9	D ₁ H9	L ₁ + .008	
3.125	3.719	.248	RSF303125
3.250	3.671	.165	RSF203250
3.250	3.844	.248	RSF303250
3.375	3.796	.165	RSF203375
3.375	3.969	.248	RSF303375
3.500	3.921	.165	RSF203500
3.500	4.094	.248	RSF303500
3.625	4.046	.165	RSF203625
3.625	4.219	.248	RSF303625
3.750	4.171	.165	RSF203750
3.750	4.344	.248	RSF303750
3.875	4.296	.165	RSF203875
3.875	4.469	.248	RSF303875
4.000	4.421	.165	RSF204000
4.000	4.594	.248	RSF304000
4.125	4.546	.165	RSF204125
4.125	4.719	.248	RSF304125
4.250	4.671	.165	RSF204250
4.250	4.844	.248	RSF304250
4.375	4.796	.165	RSF204375
4.375	4.969	.248	RSF304375
4.500	4.921	.165	RSF204500
4.500	5.094	.248	RSF304500
4.625	5.219	.248	RSF304625
4.625	5.432	.319	RSF404625
4.750	5.344	.248	RSF304750
4.750	5.557	.319	RSF404750
4.875	5.469	.248	RSF304875
4.875	5.682	.319	RSF404875
5.000	5.594	.248	RSF305000
5.000	5.807	.319	RSF405000
5.125	5.719	.248	RSF305125
5.125	5.932	.319	RSF405125
5.250	5.844	.248	RSF305250
5.250	6.057	.319	RSF405250
5.375	5.969	.248	RSF305375





Rod Diameter	Groove Diameter	Groove Width	TSS Part No.
d_N f8/h9	D_1 H9	$L_1 + .008$	
5.375	6.182	.319	RSF405375
5.500	6.094	.248	RSF305500
5.500	6.307	.319	RSF405500
5.625	6.219	.248	RSF305625
5.625	6.432	.319	RSF405625
5.750	6.344	.248	RSF305750
5.750	6.557	.319	RSF405750
6.000	6.594	.248	RSF306000
6.000	6.807	.319	RSF406000
6.250	6.844	.248	RSF306250
6.250	7.057	.319	RSF406250
6.500	7.094	.248	RSF306500
6.500	7.307	.319	RSF406500
6.750	7.344	.248	RSF306750
6.750	7.557	.319	RSF406750
7.000	7.594	.248	RSF307000
7.000	7.807	.319	RSF407000
7.250	7.844	.248	RSF307250
7.250	8.057	.319	RSF407250
7.500	8.094	.248	RSF307500
7.500	8.307	.319	RSF407500
7.750	8.344	.248	RSF307750
7.750	8.557	.319	RSF407750
8.000	8.807	.319	RSF408000
8.250	9.057	.319	RSF408250
8.500	9.307	.319	RSF408500
8.750	9.557	.319	RSF408750
9.000	9.807	.319	RSF409000
9.250	10.057	.319	RSF409250
9.500	10.307	.319	RSF409500
9.750	10.557	.319	RSF409750
10.000	10.807	.319	RSF410000
10.000	10.945	.319	RSF510000
10.500	11.307	.319	RSF410500
10.500	11.445	.319	RSF510500
11.000	11.807	.319	RSF411000

Rod Diameter	Groove Diameter	Groove Width	TSS Part No.
d_N f8/h9	D_1 H9	$L_1 + .008$	
11.000	11.945	.319	RSF511000
11.500	12.307	.319	RSF411500
11.500	12.445	.319	RSF511500
12.000	12.945	.319	RSF512000
12.500	13.445	.319	RSF512500
13.000	13.945	.319	RSF513000
13.500	14.445	.319	RSF513500
14.000	14.945	.319	RSF514000
14.500	15.445	.319	RSF514500
15.000	15.945	.319	RSF515000
15.500	16.445	.319	RSF515500
16.000	16.945	.319	RSF516000
16.500	17.445	.319	RSF516500
17.000	17.945	.319	RSF517000
17.500	18.445	.319	RSF517500
18.000	18.945	.319	RSF518000
18.500	19.445	.319	RSF518500
19.000	19.945	.319	RSF519000
19.500	20.445	.319	RSF519500
20.000	20.945	.319	RSF520000

The sizes listed in **bold** font are preferred sizes (more likely to be available for immediate shipment).



Turcon® Stepseal® 2K

ZURCON[®] U-CUP RU9

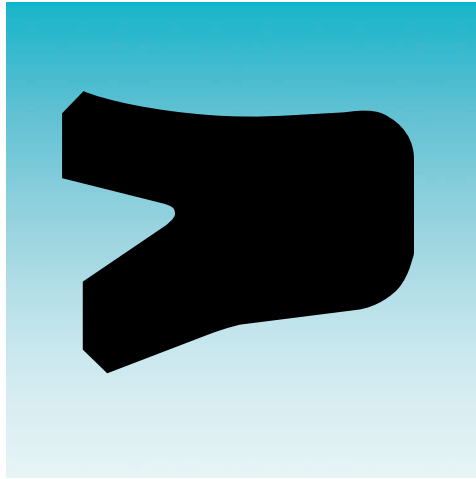

- Single-Acting -
- Low-friction Zurcon[®] U-Cup -

- Material -
- Zurcon[®] -





■ Zurcon® U-Cup RU9

Introduction

Rod seals are particularly exposed to pressure and friction. A long service life is a specific requirement of piston rods. Features such as wear and extrusion resistance, media and temperature compatibility, low friction, compact installation dimensions and ease of assembly are also essential and require the introduction of new products and materials. It is against this background that we have developed the Zurcon® U-Cup RU9.

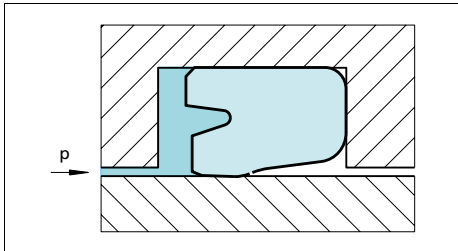

Figure 18 U-Cup, type RU9

Description

Due to its special design, behind the dynamic seal lip, the Zurcon® U-Cup RU9 with its structure of slide segments interspersed by back-pumping channels features, excellent back-pumping ability across the entire pressure range. The dynamic seal slide segments also have a micro-structure with excellent tribological and sealing characteristics. As well as increasing the sealing ability of the U-Cup RU9, this also ensures a constant lubrication film underneath the seal sliding surface, reducing breakaway force even after prolonged periods of rest, and reduces dynamic friction force.

■ Characteristics

Trimmed sealing lip
High interference
Excellent static tightness

Trimmed sealing lip
High dynamic and static tightness

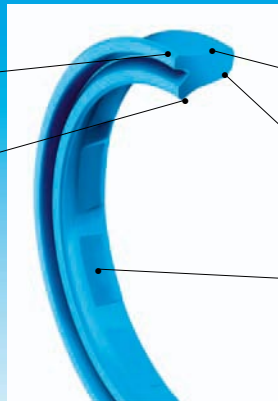

Expansion free space to reduce friction at the dynamic surface

Expansion free space for increased extrusion resistance

Slide segment for increased backpumping ability
Reduced friction
Low heat generation



Friction

The friction force of U-Cups dramatically increases between 362 and 1,450 psi. The Zurcon® U-Cup RU9 has a unique feature. As the system pressure increases, the contact surface between the U-Cup and the piston rod increases. Once a specific system pressure is reached, the seal deforms to such an extent that its entire friction-generating inside surface gets in contact with the piston rod. Due to the special design of Zurcon® U-Cup RU9 there is improved pressure distribution on the rod. The resulting tribological benefits restrict the increase in friction. When we compare the friction values of conventional U-Cups with those of the Zurcon® U-Cup RU9 the results are self-evident.

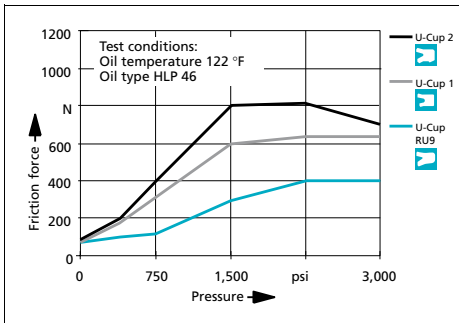

Figure 19 Friction dependent on pressure

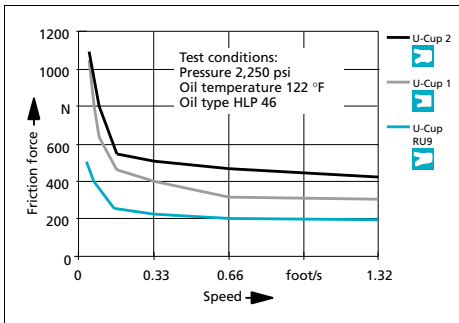

Figure 20 Friction dependent on speed

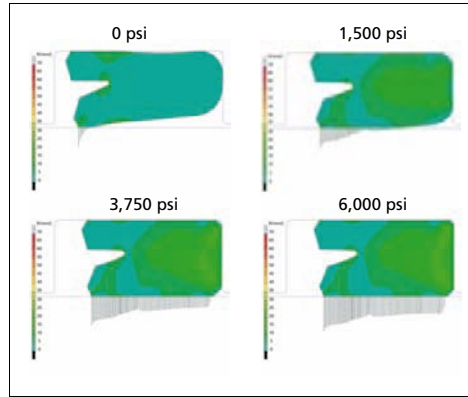

Figure 21 How the Zurcon® U-Cup RU9 performs under pressure

Sealing Performance

The high sealing performance is achieved by:

- Interference fit at the external diameter
- Special shape of both trimmed seal lips
- Controlled pressure distribution and hydrodynamic back-pumping ability over a wide pressure range

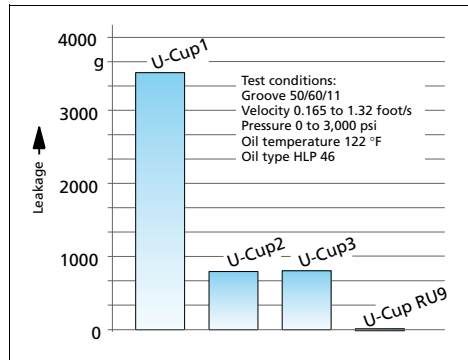

Figure 22 Leakage performance dependent on U-Cup type

Radial clearance

The new Zurcon® RU9 design combined with the special compound properties shows better extrusion resistance compared to a standard U-Cup under all working conditions. The hardware clearance can be increased significantly.

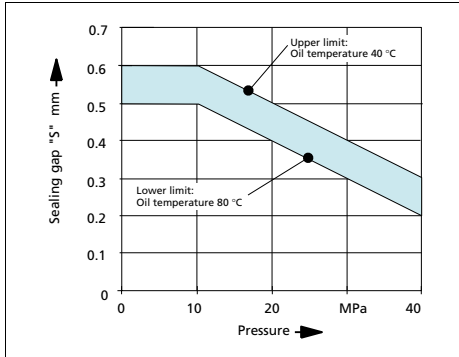

Figure 23 Radial clearance "S" as function of pressure

Advantages

- Lower friction than standard U-Cups
- Lower heat generation than standard U-Cups
- High extrusion resistance
- Excellent dynamic and static sealing
- Optimum environment protection
- Back pumping ability over the entire pressure range achieved by grooved profile
- Suitable with the Zurcon® Buffer Seal as secondary seal in tandem design
- Suitable for sealing systems with double scraper
- Seal stability within the groove

Application Examples

Zurcon® U-Cup RU9 can be used in all applications in which previously a conventional U-Cup was applied, such as:

- Hydraulic cylinders
- Construction machinery
- Fork lifts
- Truck cranes
- Telescopic cylinders
- Agricultural machines

- Machine tools
- Injection molding machines
- Hydraulic presses
- Gas spring

In medium/heavy duty applications the preferred solution for tandem rod sealing systems is the combination of the Zurcon® Buffer Seal primary seal and Zurcon® U-Cup RU9 in conjunction with a double acting scraper.

Materials

Zurcon® Z20 standard polyurethane 93 Shore A
Zurcon® Z22 premium polyurethane 93 Shore A

Color: Turquoise

The Zurcon® polyurethane has high abrasion resistance, a low compression set, high extrusion resistance and a wide temperature range.

Technical Data

Operating conditions:

Pressure: Up to 6,000 psi (40 MPa)

Velocity: Up to 1.65 ft/s (0.5 m/s)

Temperature:

Zurcon® Z20 Standard: -31°F to +230°F
(-35°C to +110°C)

Zurcon® Z22 Premium: -49°F to +230°F
(-45°C to +110°C)

Media:

Hydraulic fluids based on mineral oil: -31°F to +230°F
(-35°C to +110°C)

Synthetic and natural ester HEES, HETG: up to +140°F
(+60°C)

Flame-retardant hydraulic fluids HFA/HFB: up to +104°F
(+40°C)

Important Note:

The above stated limits for pressure and speed are maximum values individually. Friction heat generated by the combination of pressure and speed may cause local heat built-up. Care should be taken not to apply high values for pressure and speed at the same time.



■ Installation Recommendation (Inch Rod Series)

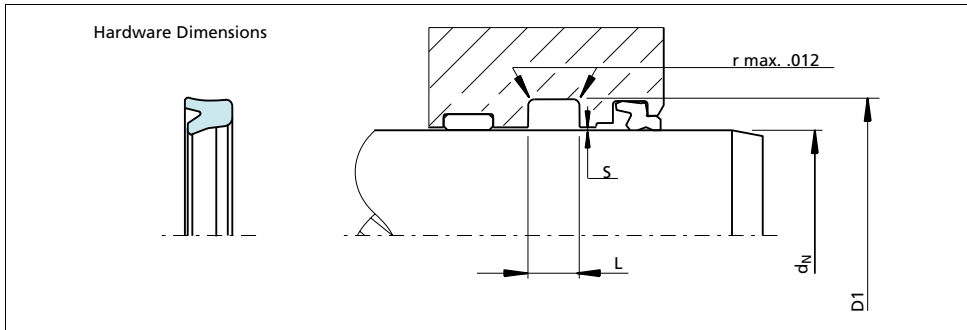

Figure 24 Installation drawing
Gap measure "S" see in Table XIII

Table XIII Installation dimensions – Standard recommendation

TSS Series No.	Rod Diameter		Groove Diameter	Groove Width	Radius	Radial Clearance		
	d_N f8/h9					S max.		
	Standard Application	Light Application				D_1 H10	$L_1 +.010$	r_1
RU9AC	.375 - .749	.750 - 1.250	$\phi d_N + .250$.250	.030	.023	.014	.006
RU9BF	.750 - 1.249	1.250 - 2.500	$\phi d_N + .375$.343	.030	.023	.014	.006
RU9CG	1.250 - 2.499	2.500 - 4.000	$\phi d_N + .500$.406	.030	.023	.014	.006
RU9DH	2.500 - 3.999	4.000 - 5.500	$\phi d_N + .625$.531	.030	.023	.014	.006
RUDEK	4.000 - 6.499	6.500 - 7.500	$\phi d_N + .750$.656	.030	.023	.014	.006
RU9FL	6.500 - 12.000	-	$\phi d_N + 1.000$.781	.030	.023	.014	.006

Ordering example (Inch)

Zurcon® U-Cup Type RU9

Rod diameter: $d_N = 2.500$ inches
 Groove diameter: $D_1 = 3.000$ inches
 Groove width: $L_1 = .406$ inches
 TSS Part No.: RU9CG02500

Material
 Standard Zurcon®: Z20
 Special polyurethane 93 Shore A
 Color: Turquoise

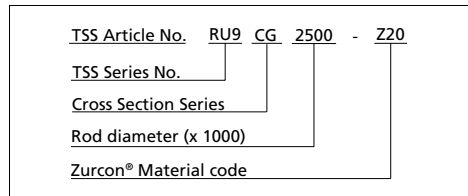

For other groove dimensions please contact your local Trelleborg Sealing Solutions sales office.

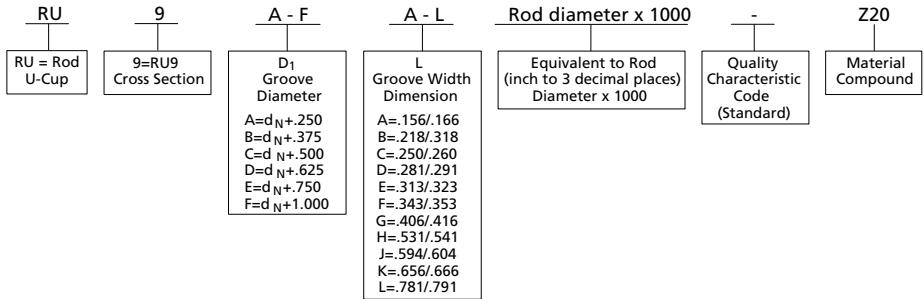

Table XIV Installation dimensions / TSS Part No

Rod Diameter d _N h9	Groove Diameter D ₁ H10	Groove Width L ₁ +.010	TSS Part No.
.500	.750	.250	RU9AC0500
.625	.875	.250	RU9AC0625
.750	1.000	.250	RU9AC0750
.875	1.125	.250	RU9AC0875
1.000	1.250	.250	RU9AC1000
1.125	1.500	.343	RU9BF1125
1.250	1.625	.343	RU9BF1250
1.375	1.750	.343	RU9BF1375
1.500	2.000	.406	RU9CG1500
1.625	2.125	.406	RU9CG1625
1.750	2.125	.343	RU9BF1750
1.750	2.250	.406	RU9CG1750
1.875	2.375	.406	RU9CG1875
2.000	2.375	.343	RU9BF2000
2.000	2.500	.406	RU9CG2000
2.125	2.625	.406	RU9CG2125
2.250	2.750	.406	RU9CG2250
2.375	2.875	.406	RU9CG2375
2.500	3.000	.406	RU9CG2500
2.625	3.125	.406	RU9CG2625
2.750	3.250	.406	RU9CG2750
3.000	3.500	.406	RU9CG3000
3.250	3.750	.406	RU9CG3250
3.375	3.875	.406	RU9CG3375

Rod Diameter d _N h9	Groove Diameter D ₁ H10	Groove Width L ₁ +.010	TSS Part No.
3.500	4.000	.406	RU9CG3500
3.750	4.250	.406	RU9CG3750
4.000	4.500	.406	RU9CG4000
4.500	5.125	.531	RU9DH4500
5.000	5.625	.531	RU9DH5000
5.500	6.125	.531	RU9DH5500
6.000	6.750	.656	RU9EK6000
6.500	7.250	.656	RU9EK6500
6.500	7.500	.781	RU9FL6500
7.000	8.000	.781	RU9FL7000
7.500	8.500	.781	RU9FL7500
8.000	9.000	.781	RU9FL8000

The sizes listed in **bold** font are preferred sizes (more likely to be available for immediate shipment).



Zurcon® U-Cup RU9

ZURCON[®] RIMSEAL

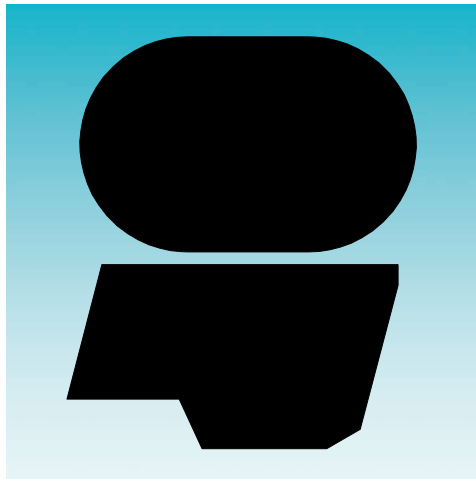

- Single-Acting -
- O-Ring-Energized Zurcon[®] Slipper Seal -

- Material -
- Zurcon[®] -





■ Zurcon® Rimseal

Description

When the field of application and system requirements make high demands on leakage control and operational reliability, a redundant sealing system is necessary to ensure reliable sealing of hydraulic cylinders at the piston rod. Sealing systems with elastomer-energized polymer seals are a proven answer to widely varying demands for standardized grooves, simple installation, resistance to media, high and low temperatures and pressures. The system offers enormous flexibility in the choice and matching of materials.

The piston rod sealing system for hydraulic cylinders subject to heavy loads should consist of three elements:

The Turcon® Stepseal®2K is used as primary seal. This seal element offers the back pumping property necessary for redundant rod seal systems as well as good resistance to high and low temperatures and high media resistance.

The Zurcon® Rimseal was developed as the secondary seal in this system to ensure reliable sealing of thin oil films at low secondary pressures. A Zurcon® material (polyurethane Shore D 58) is used combined with a new seal profile.

The contact pressure curve is automatically optimized under dynamic conditions.

The final outer element of the redundant sealing system is a double-acting scraper seal (e.g. DA 24, DA 22, DA 17, Turcon® Excluder® 2, Turcon® Excluder® 5).

The optimum sealing system thus consists of three independent lip seals installed in line, whereby the hardness of the material decreases from the pressure side to the atmospheric side.

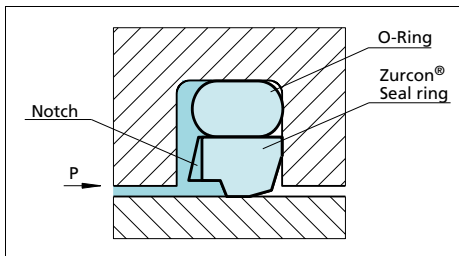

Figure 26 Zurcon® Rimseal

Method of Operation

The Zurcon® Rimseal is an O-Ring-energized seal element. The changes in seal position in the groove necessary for an optimum sealing function are guaranteed by the combination of the two component parts (O-Ring and seal ring).

In order to achieve a contact pressure curve which enhances the sealing effect, the seal has a chamfer on the low pressure side. When under pressure and exposed to friction against the piston rod, this chamfer causes the seal to tilt slightly so that the seal ring is forced against the side of the groove. This creates an area of maximum pressure at the edge of the seal.

When the Zurcon® Rimseal is used in a system with a double-acting scraper DA 24 (DA 22, DA 17, Excluder® 2, Excluder® 5), the sealing function of the system must be assured even if pressure build-up occurs between the Zurcon® Rimseal and the double-acting scraper seal.

For this reason, the high-pressure side of the seal ring also has a chamfer which, in the event of a build-up of pressure behind the Zurcon® Rimseal, comes into contact with the flank of the groove. The Zurcon® Rimseal moves in the groove so that a contact pressure distribution is obtained on the piston rod which enhances the back pumping effect.

Advantages

- High static and dynamic leak tightness
- Low friction for reduced power loss
- High wear resistance for long service life
- Small groove
- Easy installation
- Optimum system element
- ISO/DIN grooves optional
- Available for any diameter from .040 inches (8 mm) to 86.500 inches (2,200 mm)

Application Examples

- Mobile hydraulics
- Standard cylinders
- Machine tools
- Injection molding machines
- Presses



Technical Data

Pressure:	In tandem system: Up to 8,700 psi (60 MPa) As an individual element: 3,625 psi (25 MPa)
Velocity:	16.5 ft/s (5 m/s) with short strokes (<40.000 inches (1 m)) in tandem system
Temperature:	-49°F to +212°F (-45°C to +100°C) depending on O-Ring material
Media:	Hydraulic fluids -Mineral oil -Synthetic and natural esters -HEES. HETG up to +140°F (+60°C) -Flame retardant fluids HFA. HFC

Important Note:

The above data are maximum values and cannot be used at the same time. e.g. the maximum operating speed depends on material type, pressure, temperature and gap value. Temperature range also dependent on medium.

Materials

The Zurcon[®] Rimseal is made in the following material combinations as standard:

Seal ring:	Zurcon [®] Z52 Special polyurethane 58 Shore D
O-Ring:	NBR. 70 Shore A
Set code:	Z52N or Z52T

Series

The Zurcon[®] Rimseal is a system seal and is preferably used in tandem sealing systems in conjunction with the Turcon[®] Stepseal[®] 2K. The cross section series is identical with those for the Turcon[®] Stepseal[®] 2K.

Redundant Sealing System

Redundant sealing systems are used where the application conditions no longer permit reliable sealing over the demanded service life with a single seal.

The property of the tandem sealing system is particularly important during cold starts when, due to the very high viscosity of the oil, the primary seal allows oil to pass as the piston rod is extended. In the tandem system the oil is heated as a result of the friction at the primary seal and is then reliably wiped off - at a now lower viscosity - by the secondary seal, the Zurcon[®] Rimseal.

As the piston rod is retracted, the oil is stored in the reservoir between the seals, and is then pumped back against the system pressure by the hydrodynamics in the seal clearance of the Turcon[®] Stepseal[®] 2K.

Particularly with strokes of more than 40.000 inches (1 meter), constructional measures have to be taken to provide a storage chamber between the seals.

The Zurcon[®] Rimseal is designed so that it also has the back pumping properties necessary when using a double-acting scraper in the rod sealing system.

Due to the controlled sealing behavior of the individual elements in the sealing system and the appropriate combination of the seal materials, a rod seal system is obtained with a low overall friction.

The Figure 27 shows a redundant rod seal system consisting of Turcon[®] Stepseal[®] 2K, Zurcon[®] Rimseal and rod scraper DA 22 with corresponding wear ring arrangement.

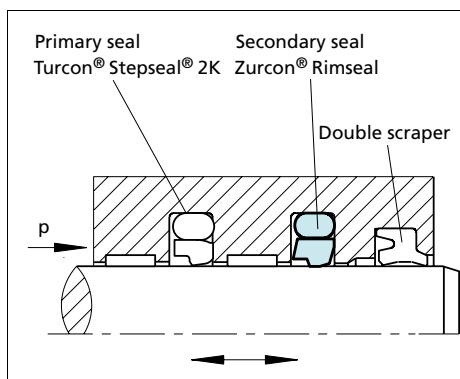

Figure 27 Zurcon[®] Rimseal in tandem configuration



■ Installation Recommendation (Inch Rod Series)

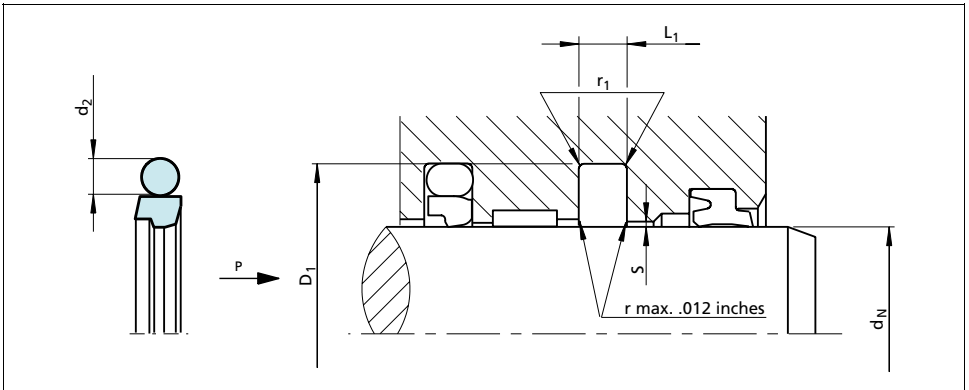

Figure 28 Installation drawing

Table XV Installation Recommendation

TSS Series No.	Rod Diameter d_N f8/h9			Groove Diameter D_1 H9	Groove Width $L_1 +.008$	Radius r_1	Radial Clearance S max.		O-Ring Cross-Section d_2
	Standard Application	Light Application	Heavy Duty Application				10 MPa 1500 psi	20 MPa 3000 psi	
RRF1	.313 - .749	.750 - 1.499	-	$d_N+.287$.126	.015	.015	.010	.103
RRF2	.750 - 1.499	1.500 - 7.999	.313 - .749	$d_N+.421$.165	.020	.015	.010	.139
RRF3	1.500 - 7.999	8.000 - 9.999	.750 - 1.499	$d_N+.594$.248	.030	.020	.012	.210
RRF4	8.000 - 9.999	10.000 - 25.500	1.500 - 7.999	$d_N+.807$.319	.035	.025	.015	.275
RRF5	10.000 - 25.500	-	8.000 - 10.000	$d_N+.945$.319	.035	.025	.015	.275

Ordering example

Zurcon® Rimseal complete with NBR O-Ring Series RRF4 (from table XV).

Rod diameter: $d_N = 8.000$ inches
 TSS Part No.: RRF408000 (from table XVI).

The TSS Part No. for all sizes not shown in table XVI can be determined following the example opposite.

** For diameters ≥ 102 inches please consult your Trelleborg Sealing Solutions sales office for special part no.

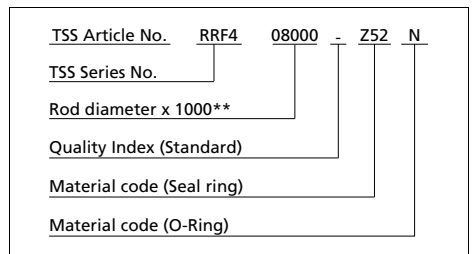

* Zurcon® Rimseal is always supplied as a set with a Nitrile O-Ring, code N or T.



Table XVI Installation dimensions / TSS Part No.

Rod Diameter	Groove Diameter	Groove Width	TSS Part No.
d _N f8/h9	D ₁ H9	L ₁ + .008	
.125	.318	.087	RRF000125
.188	.381	.087	RRF000188
.250	.443	.087	RRF000250
.313	.506	.087	RRF000313
.313	.600	.126	RRF100313
.375	.568	.087	RRF000375
.375	.662	.126	RRF100375
.438	.631	.087	RRF000438
.438	.725	.126	RRF100438
.500	.693	.087	RRF000500
.500	.787	.126	RRF100500
.563	.756	.087	RRF000563
.563	.850	.126	RRF100563
.625	.818	.087	RRF000625
.625	.912	.126	RRF100625
.688	.881	.087	RRF000688
.688	.975	.126	RRF100688
.750	.943	.087	RRF000750
.750	1.037	.126	RRF100750
.750	1.171	.165	RRF200750
.813	1.100	.126	RRF100813
.813	1.234	.165	RRF200813
.875	1.162	.126	RRF100875
.875	1.296	.165	RRF200875
.938	1.225	.126	RRF100938
.938	1.359	.165	RRF200938
1.000	1.287	.126	RRF101000
1.000	1.421	.165	RRF201000
1.063	1.350	.126	RRF101063
1.063	1.484	.165	RRF201063
1.125	1.412	.126	RRF101125
1.125	1.546	.165	RRF201125
1.188	1.475	.126	RRF101188
1.188	1.609	.165	RRF201188
1.250	1.537	.126	RRF101250
1.250	1.671	.165	RRF201250

Rod Diameter	Groove Diameter	Groove Width	TSS Part No.
d _N f8/h9	D ₁ H9	L ₁ + .008	
1.313	1.600	.126	RRF101313
1.313	1.734	.165	RRF201313
1.375	1.662	.126	RRF101375
1.375	1.796	.165	RRF201375
1.438	1.725	.126	RRF101438
1.438	1.859	.165	RRF201438
1.500	1.787	.126	RRF101500
1.500	1.921	.165	RRF201500
1.500	2.094	.248	RRF301500
1.563	1.984	.165	RRF201563
1.563	2.157	.248	RRF301563
1.625	2.046	.165	RRF201625
1.625	2.219	.248	RRF301625
1.688	2.109	.165	RRF201688
1.688	2.282	.248	RRF301688
1.750	2.171	.165	RRF201750
1.750	2.344	.248	RRF301750
1.813	2.234	.165	RRF201813
1.813	2.407	.248	RRF301813
1.875	2.296	.165	RRF201875
1.875	2.469	.248	RRF301875
1.938	2.359	.165	RRF201938
1.938	2.532	.248	RRF301938
2.000	2.421	.165	RRF202000
2.000	2.594	.248	RRF302000
2.125	2.546	.165	RRF202125
2.125	2.719	.248	RRF302125
2.250	2.671	.165	RRF202250
2.250	2.844	.248	RRF302250
2.375	2.796	.165	RRF202375
2.375	2.969	.248	RRF302375
2.500	2.921	.165	RRF202500
2.500	3.094	.248	RRF302500
2.625	3.046	.165	RRF202625
2.625	3.219	.248	RRF302625
2.750	3.171	.165	RRF202750





Rod Diameter	Groove Diameter	Groove Width	TSS Part No.
d_N f8/h9	D_1 H9	$L_1 + .008$	
2.750	3.344	.248	RRF302750
2.875	3.296	.165	RRF202875
2.875	3.469	.248	RRF302875
3.000	3.421	.165	RRF203000
3.000	3.594	.248	RRF303000
3.125	3.546	.165	RRF203125
3.125	3.719	.248	RRF303125
3.250	3.671	.165	RRF203250
3.250	3.844	.248	RRF303250
3.375	3.796	.165	RRF203375
3.375	3.969	.248	RRF303375
3.500	3.921	.165	RRF203500
3.500	4.094	.248	RRF303500
3.625	4.046	.165	RRF203625
3.625	4.219	.248	RRF303625
3.750	4.171	.165	RRF203750
3.750	4.344	.248	RRF303750
3.875	4.296	.165	RRF203875
3.875	4.469	.248	RRF303875
4.000	4.421	.165	RRF204000
4.000	4.594	.248	RRF304000
4.125	4.546	.165	RRF204125
4.125	4.719	.248	RRF304125
4.250	4.671	.165	RRF204250
4.250	4.844	.248	RRF304250
4.375	4.796	.165	RRF204375
4.375	4.969	.248	RRF304375
4.500	4.921	.165	RRF204500
4.500	5.094	.248	RRF304500
4.625	5.219	.248	RRF304625
4.625	5.432	.319	RRF404625
4.750	5.344	.248	RRF304750
4.750	5.557	.319	RRF404750
4.875	5.469	.248	RRF304875
4.875	5.682	.319	RRF404875
5.000	5.594	.248	RRF305000

Rod Diameter	Groove Diameter	Groove Width	TSS Part No.
d_N f8/h9	D_1 H9	$L_1 + .008$	
5.000	5.807	.319	RRF405000
5.125	5.719	.248	RRF305125
5.125	5.932	.319	RRF405125
5.250	5.844	.248	RRF305250
5.250	6.057	.319	RRF405250
5.375	5.969	.248	RRF305375
5.375	6.182	.319	RRF405375
5.500	6.094	.248	RRF305500
5.500	6.307	.319	RRF405500
5.625	6.219	.248	RRF305625
5.625	6.432	.319	RRF405625
5.750	6.344	.248	RRF305750
5.750	6.557	.319	RRF405750
6.000	6.594	.248	RRF306000
6.000	6.807	.319	RRF406000
6.250	6.844	.248	RRF306250
6.250	7.057	.319	RRF406250
6.500	7.094	.248	RRF306500
6.500	7.307	.319	RRF406500
6.750	7.344	.248	RRF306750
6.750	7.557	.319	RRF406750
7.000	7.594	.248	RRF307000
7.000	7.807	.319	RRF407000
7.250	7.844	.248	RRF307250
7.250	8.057	.319	RRF407250
7.500	8.094	.248	RRF307500
7.500	8.307	.319	RRF407500
7.750	8.344	.248	RRF307750
7.750	8.557	.319	RRF407750
8.000	8.807	.319	RRF408000
8.250	9.057	.319	RRF408250
8.500	9.307	.319	RRF408500
8.750	9.557	.319	RRF408750
9.000	9.807	.319	RRF409000
9.250	10.057	.319	RRF409250
9.500	10.307	.319	RRF409500



Rod Diameter	Groove Diameter	Groove Width	TSS Part No.
d_N f8/h9	D_1 H9	L_1 + .008	
9.750	10.557	.319	RRF409750
10.000	10.807	.319	RRF410000
10.000	10.945	.319	RRF510000
10.500	11.307	.319	RRF410500
10.500	11.445	.319	RRF510500
11.000	11.807	.319	RRF411000
11.000	11.945	.319	RRF511000
11.500	12.307	.319	RRF411500
11.500	12.445	.319	RRF511500
12.000	12.945	.319	RRF512000
12.500	13.445	.319	RRF512500
13.000	13.945	.319	RRF513000
13.500	14.445	.319	RRF513500
14.000	14.945	.319	RRF514000
14.500	15.445	.319	RRF514500
15.000	15.945	.319	RRF515000
15.500	16.445	.319	RRF515500
16.000	16.945	.319	RRF516000
16.500	17.445	.319	RRF516500
17.000	17.945	.319	RRF517000
17.500	18.445	.319	RRF517500
18.000	18.945	.319	RRF518000
18.500	19.445	.319	RRF518500
19.000	19.945	.319	RRF519000
19.500	20.445	.319	RRF519500
20.000	20.945	.319	RRF520000

The sizes listed in **bold** font are preferred sizes (more likely to be available for immediate shipment).

ZURCON[®] BUFFER SEAL

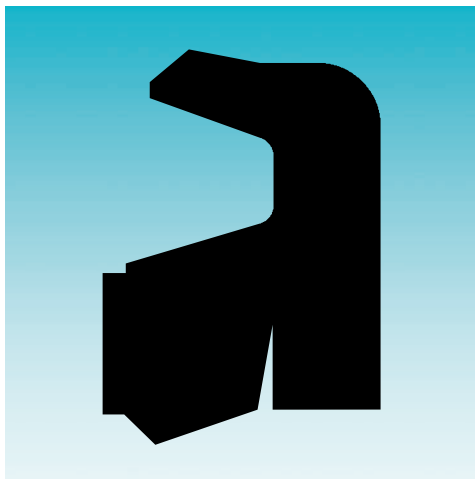

- Single-Acting -
- Zurcon[®] Rod Buffer Seal -
- with Integrated Back-up Ring -

- Material -
- Zurcon[®] -





■ Zurcon® Buffer Seal

Introduction

In heavy duty applications, leak-free performance and high service life cannot be assured by a single sealing element; therefore, specially developed system seals are arranged in series, building a tandem configuration.

Each sealing element in a system has its specific function and their interaction needs to be secured to get a redundant sealing system. The primary seal in Zurcon® material has excellent wear and extrusion resistance under extreme working conditions. It allows a fine lubrication film past this first barrier, ensuring the necessary lubrication of the secondary sealing element for long service life.

The tandem arrangement requires an outstanding back-pumping ability of the primary seal and the secondary seal, if a double acting scraper is installed.

Description

The single-acting Zurcon® Buffer Seal is designed as a heavy duty primary rod seal. The design of the product incorporates a combination of a Zurcon® sealing ring along with a back-up ring.

By utilizing two materials, the performance of the product is enhanced and life is extended. The Zurcon® Buffer Seal is designed in such a way that sealing performance is not compromised under system pressure extremes. At low system pressure, the resilience of the Zurcon® material allows for effective sealing. At high system pressure, the back-up ring is designed to contract into the extrusion gap, protecting the Zurcon® seal ring.

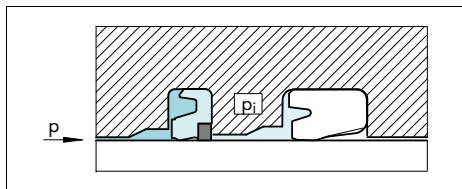

Figure 29 Tandem configuration

Friction

The Zurcon® Buffer Seal with its special U shape and its rounded dynamic lip is able to guarantee an optimal pressure distribution and a constant lubrication of the rod across the entire pressure range.

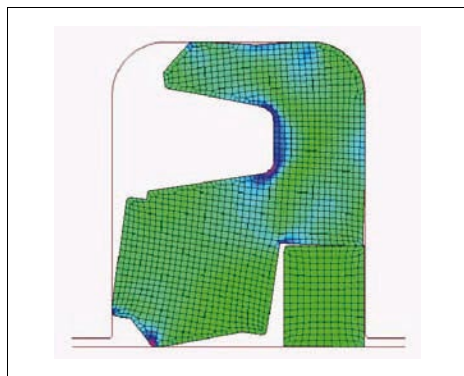

Figure 30 Zurcon® Buffer Seal un-pressurized

In un-pressurized conditions head-on slots on the dynamic lip assure right positioning avoiding any risk of blow-by. The Zurcon® Buffer Seal is ready for fast activation protecting the secondary seal from the peak of pressure.

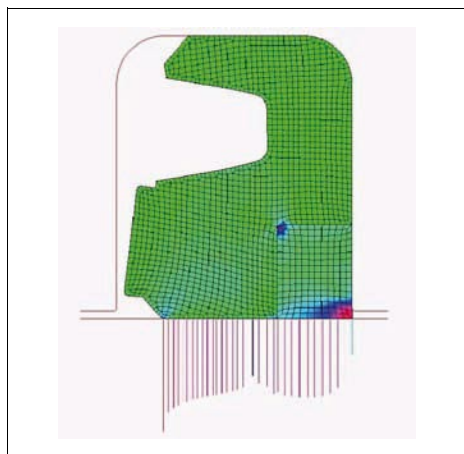

Figure 31 Pressure distribution at 5,800 psi (40 MPa)



Pressure relief

In a tandem configuration the Zurcon® Buffer Seal must assure quick and complete pressure relief in order to reduce friction and wear of the secondary seal. This increasing the life and overall sealing performance. The relief mechanism is activated by the special seal design through its thin, short and flexible static lip. The radial channels on the back side offer the fluid a direct stream up to both lips. A minimum difference between the pressure trapped and the pressure in the chamber is able to deflect the seal and recover the same pressure level.

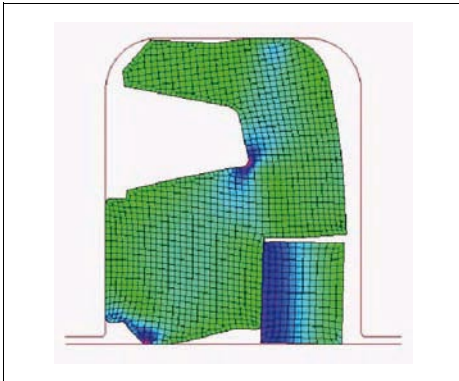

Figure 32 Pressure relief with a back pressure bigger of 72.5 psi (0.5 MPa)

Advantages

- Manufactured from Zurcon® and high-performance materials
- Conforms to ISO 7425/2 groove standards
- Suitable also for Stepseal® groove
- Excellent back-pumping over entire pressure range
- Resistant to high temperature and pressure
- Special design of dynamic seal lip for superior performance
- Designed with radial relief notches to prevent pressure trapping
- Superior wear and abrasion resistance
- Low compression set

Application Examples

Medium and heavy duty applications:

- Mobile equipment
- Lift trucks
- Earthmoving equipment

Materials - Standard application

For hydraulic components in mineral oils or medias with good lubricating performance

Seal ring:	Zurcon® Z20 standard polyurethane
Back-up ring:	Polyacetal resin (POM)
Set reference:	Z2054

Materials - Low temperature application

Seal ring:	Zurcon® Z22 premium polyurethane
Back-up ring:	Polyacetal resin (POM)
Set reference:	Z2254

Zurcon® polyurethane has high abrasion resistance, a low compression set, high extrusion resistance and a wide temperature range.



Technical Data

Operating conditions: The Zurcon® Buffer Seal is designed for high pressure rod sealing applications in extreme conditions.

Pressure: Up to 5,800 psi (40 MPa)
Up to 8,700 psi (60 MPa)
peak

Velocity: Up to 3.30 ft/s (1 m/s)

Temperature:
Zurcon® Z20 Standard: -31°F to +230°F
(-35°C to +110°C)

Zurcon® Z22 Premium: -49°F to +230°F
(-45°C to +110°C)

Media:
Hydraulic fluids based
on mineral oil: -31°F to +230°F
(-35°C to +110°C)

Synthetic and natural
ester HEES, HETG: Up to +140°F (+60°C)

Flame-retardant
hydraulic fluids
HFA/HFB: Up to +104°F (+40°C)

Important Note:

The above data are maximum values and cannot be used at the same time. e.g. the maximum operating speed depends on material type, pressure, temperature and gap value. Temperature range also dependent on medium.



■ Installation Recommendation (Inch Rod Series)

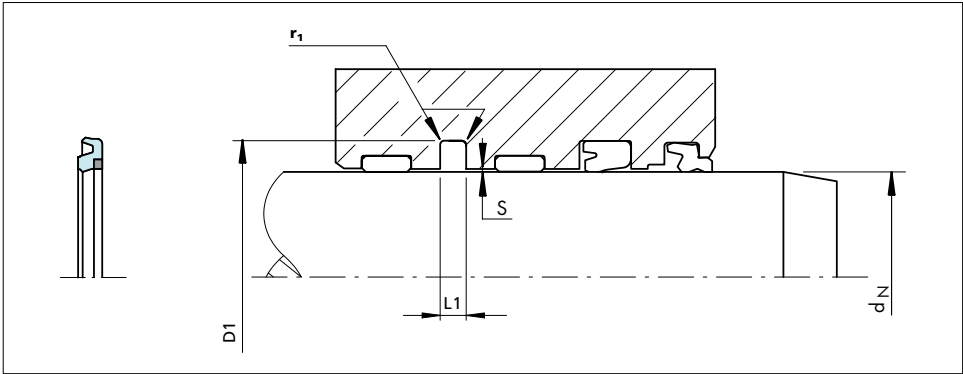

Figure 33 Installation drawing

Table XVII Installation Recommendation

TSS Series No.	Rod Diameter d_N f8/h9		Groove Diameter D_1 H9	Groove Width L_1 +.008	Radius r_1	Radial Clearance S max.		
	Standard Application	Light Application				10 MPa 1500 psi	20 MPa 3000 psi	40 MPa 5800 psi
RUH2	1.000 - 1.500	1.563 - 4.500	d_N + .421	.165	.025	.020	.012	.008
RUH3	1.563 - 4.500	4.625 - 7.750	d_N + .594	.248	.030	.028	.016	.010
RUH4	4.625 - 9.750	-	d_N + .807	.319	.035	.031	.024	.014

Ordering Example

TSS Series No.: RUH3B
 Rod diameter: d_N = 6.000 inches
 TSS Part No.: RUH3B6000

Material

Compound: Z2054
 (Zurcon® Z20 + POM Back-up ring)

Notes:

- 1) Tolerances used are per ISO-286; ISO System of Limits and Fits. The tolerances are converted from metric and rounded to the nearest three place decimal.
- 2) The clearance stated as S in the above table are for when the seal is specified with Slydring bearings. When not incorporating Slydring bearings, the diametral clearance should be reduced.
- 3) Consult your local Trelleborg Sealing Solutions sales office for diameters that exceed those listed in the above table.

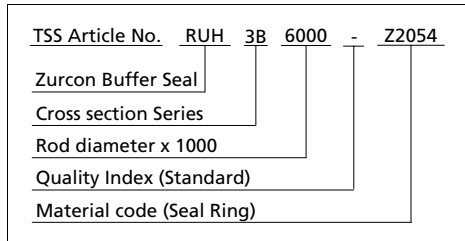



Table XVIII Installation dimensions / TSS Part No

Rod Diameter d_H f8/h9	Groove Diameter D_1 H9	Groove Width L_1 +.008	TSS Part No.
2.000	2.594	.248	RUH3B2000
2.250	2.844	.248	RUH3B2250
2.500	3.094	.248	RUH3B2500
2.750	3.344	.248	RUH3B2750
3.000	3.594	.248	RUH3B3000
3.250	3.844	.248	RUH3B3250
3.500	4.094	.248	RUH3B3500
3.750	4.344	.248	RUH3B3750
4.000	4.594	.248	RUH3B4000
4.500	5.094	.248	RUH3B4500
5.000	5.594	.248	RUH3B5000
5.500	6.094	.248	RUH3B5500
6.000	6.594	.248	RUH3B6000
6.500	7.094	.248	RUH3B6500
7.000	7.594	.248	RUH3B7000
8.000	8.807	.319	RUH4B8000

The sizes listed in **bold** font are preferred sizes (more likely to be available for immediate shipment).



Zurcon® Buffer Seal

TURCON[®] GLYD RING[®] T

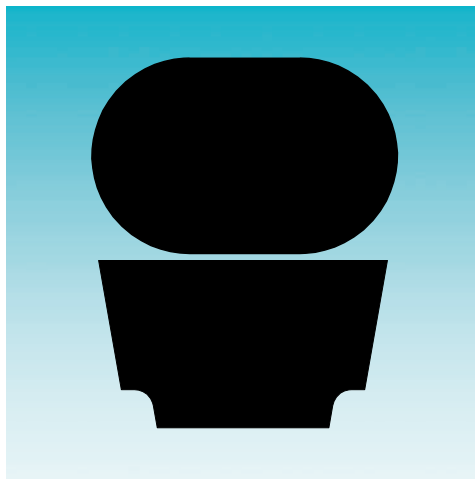

- Double-Acting -
- O-Ring-Energized Turcon[®] Slipper Seal -

- Material -
- Turcon[®] or Zurcon[®] -





■ Turcon® Glyd Ring® T*

Description

Turcon® Glyd Ring® T is a further technical development of the Turcon® Glyd Ring® seal which has been successfully used for decades. It is fully interchangeable with the earlier Glyd Ring® seals in all new applications. Glyd Ring® T meets all the market demands for a function-specific seal solution, observing economic and ecological aspects.

The benefits of the patented seal concept are provided by the innovative functional principle of the trapezoidal profile cross-section.

* Patent No.:

DE	41 40833 C3
EP	0 582 593
Japan	2 799 367
USA	5,433,452

Both lateral profile flanks are inclined so that the seal profile tapers towards the seal surface. The profile can thus retain the robust and compact form typical of piston seals without losing any of the flexibility required to achieve a pressure-related maximum compression (Figure 34).

The edge angle created by the special Glyd Ring® T cross-sectional form permits an additional degree of freedom and enables a slight tilting movement of the seal. The maximum compression is always shifted towards the area of the seal edge directly exposed to the pressure. On the low-pressure edge of the seal, on the other hand, the Glyd Ring® T exhibits only zones with neutral strains without compressive or shearing loads, effectively reducing the danger of gap extrusion. The resulting benefits for the user can be seen in the following list.

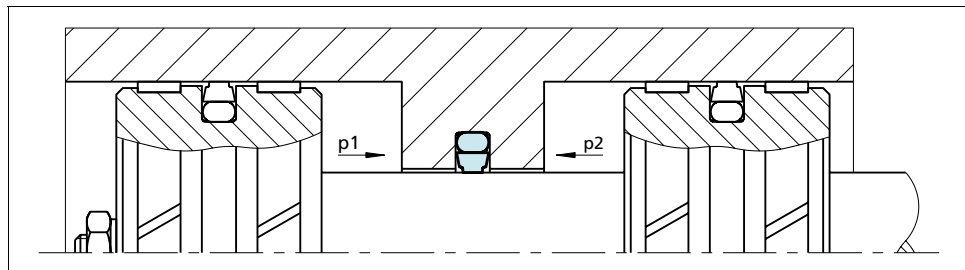

Figure 34 Turcon® Glyd Ring® T

Advantages

The benefits offered to date by the Glyd Ring® are still retained in full, and are now complemented by a number of further important advantages:

- Very good static leak-tightness
- Increased clearance possible (approx. +50%), depending on the operating conditions
- Low friction, no stick-slip effect
- Simple groove design
- Available for all rod diameters up to 102 inches (2,600 mm)

Application Examples

The Turcon® Glyd Ring® T is the recommended sealing element for double acting inside sealing seal for hydraulic components such as:

- Injection molding machines
- Machine tools
- Presses
- Handling machinery
- Agriculture
- Valves

It is particularly recommended for heavy duty and large diameter applications.



Turcon® Glyd Ring® T

Technical Data

Operating pressure:	Up to 11,600 psi (80 MPa)
Velocity:	Up to 50 ft/s (15 m/s)
Temperature:	-49°F to +392°F (-45°C to +200°C) (depending on O-Ring material)
Media:	Mineral oil-based hydraulic fluids, flame retardant hydraulic fluids, environmentally safe hydraulic fluids (bio-oils), water, air and others, depending on the O-Ring material (see Table XIX)
Clearance:	The maximum permissible radial clearance s_{max} is shown in Table XX as a function of the operating pressure and functional diameter.

Important Note:

The above data are maximum values and cannot be used at the same time. e.g. the maximum operating speed depends on material type, pressure, temperature and gap value. Temperature range also dependent on medium.

Materials

Standard Application:

- For hydraulic components with reciprocating movement in mineral oils containing zinc or medium with good lubricating performance

Seal Ring:	Turcon® T46
Energizer:	O-Ring NBR 70 shore A or FKM 70 Shore A depending on the temperature
Set code:	T46N or T46V

Special Application:

- Non-lubricating fluids or pneumatic applications require self-lubricating sealing materials. Therefore we recommend:

Seal Ring:	Turcon® T40
Energizer:	O-Ring NBR 70 Shore A or FKM 70 Shore A depending on the temperature
Set code:	T40N or T40V

- If rougher surface finish must be sealed, we recommend:

Seal Ring:	Zurcon® Z51
Energizer:	O-Ring NBR 70 Shore A
Set code:	Z51N



Table XIX Turcon® and Zurcon® Materials for Glyd Ring® T

Material, Applications, Properties	Code	O-Ring Material	Code	O-Ring Operating Temp.* °F	Mating Surface Material	PSI Max.
Turcon® T46 Standard material for hydraulics, high compressive strength, good sliding and wear properties, good extrusion resistance, BAM tested. Bronze filled Color: Grayish to dark brown	T46	NBR - 70 Shore A	N	-22 to +212	Steel, hardened Steel, chrome-plated Cast iron	8,700
		NBR - Low temp. 70 Shore A	T	-49 to +176		
		FKM - 70 Shore A	V	-14 to +392		
Turcon® T40 For all lubricating and non-lubricating hydraulic fluids, hydraulic oils without zinc, water hydraulic, soft mating surfaces, good extrusion resistance. Surface texture not suitable for gases. Carbon fiber-filled Color: Gray	T40	NBR - 70 Shore A	N	-22 to +212	Steel Steel, chrome-plated Cast iron Stainless steel Aluminium Bronze Alloys	3,625
		NBR - Low temp. 70 Shore A	T	-49 to +176		
		FKM - 70 Shore A	V	-14 to +392		
		EPDM - 70 Shore A	E**	-49 to +293		
Zurcon® Z51*** For lubricating hydraulic fluids, high abrasion resistance, high extrusion resistance , limited chemical resistance. Cast polyurethane Color: Yellow to light-brown	Z51	NBR - 70 Shore A	N	-22 to +212	Steel Steel, chrome-plated Cast iron Ceramic coating Stainless steel	11,600
		NBR - Low temp. 70 Shore A	T	-49 to +176		

* The O-Ring operation temperature is only valid in mineral hydraulic oil. BAM: Tested by "Bundesanstalt Materialprüfung, Germany".
 Highlighted materials are standard. ** Material not suitable for mineral oils. *** max. Ø 102 inches (2,600 mm)



■ Installation Recommendation (Inch Rod Series)

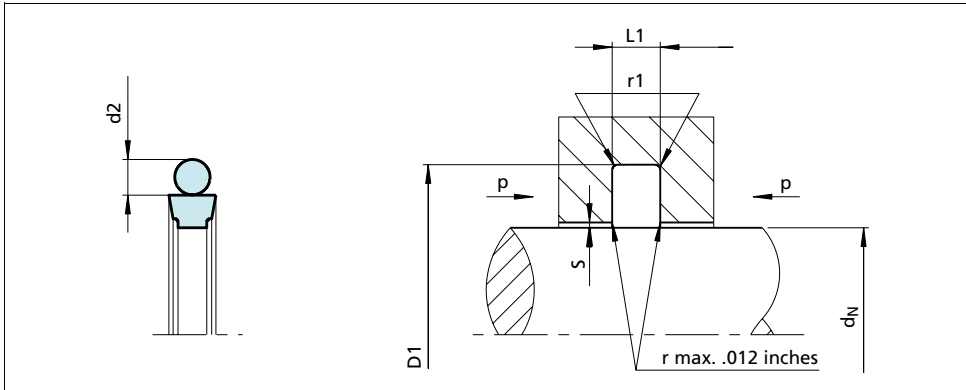

Figure 35 Installation drawing

Table XX Installation Recommendation

TSS Series No.	Rod Diameter d_N f8/h9			Groove Diameter* D_1 H9	Groove Width $L_1 +.008$	Radius r_1	Radial Clearance S max.**			O-Ring Cross-Section d_2
	Standard Application	Light Application	Heavy Duty Application				10 MPa 1500 psi	20 MPa 3000 psi	40 MPa 5800 psi	
RT10	-	.313 - .624	-	$d_N + .193$.087	.020	.020	.012	.008	.070
RT11	.313 - .624	.625 - 1.624	-	$d_N + .287$.126	.020	.024	.016	.008	.103
RT12	.625 - 1.624	1.625 - 3.249	.313 - .624	$d_N + .421$.165	.025	.024	.016	.008	.139
RT13	1.625 - 7.749	3.250 - 5.374	.625 - 1.624	$d_N + .594$.248	.030	.031	.020	.012	.210
RT14	7.750 - 9.999	5.375 - 12.999	1.625 - 3.249	$d_N + .807$.319	.035	.031	.020	.012	.275
RT15	10.000 - 20.000	13.000 - 26.000	3.250 - 5.375	$d_N + .945$.319	.035	.035	.020	.016	.275

* Installation with groove dimensions to ISO 7425/2 is possible.

** At pressures > 40 MPa (5,800 psi) use diameter tolerance H8/f8 (bore/rod) in area of the seal.



Ordering Example

Turcon® Glyd Ring® T, complete with O-Ring, standard application, Series RT14 (from Table XX)

Rod diameter: $d_N = 8.000$ inches
TSS Part No.: RT1408000 (from Table XXI)

Select the material from Table XIX. The corresponding code numbers are appended to the TSS Part No. (from Table XXI).

Together these form the TSS Article No. The TSS Article No. for all intermediate sizes not shown in Table XXI can be determined following the example below.

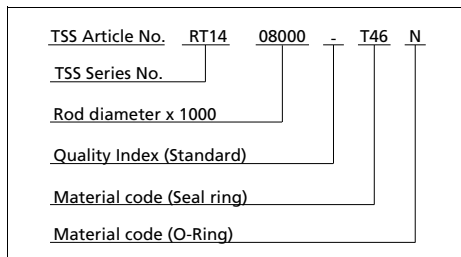

**** For diameters ≥ 20 inches please consult your Trelleborg Sealing Solutions sales office for special TSS Article No.

Table XXI Installation dimensions / TSS Part No

Rod Diameter	Groove Diameter	Groove Width	TSS Part No.
d_N f8/h9	D_1 H9	$L_1 +.008$	
.500	.693	.087	RT1000500
.563	.756	.087	RT1000563
.625	.912	.126	RT1100625
.688	.975	.126	RT1100688
.750	1.037	.126	RT1100750
.813	1.100	.126	RT1100813
.875	1.162	.126	RT1100875
.938	1.225	.126	RT1100938
1.000	1.287	.126	RT1101000
1.063	1.350	.126	RT1101063
1.125	1.412	.126	RT1101125
1.188	1.475	.126	RT1101188
1.250	1.537	.126	RT1101250
1.313	1.600	.126	RT1101313
1.375	1.662	.126	RT1101375
1.438	1.725	.126	RT1101438
1.500	1.787	.126	RT1101500
1.563	1.850	.126	RT1101563
1.625	2.046	.165	RT1201625
1.688	2.109	.165	RT1201688
1.750	2.171	.165	RT1201750

Rod Diameter	Groove Diameter	Groove Width	TSS Part No.
d_N f8/h9	D_1 H9	$L_1 +.008$	
1.813	2.234	.165	RT1201813
1.875	2.296	.165	RT1201875
1.938	2.359	.165	RT1201938
2.000	2.421	.165	RT1202000
2.125	2.546	.165	RT1202125
2.250	2.796	.165	RT1202250
2.375	2.796	.165	RT1202375
2.500	2.921	.165	RT1202500
2.625	3.046	.165	RT1202625
2.750	3.171	.165	RT1202750
2.875	3.296	.165	RT1202875
3.000	3.421	.165	RT1203000
3.125	3.546	.165	RT1203125
3.250	3.844	.248	RT1303250
3.375	3.969	.248	RT1303375
3.500	4.094	.248	RT1303500
3.625	4.219	.248	RT1303625
3.750	4.344	.248	RT1303750
3.875	4.469	.248	RT1303875
4.000	4.594	.248	RT1304000
4.125	4.719	.248	RT1304125



Turcon® Glyd Ring® T

Rod Diameter	Groove Diameter	Groove Width	TSS Part No.
d_N f8/h9	D_1 H9	L_1 +.008	
4.250	4.844	.248	RT1304250
4.375	4.969	.248	RT1304375
4.500	5.094	.248	RT1304500
4.625	5.219	.248	RT1304625
4.750	5.344	.248	RT1304750
4.875	5.469	.248	RT1304875
5.000	5.594	.248	RT1305000
5.125	5.719	.248	RT1305125
5.250	5.844	.248	RT1305250
5.375	6.182	.319	RT1405375
5.500	6.307	.319	RT1405500
5.625	6.432	.319	RT1405625
5.750	6.557	.319	RT1405750
6.000	6.807	.319	RT1406000
6.250	7.057	.319	RT1406250
6.500	7.307	.319	RT1406500
6.750	7.557	.319	RT1406750
7.000	7.807	.319	RT1407000
7.250	8.057	.319	RT1407250
7.500	8.307	.319	RT1407500
7.750	8.557	.319	RT1407750
8.000	8.807	.319	RT1408000
8.250	9.057	.319	RT1408250
8.500	9.307	.319	RT1408500
8.750	9.557	.319	RT1408750
9.000	9.807	.319	RT1409000
9.250	10.057	.319	RT1409250
9.500	10.307	.319	RT1409500
9.750	10.557	.319	RT1409750
10.000	10.807	.319	RT1410000
10.500	11.307	.319	RT1410500
11.000	11.807	.319	RT1411000
11.500	12.307	.319	RT1411500
12.000	12.945	.319	RT1512000
12.500	13.445	.319	RT1512500
13.000	13.945	.319	RT1513000

Rod Diameter	Groove Diameter	Groove Width	TSS Part No.
d_N f8/h9	D_1 H9	L_1 +.008	
13.500	14.445	.319	RT1513500
14.000	14.945	.319	RT1514000
14.500	15.445	.319	RT1514500
15.000	15.945	.319	RT1515000
15.500	16.445	.319	RT1515500
16.000	16.945	.319	RT1516000
16.500	17.445	.319	RT1516500
17.000	17.945	.319	RT1517000
17.500	18.445	.319	RT1517500
18.000	18.945	.319	RT1518000
18.500	19.445	.319	RT1518500
19.000	19.945	.319	RT1519000
19.500	20.445	.319	RT1519500
20.000	20.945	.319	RT1520000

The sizes listed in **bold** font are preferred sizes (more likely to be available for immediate shipment).

TURCON[®] GLYD RING[®]

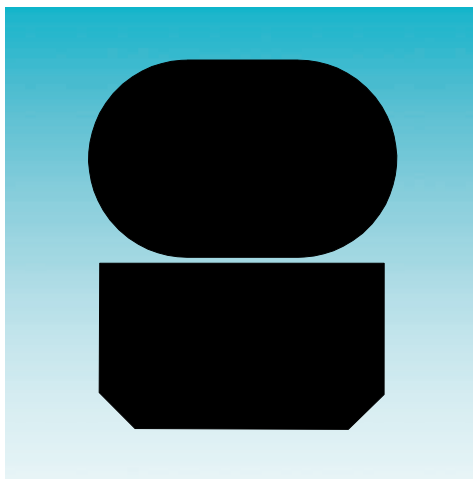

- Double-Acting -
- O-Ring-Energized Turcon[®] Slipper Seal -

- Material -
- Turcon[®] or Zurcon[®] -





■ Turcon® Glyd Ring®

Description

Successfully used for decades, the Turcon® Glyd Ring® is a very effective and reliable low friction seal. It is particularly suitable as a rod seal in both high and low pressure systems.

The double acting Turcon® Glyd Ring® is a combination of a Turcon® based slipper seal and an energizing O-Ring. It is produced with an interference fit which together with the squeeze of the O-Ring ensures a good sealing effect even at low pressure. At higher system pressures, the O-Ring is energized by the fluid, pushing the Turcon® Glyd Ring® against the sealing face with increased force.

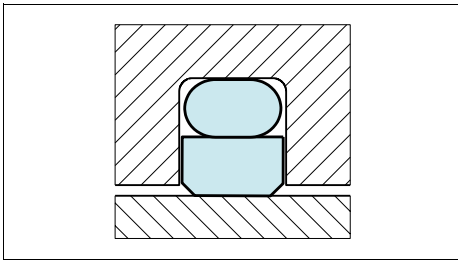

Figure 36 Turcon® Glyd Ring®

The geometry of the Turcon® Glyd Ring® ensures a good static sealing and allows the lubricating hydrodynamic oil film to build under the seal in reciprocating applications.

Notches

To assure that a rapid energizing of the seal takes place at sudden changes of pressure and direction of motion, the seal can be delivered with radial notches on both sides.

For ordering of Glyd Ring® with notches, see ordering example for this section.

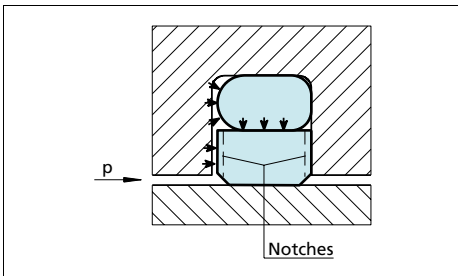

Figure 37 Turcon® Glyd Ring®

Advantages

- No stick-slip effect when starting for smooth operation
- Minimum static and dynamic friction coefficient for minimum energy loss and operating temperature
- Suitable for non lubricating fluids depending on seal material for optimum design flexibility
- High wear resistance ensures long service life
- No adhesive effect to the mating surface during long periods of inactivity or storage
- Suitable for most hydraulic fluids in relation to most modern hardware materials and surface finishes depending on material selected.
- Suitable for new environmentally safe hydraulic fluids
- Available for all rod diameters up to 102 inches (2,600 mm)

Applications examples

Over several decades the Turcon® Glyd Ring® has been successfully implemented in many applications as double or single-acting rod seals of hydraulic components such as:

- Injection molding machines
- Machine tools
- Presses
- Handling machinery
- Valves for hydraulic & pneumatic circuits



Technical Data

Operating conditions:

The Turcon® Glyd Ring® is recommended for reciprocating (with a length of stroke at least twice the groove width) and helical movements.

Pressure: Up to 11,600 psi (80 MPa)

Velocity: Up to 50 ft/s (15 m/s)

Frequency: Up to 5 Hz

Temperature: -49°F to +392°F (-45°C to +200°C)
(depending on O-Ring material)

Media: Mineral oil-based hydraulic fluids, barely flammable hydraulic fluids, environmentally safe hydraulic fluids (biological degradable oils), water, air and others, depending on the O-Ring material compatibility

Clearance: The maximum permissible radial clearance S_{max} is shown in the table XXIII, as a function of the operating pressure and functional diameter

Important Note:

The above data are maximum values and cannot be used at the same time. e.g. the maximum operating speed depends on material type, pressure, temperature and gap value. Temperature range also dependent on medium.

Materials

Standard Application:

For hydraulic components with reciprocating movement in mineral oils or medium with good lubricating performance

Turcon® seal: Turcon® T46

Energizer: O-Ring NBR 70 shore A or FKM 70 Shore A depending on the temperature

Set code: T46N or T46V

Special Application:

Short stroke movements, non-lubricating fluids or pneumatic applications require self-lubricating sealing materials. Therefore we recommend:

Turcon® Seal: Turcon® T29

Energizer: O-Ring NBR 70 Shore A or FKM 70 Shore A depending on the temperature

Set code: T29N or T29V

If low friction coefficient is required, we recommend:

Turcon® Seal: Turcon® T05

Energizer: O-Ring NBR 70 Shore A or FKM 70 Shore A depending on the temperature
For special requirements other elastomers are available on request

Set code: T05N or T05V

If rougher surface finish must be sealed, we recommend:

Zurcon® seal: Zurcon® Z51

Energizer: O-Ring NBR 70 Shore A

Set code: Z51N



Table XXII Turcon® and Zurcon® Materials for Glyd Ring®

Material, Applications, Properties	Code	O-Ring Material	Code	O-Ring Operating Temp.* °F	Mating Surface Material	PSI Max.
Turcon® T46 Standard material for hydraulics, high compressive strength, good sliding and wear properties, good extrusion resistance, BAM tested. Bronze filled Color: Grayish to dark brown	T46	NBR - 70 Shore A	N	-22 to +212	Steel, hardened Steel, chrome-plated Cast iron	8,700
		NBR - Low temp. 70 Shore A	T	-49 to +176		
		FKM - 70 Shore A	V	-14 to +392		
Turcon® T08 Very high compressive strength, very good extrusion resistance. High bronze filled Color: Light to dark brown	T08	NBR - 70 Shore A	N	-22 to +212	Steel, hardened Steel, chrome-plated Cast iron	11,600
		NBR - Low temp. 70 Shore A	T	-49 to +176		
		FKM - 70 Shore A	V	-14 to +392		
Turcon® T40 For all lubricating and non-lubricating hydraulic fluids, hydraulic oils without zinc, water hydraulic, soft mating surfaces. Surface texture not suitable for gases. Carbon fiber-filled Color: Gray	T40	NBR - 70 Shore A	N	-22 to +212	Steel Steel, chrome-plated Cast iron Stainless steel Aluminium Bronze Alloys	3,625
		NBR - Low temp. 70 Shore A	T	-49 to +176		
		FKM - 70 Shore A	V	-14 to +392		
		EPDM-70 Shore A	E**	-49 to +293		
Turcon® T29 For all lubricating and non-lubricating hydraulic fluids, hydraulic oils without zinc, soft mating surfaces, good extrusion resistance. Surface texture not suitable for gases. High carbon fiber-filled Color: Gray	T29	NBR - 70 Shore A	N	-22 to +212	Steel Steel, chrome-plated Cast iron Stainless steel Aluminium Bronze	8,700
		NBR - Low temp. 70 Shore A	T	-49 to +176		
		FKM - 70 Shore A	V	-14 to +392		
		EPDM-70 Shore A	E**	-49 to +293		
Turcon® T05 For all lubricating hydraulic fluids, hard mating surfaces, very good slide properties, low friction. Color: Turquoise	T05	NBR - 70 Shore A	N	-22 to +212	Steel, hardened Steel, chromeplated	2,900
		NBR - Low temp. 70 Shore A	T	-49 to +176		
		FKM - 70 Shore A	V	-14 to +392		
Turcon® T42 For all lubricating and non-lubricating hydraulic fluids, good chemical resistance, good dielectric properties. Glass fiber-filled + MoS ₂ Color: Gray to blue	T42	NBR - 70 Shore A	N	-22 to +212	Steel, hardened Steel, chrome-plated Cast iron	4,350
		NBR - Low temp. 70 Shore A	T	-49 to +176		
		FKM - 70 Shore A	V	-14 to +392		
Turcon® T10 For oil hydraulic and pneumatic, for all lubricating and non-lubricating fluids, high extrusion resistance, good chemical resistance, BAM tested. Carbon, graphite filled Color: Black	T10	NBR - 70 Shore A	N	-22 to +212	Steel Steel, chrome-plated Stainless steel	8,700
		NBR - Low temp. 70 Shore A	T	-49 to +176		
		FKM - 70 Shore A	V	-14 to +392		
		EPDM-70 Shore A	E**	-49 to +293		
Zurcon® Z51*** For lubricating hydraulic fluids, high abrasion resistance, high extrusion resistance, limited chemical resistance. Cast polyurethane Color: Yellow to light-brown	Z51	NBR - 70 Shore A	N	-22 to +212	Steel Steel, chrome-plated Cast iron Ceramic coating Stainless steel	11,600
		NBR - Low temp. 70 Shore A	T	-49 to +176		
Zurcon® Z80 For lubricating and non-lubricating hydraulic fluids, high abrasion resistance, very good chemical resistance, limited temperature resistance. Ultra high molecular weight polyethylene Color: White to off-white	Z80	NBR - 70 Shore A	N	-22 to +176	Steel Steel, chrome-plated Stainless steel Aluminium Bronze Ceramic coating	5,800
		NBR - Low temp. 70 Shore A	T	-49 to +176		

* The O-Ring Operation Temperature is only valid in mineral hydraulic oil. BAM: Tested by "Bundesanstalt Materialprüfung, Germany".
 Highlighted materials are standard. ** Material not suitable for mineral oils. *** max. Ø 102 inches (2200 mm)



■ Installation Recommendation (Inch Rod Series)

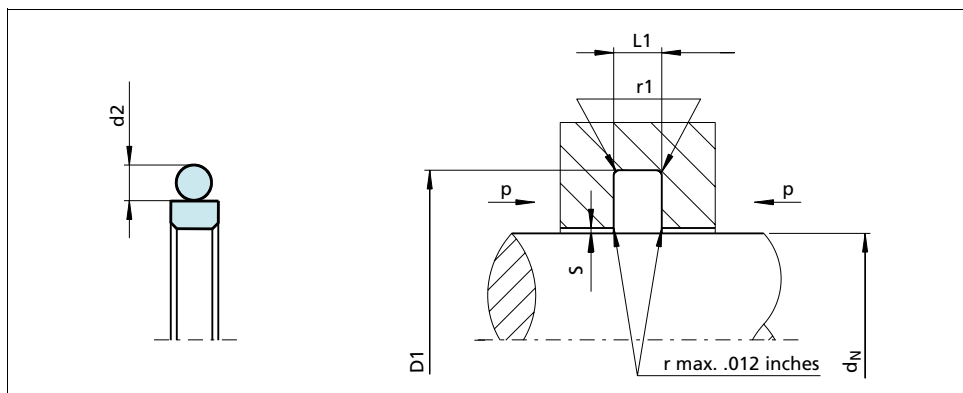

Figure 38 Installation drawing

Table XXIII Installation Recommendation

TSS Series No.	Rod Diameter			Groove Diameter*	Groove Width	Radius	Radial Clearance			O-Ring Cross-Section
	d _N f8/h9						S max.**			
	Standard Application	Light Application	Heavy Duty Application				D ₁ H9	L ₁ +.008	r ₁	
RG00	.313 - .624	.625 - 1.624	-	d _N + .193	.087	.015	.020	.012	.008	.070
RG01	.625 - 1.624	1.625 - 3.249	-	d _N + .287	.126	.025	.024	.016	.008	.103
RG02	1.625 - 3.249	3.250 - 5.374	.625 - 1.624	d _N + .421	.165	.025	.024	.016	.008	.139
RG03	3.250 - 5.374	5.375 - 12.999	1.625 - 3.249	d _N + .594	.248	.035	.031	.020	.012	.210
RG04	5.375 - 12.999	13.000 - 26.000	3.250 - 5.374	d _N + .807	.319	.035	.031	.020	.012	.275
RG05	13.000 - 26.000	-	5.375 - 13.000	d _N + .945	.319	.035	.035	.020	.016	.275

* Installation with groove dimensions to ISO 7425/2 is possible.

** At pressures > 40 MPa (5,800 psi) use diameter tolerance H8/f8 (bore/rod) in area of the seal or consult Trelleborg Sealing Solutions for alternative material or profiles.



Ordering example

Turcon® Glyd Ring®, complete with O-Ring, standard application, Series RG02 (from Table XXIII)

Rod diameter: $d_N = 1.625$ inches
 TSS Part No.: RG0201625 (from Table XXIV)

Select the material from Table XXII. The corresponding code numbers are appended to the TSS Part No. (from Table XXIV).

Together these form the TSS Article No. The TSS Article No. for all intermediate sizes not shown in Table XXIV can be determined following the example below.

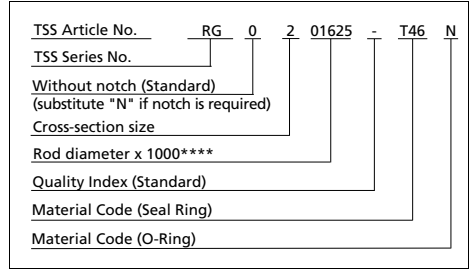

To order parts with notches substitute "N" for "0" in 3rd digit.

**** For diameters $d_N \geq 20$ inches please consult your Trelleborg Sealing Solutions sales office for special TSS Article No.

Table XXIV Installation dimensions / TSS Part No

Rod Diameter	Groove Diameter	Groove Width	TSS Part No.
d_N f8/h9	D_1 H9	L_1 +.008	
.500	.693	.087	RG0000500
.563	.756	.087	RG0000563
.625	.912	.126	RG0100625
.688	.975	.126	RG0100688
.750	1.037	.126	RG0100750
.813	1.100	.126	RG0100813
.875	1.162	.126	RG0100875
.938	1.225	.126	RG0100938
1.000	1.287	.126	RG0101000
1.063	1.350	.126	RG0101063
1.125	1.412	.126	RG0101125
1.188	1.475	.126	RG0101188
1.250	1.537	.126	RG0101250
1.313	1.600	.126	RG0101313
1.375	1.662	.126	RG0101375
1.438	1.725	.126	RG0101438
1.500	1.787	.126	RG0101500
1.563	1.850	.126	RG0101563
1.625	2.046	.165	RG0201625
1.688	2.109	.165	RG0201688
1.750	2.171	.165	RG0201750

Rod Diameter	Groove Diameter	Groove Width	TSS Part No.
d_N f8/h9	D_1 H9	L_1 +.008	
1.813	2.234	.165	RG0201813
1.875	2.296	.165	RG0201875
1.938	2.359	.165	RG0201938
2.000	2.421	.165	RG0202000
2.125	2.546	.165	RG0202125
2.250	2.796	.165	RG0202250
2.375	2.796	.165	RG0202375
2.500	2.921	.165	RG0202500
2.625	3.046	.165	RG0202625
2.750	3.171	.165	RG0202750
2.875	3.296	.165	RG0202875
3.000	3.421	.165	RG0203000
3.125	3.546	.165	RG0203125
3.250	3.844	.248	RG0303250
3.375	3.969	.248	RG0303375
3.500	4.094	.248	RG0303500
3.625	4.219	.248	RG0303625
3.750	4.344	.248	RG0303750
3.875	4.469	.248	RG0303875
4.000	4.594	.248	RG0304000
4.125	4.719	.248	RG0304125



Rod Diameter	Groove Diameter	Groove Width	TSS Part No.
d_N f8/h9	D_1 H9	L_1 +.008	
4.250	4.844	.248	RG0304250
4.375	4.969	.248	RG0304375
4.500	5.094	.248	RG0304500
4.625	5.219	.248	RG0304625
4.750	5.344	.248	RG0304750
4.875	5.469	.248	RG0304875
5.000	5.594	.248	RG0305000
5.125	5.719	.248	RG0305125
5.250	5.844	.248	RG0305250
5.375	6.182	.319	RG0405375
5.500	6.307	.319	RG0405500
5.625	6.432	.319	RG0405625
5.750	6.557	.319	RG0405750
6.000	6.807	.319	RG0406000
6.250	7.057	.319	RG0406250
6.500	7.307	.319	RG0406500
6.750	7.557	.319	RG0406750
7.000	7.807	.319	RG0407000
7.250	8.057	.319	RG0407250
7.500	8.307	.319	RG0407500
7.750	8.557	.319	RG0407750
8.000	8.807	.319	RG0408000
8.250	9.057	.319	RG0408250
8.500	9.307	.319	RG0408500
8.750	9.557	.319	RG0408750
9.000	9.807	.319	RG0409000
9.250	10.057	.319	RG0409250
9.500	10.307	.319	RG0409500
9.750	10.557	.319	RG0409750
10.000	10.807	.319	RG0410000
10.500	11.307	.319	RG0410500
11.000	11.807	.319	RG0411000
11.500	12.307	.319	RG0411500
12.000	12.945	.319	RG0512000
12.500	13.445	.319	RG0512500
13.000	13.945	.319	RG0513000

Rod Diameter	Groove Diameter	Groove Width	TSS Part No.
d_N f8/h9	D_1 H9	L_1 +.008	
13.500	14.445	.319	RG0513500
14.000	14.945	.319	RG0514000
14.500	15.445	.319	RG0514500
15.000	15.945	.319	RG0515000
15.500	16.445	.319	RG0515500
16.000	16.945	.319	RG0516000
16.500	17.445	.319	RG0516500
17.000	17.945	.319	RG0517000
17.500	18.445	.319	RG0517500
18.000	18.945	.319	RG0518000
18.500	19.445	.319	RG0518500
19.000	19.945	.319	RG0519000
19.500	20.445	.319	RG0519500
20.000	20.945	.319	RG0520000

The sizes listed in **bold** font are preferred sizes (more likely to be available for immediate shipment).

TURCON[®] GLYD RING[®] C

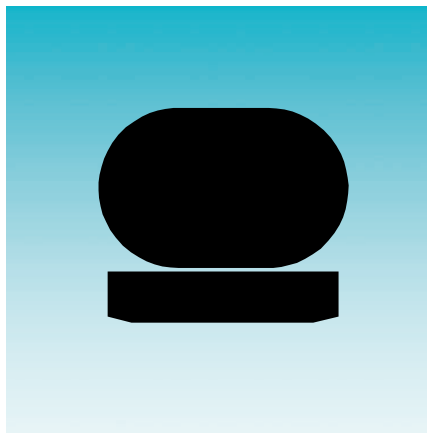

- Double-Acting -
- O-Ring-Energized Turcon[®] Slipper Seal -

- Material -
- Turcon[®] or Zurcon[®] -





■ Turcon® Glyd Ring® C

Description

The Turcon® Glyd Ring® C is a very effective and reliable low frictional seal. It is suitable as a double acting rod seal in both low and medium pressure systems.

The Turcon® Glyd Ring® C is a combination of a Turcon® based slipper seal and an energizing O-Ring. It is produced with an interference fit, which, together with the squeeze of the O-Ring, ensures a good sealing effect even at low pressure. At higher system pressures, the O-Ring is energized by the fluid, pushing the Turcon® Glyd Ring® C against the sealing face with increased force.

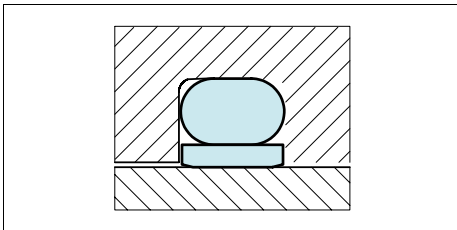

Figure 39 Turcon® Glyd Ring® C

The geometry of the Turcon® Glyd Ring® C ensures an effective static sealing and allows the lubricating hydrodynamic fluid film to be build under the seal in reciprocating applications.

Notches

To assure that a rapid energizing of the seal takes place at sudden changes of pressure and direction of motion, the seal can be delivered with radial "notches" on both sides.

Ordering of Glyd Ring® C with "notches" see page 75.

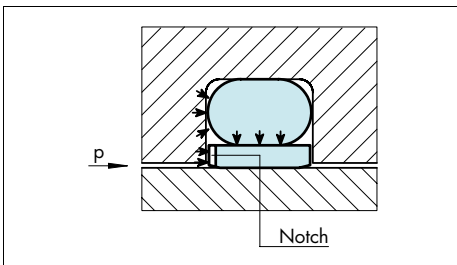

Figure 40 Turcon® Glyd Ring® C with notches on both sides

Advantages

- No stick-slip effect when starting for smooth operation
- Minimum static and dynamic friction coefficient for a minimum energy loss and operating temperature
- Suitable for non lubricating fluids depending on seal material for optimum design flexibility
- High wear resistance ensures long service life
- No adhesive effect to the mating surface during long period of inactivity or storage
- Suitable for most hydraulic fluids in relation with most modern hardware materials and surface finish depending on material selected
- Suitable for new environmentally safe hydraulic fluids

Applications examples

Over several decades the Turcon® Glyd Ring® C has been successfully implemented in a lot of applications as double acting Rod seals of hydraulic components such as:

- Machine tools
- Robotics
- Handling machinery
- Manipulators
- Valves for hydraulic & pneumatic circuits
- Fittings
- Testing machinery
- Hydraulic power steering
- Brake systems
- Brake boosters
- Low temperature hydraulics
- Chemical processing equipment
- Filling machines



Technical Data

Operating conditions:

The Turcon® Glyd Ring® C is recommended for reciprocating movements (with a length of stroke at least twice the groove width).

Pressure: Up to 5,800 psi (40MPa)

Velocity: Up to 50 ft/s (15m/s)

Frequency: Up to 5 Hz.

Temperature: -49°F to +392°F (-45°C to +200°C)
(depending on O-Ring Material)

Media: Mineral oil based hydraulic fluids,
barely flammable hydraulic fluids,
environmentally safe hydraulic fluids
(biological degradable oils),
water, air and others.
Depending on the O-Ring material
compatibility

Clearance: The maximum permissible radial clearance
S max is shown in the table XXVI, as a
function of the operating pressure and
functional diameter.

Important Note:

The above data are maximum values and cannot be used at the same time. e.g. the maximum operating speed depends on material type, pressure, temperature and gap value. Temperature range also dependent on medium.

Materials

Standard Application:

For hydraulic components with reciprocating movement in mineral oils or medium with good lubricating performance.

Seal Ring: Turcon® T46

Energizer: O-Ring NBR 70 shore A or FKM 70
Shore A depending on the
temperature

Set code: T46N or T46V

Special Application:

- For short stroke movements, non-lubricating fluids or applications requiring self-lubricating sealing materials we recommend:

Seal Ring: Turcon® T40

Energizer: O-Ring NBR 70 Shore A or FKM 70
Shore A depending on the temperature

Set code: T40N or T40V

- If very low friction coefficient is required, we recommend:

Seal Ring: Turcon® T05

Energizer: O-Ring NBR 70 Shore A or FKM 70
Shore A depending on the temperature
For special requirements other
elastomers are available on request

Set code: T05N or T05V

- If rougher surface finish must be sealed, we recommend:

Seal Ring: Zurcon® Z51

Energizer: O-Ring NBR 70 Shore A

Set code: Z51N

- If exposure to water is required, we recommend:

Seal Ring: Zurcon® Z80

Energizer: O-Ring NBR 70 Shore A

Set code: Z80N



Table XXV Turcon® Glyd Ring® C

Material, Applications, Properties	Code	O-Ring Material	Code	O-Ring Operating Temp.* °F	Mating Surface Material	PSI Max.
Turcon® T46 Standard material for hydraulics, high compressive strength, good sliding and wear properties, good extrusion resistance, BAM tested. Bronze filled Color: Grayish to dark brown	T46	NBR-70 Shore A	N	-22 to +212	Steel, hardened Steel, chrome-plated Cast iron	5,800
		NBR-Low temp. 70 Shore A	T	-49 to +176		
		FKM-70 Shore A	V	-14 to +392		
Turcon® T24 For all lubricating and non-lubricating hydraulic fluids, soft mating surfaces. Carbon filled Color: Black	T24	NBR-70 Shore A	N	-22 to +212	Steel Steel, hardened Cast iron Stainless steel Aluminium Bronze	3,625
		NBR-Low temp. 70 Shore A	T	-49 to +176		
		FKM-70 Shore A	V	-14 to +392		
		EPDM - 70 Shore A	E**	-49 to +293		
Turcon® T05 For all lubricating hydraulic fluids, hard mating surfaces, very good sliding properties, low friction. Color: Turquoise	T05	NBR-70 Shore A	N	-22 to +212	Steel tubes Steel, hardened	2,900
		NBR-Low temp. 70 Shore A	T	-49 to +176		
		FKM-70 Shore A	V	-14 to +392		
Turcon® T40 For all lubricating and non-lubricating hydraulic fluids, water hydraulic, soft mating surfaces. Surface texture not suitable for gases. Carbon fiber filled Color: Gray	T40	NBR-70 Shore A	N	-22 to +212	Steel Cast iron Stainless steel Aluminium Bronze Alloys	3,625
		NBR-Low temp. 70 Shore A	T	-49 to +176		
		FKM-70 Shore A	V	-14 to +392		
		EPDM-70 Shore A	E**	-49 to +293		
Zurcon® Z51 For lubricating hydraulic fluids, high abrasion resistance, high extrusion resistance, limited chemical resistance. Cast polyurethane Color: Yellow to light-brown	Z51	NBR-70 Shore A	N	-22 to +212	Steel Steel, hardened Cast iron Ceramic coating Stainless steel	5,800
		NBR-Low temp. 70 Shore A	T	-49 to +176		
Zurcon® Z80 For lubricating and non-lubricating hydraulic fluids, high abrasion resistance, very good chemical resistance, limited temp. resistance. Ultra high molecular weight polyethylene Color: White to off-white	Z80	NBR-70 Shore A	N	-22 to +176	Steel Stainless steel Aluminium Bronze Ceramic coating	5,800
		NBR-Low temp. 70 Shore A	T	-49 to +176		

* The O-Ring Operation Temperature is only valid in mineral hydraulic oil. BAM: Tested by "Bundesanstalt Materialprüfung, Germany".
 □ Highlighted materials are standard. ** Material not suitable for mineral oils.



■ Installation Recommendation (Inch Rod Series)

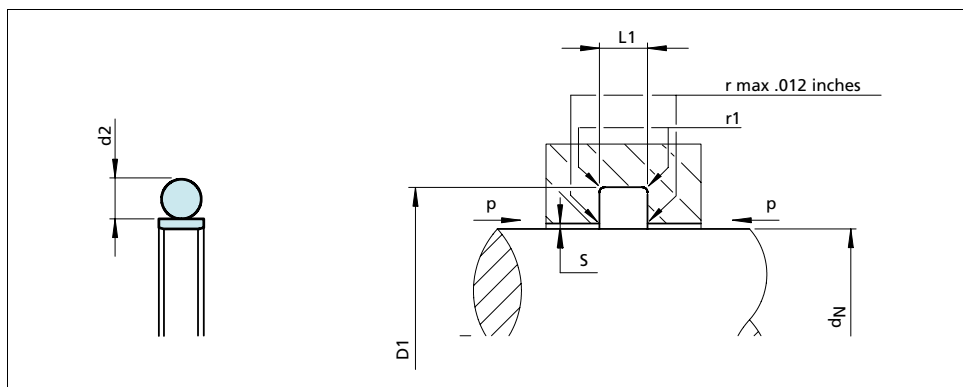

Figure 41 Installation drawing

Table XXVI Installation Recommendation

Dash No.	Rod Diameter d_N f8/h9		Groove Diameter D_1 H9	Groove Width $L_1 +.008$	Radius r_1	Radial Clearance S max. 20 MPa 3000 psi
	Standard Application	Light Application				
006-009	.125 - .219	-	$d_N + .143$.079	.020	.0020
010-027	.250 - .312	.375 - 1.312	$d_N + .172$.079	.020	.0020
110-148	.375 - .687	.750 - 2.750	$d_N + .236$.112	.020	.0025
210-221	.750 - 1.437	-	$d_N + .300$.149	.030	.0030
222-247	-	1.500 - 4.625	$d_N + .363$.149	.030	.0030
325-348	1.500 - 4.375	-	$d_N + .491$.221	.050	.0035
425-436	4.500 - 5.875	-	$d_N + .593$.297	.060	.0040
437-444	6.000 - 7.750	-	$d_N + .718$.297	.060	.0040
445-459	8.000 - 15.000	-	$d_N + .968$.297	.060	.0040



Ordering Example

Turcon® Glyd Ring® C, complete with O-Ring, standard application, Series RG46 (from Table XXVI)

Dash No.: 231

TSS Article No.: RG460B231 (from Table XXVII)

The corresponding code numbers are appended to the TSS Part No. (from Table XXVII). Together they form the TSS Article No.

All intermediate sizes not shown in Table XXVII will have special TSS Article No.

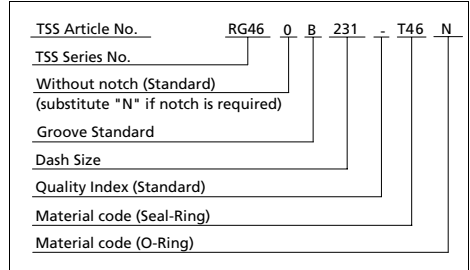

Note:

Dash sizes represent rod sizes and groove dimensions are per TSS specifications

Table XXVII Installation dimensions / TSS Part No

Rod Diameter	Groove Diameter	Groove Width	TSS Part No.
d_N f8/h9	D_1 H9	L_1 +.008	
.250	.422	.079	RG460B010
.313	.485	.079	RG460B011
.375	.547	.079	RG460B012
.438	.610	.079	RG460B013
.500	.672	.079	RG460B014
.563	.735	.079	RG460B015
.625	.797	.079	RG460B016
.688	.860	.079	RG460B017
.750	.922	.079	RG460B018
.813	.985	.079	RG460B019
.875	1.047	.079	RG460B020
.938	1.110	.079	RG460B021
1.000	1.236	.112	RG460B120
1.063	1.299	.112	RG460B121
1.125	1.361	.112	RG460B122
1.188	1.424	.112	RG460B123
1.250	1.486	.112	RG460B124
1.313	1.549	.112	RG460B125
1.375	1.611	.112	RG460B126
1.438	1.674	.112	RG460B127
1.500	1.736	.112	RG460B128

The sizes listed in **bold** font are preferred sizes (more likely to be available for immediate shipment).



Turcon® Glyd Ring® C

Rod Diameter	Groove Diameter	Groove Width	TSS Part No.
d_N f8/h9	D_1 H9	L_1 +.008	
1.563	1.799	.112	RG460B129
1.625	1.861	.112	RG460B130
1.688	1.924	.112	RG460B131
1.750	1.986	.112	RG460B132
1.813	2.049	.112	RG460B133
1.875	2.111	.112	RG460B134
1.938	2.174	.112	RG460B135
2.000	2.236	.112	RG460B136
2.063	2.299	.112	RG460B137
2.125	2.361	.112	RG460B138
2.188	2.424	.112	RG460B139
2.250	2.486	.112	RG460B140
2.313	2.549	.112	RG460B141
2.375	2.611	.112	RG460B142
2.438	2.674	.112	RG460B143
2.500	2.736	.112	RG460B144
2.625	2.988	.149	RG460B231
2.750	3.113	.149	RG460B232
2.875	3.238	.149	RG460B233
3.000	3.363	.149	RG460B234
3.125	3.488	.149	RG460B235
3.250	3.613	.149	RG460B236
3.375	3.738	.149	RG460B237
3.500	3.991	.221	RG460B341
3.625	4.116	.221	RG460B342
3.750	4.241	.221	RG460B343
3.875	4.366	.221	RG460B344
4.000	4.491	.221	RG460B345
4.125	4.616	.221	RG460B346
4.250	4.741	.221	RG460B347
4.375	4.866	.221	RG460B348
4.500	5.093	.297	RG460B425
4.625	5.218	.297	RG460B426
4.750	5.343	.297	RG460B427
4.875	5.468	.297	RG460B428
5.000	5.593	.297	RG460B429

The sizes listed in **bold** font are preferred sizes (more likely to be available for immediate shipment).



Rod Diameter	Groove Diameter	Groove Width	TSS Part No.
d_N f8/h9	D_1 H9	L_1 +.008	
5.125	5.718	.297	RG460B430
5.250	5.843	.297	RG460B431
5.375	5.968	.297	RG460B432
5.500	6.093	.297	RG460B433
5.625	6.218	.297	RG460B434
5.750	6.343	.297	RG460B435
5.875	6.468	.297	RG460B436
6.000	6.718	.297	RG460B437
6.250	6.968	.297	RG460B438
6.500	7.218	.297	RG460B439
6.750	7.468	.297	RG460B440
7.000	7.718	.297	RG460B441
7.250	7.968	.297	RG460B442
7.500	8.218	.297	RG460B443
7.750	8.468	.297	RG460B444
8.000	8.968	.297	RG460B445
8.500	9.468	.297	RG460B446
9.000	9.968	.297	RG460B447
9.500	10.468	.297	RG460B448
10.000	10.968	.297	RG460B449
10.500	11.468	.297	RG460B450
11.000	11.968	.297	RG460B451
11.500	12.468	.297	RG460B452
12.000	12.968	.297	RG460B453

The sizes listed in **bold** font are preferred sizes (more likely to be available for immediate shipment).



Turcon[®] Glyd Ring[®] C

TURCON[®] VL SEAL[®]

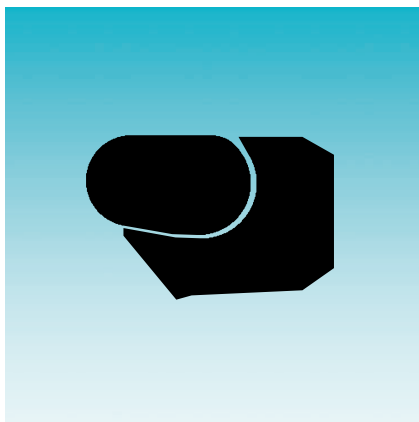

- Single-Acting -
- O-Ring-Energized Turcon[®] Slipper Seal -

- Material -
- Turcon[®] or Zurcon[®] -





■ Turcon® VL Seal®*

Description

The Turcon® VL Seal® incorporates theoretical and empirical experience in a new generation seal for the 21st century.

The VL Seal® has been developed over the past few years as a new generation unidirectional Rod seal. The design has taken the latest empirical and theoretical experience into account in order to optimize performance, friction, leakage and service life. This has been achieved through in-house testing and qualified in customer applications. See test section.

The back-pumping effect allows the seal to relieve pressure trapped between tandem seals or between seals and double-acting scrapers.

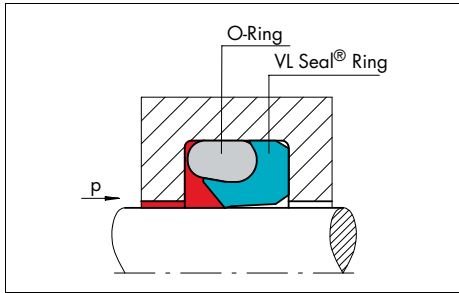

Figure 42 Turcon® VL Seal®

Method of Operation

The sealing mechanism of the Turcon® VL Seal® (Figure 42) is based on the hydrodynamic properties of the seal. The specially formed seal edge has a steep contact pressure gradient on the high pressure side and a shallow contact pressure gradient on the low pressure side. This ensures that the fluid film adhering to the piston rod is returned to the high pressure chamber on the return stroke of the rod. This prevents the micro-fluid layer, that is carried out of the high pressure chamber when the piston rod is extended, from causing leaks.

This return delivery property prevents the build-up of interstage pressure normally associated with tandem seal configurations (Figure 43). Interstage pressure depends on the system pressure speed, the stroke length and the groove design.

* Patent pending. (US Patent No. 6,497,415)

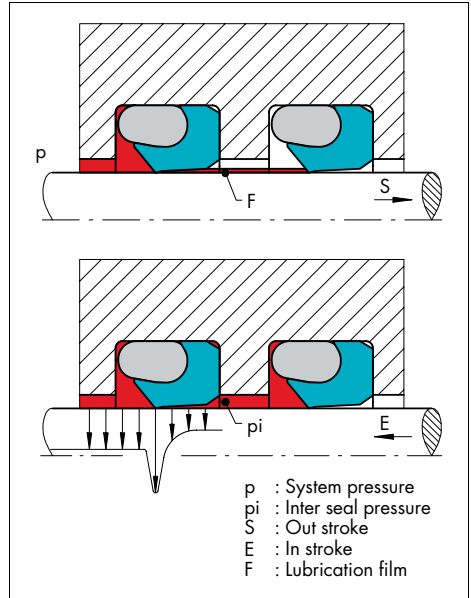

Figure 43 Pressure Distribution in Tandem Installation

Advantages

Compared with current rod seals, the following parameters have been improved:

- VL Seal® design allows gland for a reduced radial depth
- Tighter leakage control
- Lower friction: (Reduced contact area between seal and mating surface)
- Simplicity of design, using standard size O-Ring
- Featuring the Turcon® Stepseal® 2K back pumping effect
- The seal geometry prevents seal roll at low or shuffling pressure



Technical Data

Operating pressure: 5,000 psi (35 MPa)

Velocity: Up to 50 ft/s (15 m/s) with reciprocating movements

Temperature range: -65°F to +390°F (-54°C to +200°C) depending on elastomer material

Clearance: As per Table XXIX

Media: Mineral oil-based hydraulic fluids, flame retardant hydraulic fluids, environmentally safe hydraulic fluids (bio-oils), Phosphate Ester, water and others, depending on the elastomer material

Important Note:

The above data are maximum values and cannot be used at the same time. e.g. the maximum operating speed depends on material type, pressure, temperature and gap value. Temperature range also dependent on medium.

Table XXVIII Turcon® and Zurcon® Materials for Turcon® VL Seal®

Material, Applications, Properties	Code	O-Ring Material	Code	O-Ring Operating Temp.* °F	Mating Surface Material	PSI Max.
Turcon® T46 Standard material for hydraulics, high compressive strength, good sliding and wear properties, good extrusion resistance, BAM tested. Bronze filled Color: Grayish to dark brown	T46	NBR-70 Shore A	N	-22 to +212	Steel, hardened Steel, chrome-plated Cast iron	10,152
		NBR-Low temp. 70 Shore A	T	-49 to +176		
		FKM-70 Shore A	V	-14 to +392		
Turcon® T29 For all lubricating and non-lubricating hydraulic fluids, hydraulic oils without zinc, soft mating surfaces, good extrusion resistance. Surface texture not suitable for gases. High carbon fiber filled Color: Gray	T29	NBR-70 Shore A	N	-22 to +212	Steel Steel, chrome-plated Cast iron Stainless steel Aluminium Bronze	10,152
		NBR-Low temp. 70 Shore A	T	-49 to +176		
		FKM-70 Shore A	V	-14 to +392		
		EPDM-70 Shore A	E**	-49 to +293		
Turcon® T05 For all lubricating hydraulic fluids, hard mating surfaces, very good slide properties, low friction. Color: Turquoise	T05	NBR-70 Shore A	N	-22 to +212	Steel, hardened Steel, chrome-plated	3,625
		NBR-Low temp. 70 Shore A	T	-49 to +176		
		FKM-70 Shore A	V	-14 to +392		
Zurcon® Z51*** For lubricating hydraulic fluids, high abrasion resistance, high extrusion resistance, limited chemical resistance. Cast polyurethane Color: Yellow to light-brown	Z51	NBR-70 Shore A	N	-22 to +212	Steel Steel, chrome-plated Cast iron Ceramic coating Stainless steel	11,603
		NBR-Low temp. 70 Shore A	T	-49 to +176		





■ Installation Recommendation (Inch Rod Series)

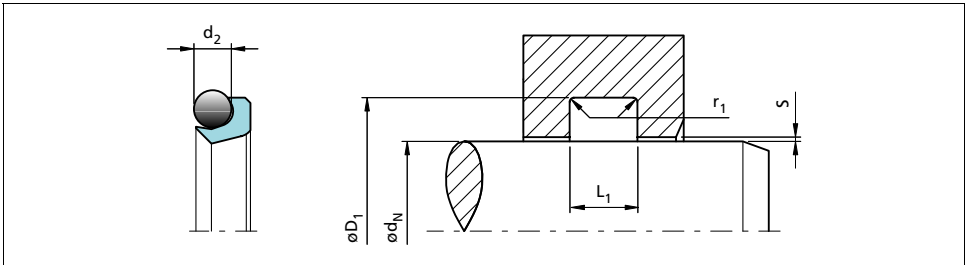

Figure 44 Installation drawing

Table XXIX Installation Recommendation

Rod Diameter d_N f8/h9				Groove Diameter D_1 H9	Groove Width $L_1 + .008$	Radius r_1	Radial Clearance S max.			O-ring Cross-Section d_2
TSS Series No.	Standard Application	Light Application	Heavy Duty Application				10 MPa 1500 psi	20 MPa 3000 psi	40 MPa 5800 psi	
REL1	.375 - .749	.750 - 4.000	.250 - .374	$d_N + .177$.142	.160	.016	.010	.006	.070
REL2	.750 - 1.499	1.500 - 8.000	.438 - .749	$d_N + .244$.189	.240	.016	.010	.008	.103
REL3	1.500 - 4.749	4.750 - 16.000	.750 - 1.499	$d_N + .370$.280	.320	.020	.012	.008	.139
REL4	4.750 - 15.999	16.000 - 25.000	1.375 - 4.749	$d_N + .480$.374	.320	.024	.014	.010	.210
REL5	16.000 - 40.000	-	5.000 - 15.999	$d_N + .626$.480	.320	.028	.020	.012	.275

The seal is designed for MIL-G5514F/AS4716 groove geometries, but higher clearances can be accommodated according to service conditions.

The seal is designed for 0 back-up ring groove width, but installation may be facilitated by the use of a 1 back-up ring groove width and filling the groove with a back-up ring, as a spacer.

Seals for 1 & 2 back-up ring groove widths can be used with solid b/u-rings (a scarfcut is only recommended for small diameters < 25 mm / 1 inch) to ease installation. Special back-up rings can be designed and supplied for unique application requirements.

The standard range can be installed in closed groove down to .800 inches / 20 mm, 0 back-up ring. Smaller diameters down to .630 inches / 16 mm can be installed for 1 or 2 back-up ring groove width. Back-up ring to be installed afterwards.



Turcon® VL Seal®

Ordering Example

VL Seal® rod, metric part no.

TSS Series No: REL 3
 Rod diameter: 2.000 inches (50.8 mm)
 Material: Turcon® T46

TSS Article No.	REL3	00508	-	T46	N
TSS Series No.					
Rod diameter x 10					
Quality Index (Standard)					
Material code (Seal Ring)					
Material code (O-Ring)					

Table XXX Installation dimensions / TSS Part No

Rod Diameter d _N f8/h9	Groove Diameter D ₁ H9	Groove Width L ₁ +.008	TSS Part No.
.500	.677	.142	REL100127
.563	.740	.142	REL100143
.625	.802	.142	REL100159
.688	.865	.142	REL100175
.750	.927	.142	REL100191
.813	1.057	.189	REL200206
.875	1.119	.189	REL200222
.938	1.182	.189	REL200238
1.000	1.244	.189	REL200254
1.063	1.307	.189	REL200270
1.125	1.369	.189	REL200286
1.188	1.432	.189	REL200302
1.250	1.494	.189	REL200318
1.313	1.557	.189	REL200333
1.375	1.619	.189	REL200349
1.438	1.682	.189	REL200365
1.500	1.744	.189	REL200381
1.563	1.807	.189	REL200397
1.625	1.995	.280	REL300413
1.688	2.058	.280	REL300429
1.750	2.120	.280	REL300445

Rod Diameter d _N f8/h9	Groove Diameter D ₁ H9	Groove Width L ₁ +.008	TSS Part No.
1.813	2.183	.280	REL300460
1.875	2.245	.280	REL300476
1.938	2.308	.280	REL300492
2.000	2.370	.280	REL300508
2.125	2.495	.280	REL300540
2.250	2.620	.280	REL300572
2.375	2.745	.280	REL300603
2.500	2.870	.280	REL300635
2.625	2.995	.280	REL300667
2.750	3.120	.280	REL300699
2.875	3.245	.280	REL300730
3.000	3.370	.280	REL300762
3.125	3.495	.280	REL300794
3.250	3.620	.280	REL300826
3.375	3.745	.280	REL300857
3.500	3.870	.280	REL300889
3.625	3.995	.280	REL300921
3.750	4.120	.280	REL300953
3.875	4.245	.280	REL300984
4.000	4.370	.280	REL301016
4.125	4.495	.280	REL301048



Rod Diameter d _N f8/h9	Groove Diameter D ₁ H9	Groove Width L ₁ +.008	TSS Part No.
4.250	4.620	.280	REL301080
4.375	4.745	.280	REL301111
4.500	4.870	.280	REL301143
4.625	4.995	.280	REL301175
4.750	5.230	.374	REL401207
4.875	5.355	.374	REL401238
5.000	5.480	.374	REL401270
5.125	5.605	.374	REL401302
5.250	5.730	.374	REL401334
5.375	5.855	.374	REL401365
5.500	5.980	.374	REL401397
5.625	6.105	.374	REL401429
5.750	6.230	.374	REL401461
6.000	6.480	.374	REL401524
6.250	6.730	.374	REL401588
6.500	6.980	.374	REL401651
6.750	7.230	.374	REL401715
7.000	7.480	.374	REL401778
7.250	7.730	.374	REL401842
7.500	7.980	.374	REL401905
7.750	8.230	.374	REL401969
8.000	8.480	.374	REL402032
8.250	8.730	.374	REL402096
8.500	8.980	.374	REL402159
8.750	9.230	.374	REL402223
9.000	9.480	.374	REL402286
9.250	9.730	.374	REL402350
9.500	9.980	.374	REL402413
9.750	10.230	.374	REL402477
10.000	10.480	.374	REL402540

The sizes listed in **bold** font are preferred sizes (more likely to be available for immediate shipment).



TURCON[®] VARISEAL[®] M2

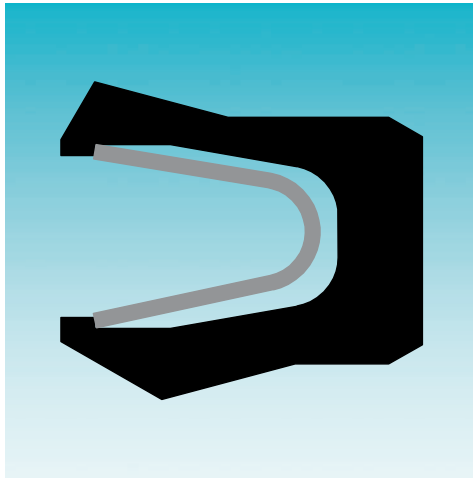

- Single-Acting -
- Spring-Energized Turcon[®] U-Cup -

- Material -
- Turcon[®] or Zurcon[®] -





■ Turcon® Variseal® M2

Description

The Turcon® Variseal® M2 is a single-acting seal consisting of a U-shaped seal jacket and a V-shaped corrosion-resistant spring.

Variseal® M2 has an asymmetric seal profile. The heavy profile of its dynamic lip with an optimized front angle offers good leakage control, reduced friction and long service life.

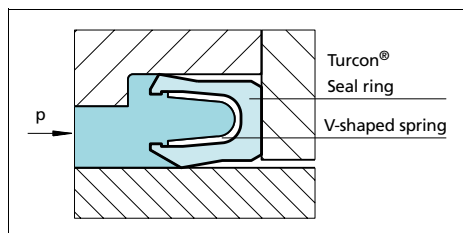

Figure 45 Turcon® Variseal® M2

At low and zero pressure, the metal spring provides the primary sealing force. As the system pressure increases, the main sealing force is achieved by the system pressure and ensures a tight seal from zero to high pressure.

The possibility of matching suitable materials for the seal and the spring allows use in a wide range of applications going beyond the field of hydraulics, e.g. in the chemical, pharmaceutical and foodstuff industries.

The Variseal® M2 can be sterilized and is available in a special Hi-Clean version where the spring cavity is filled with a silicone gel preventing contaminants from being entrapped in the seal. This design also works well in applications involving mud, slurries or adhesives to keep grit from packing into the seal cavity and inhibiting the spring action.

For applications with highly viscous media, please contact our engineering department.

Variseal® M2 seals can be installed in grooves to AS4716 and ISO 3771. The seal can only be installed to a limited extent in closed grooves, for installation instructions, see fig. 14.

Advantages

- Resistant to most fluids and chemicals
- Low coefficients of friction
- Stick-slip-free operating for precise control
- High abrasion resistance and dimensional stability

- Can handle rapid changes in temperature
- No contamination in contact with foodstuffs, pharmaceutical and medicinal fluids
- High temperature range
- Sterilizable
- Unlimited shelf life

Application Examples

Turcon® Variseal® M2 is the recommended sealing element for all applications requiring stick slip free operation as well as chemical resistance against almost all media such as:

- Valves
- Pumps
- Separators
- Actuators
- Dosing devices

It requires a mating surface of high quality to avoid high wear rate.

Technical Data

Operating conditions

Pressure: For static loads: 5,800 psi (40 MPa)
For dynamic loads: 2,900 psi (20 MPa)

Velocity: Reciprocating: Up to 50 ft/s (15 m/s)
Rotating: Up to 3.3 ft/s (1 m/s)

Temperature: -94°F to +500°F (-70°C to +260°C)

For specific applications beyond indicated range, please inquire

Media: Virtually all fluids, chemicals and gases

Important Note:

The above data are maximum values, when using standard materials and geometries, and cannot be used at the same time. e.g. the maximum operating speed depends on material type, pressure, temperature and gap value. Temperature range also dependent on medium.



Turcon® Variseal® M2

Materials

All materials used are physiologically safe. They contain no odor or taste-affecting substances.

The following material combination has proven effective for most fluid applications:

Seal ring: Turcon® T40

Spring: Stainless Steel Material No. AISI 301
Code S

For gas application use:

Seal ring: Turcon® T05/Zurcon® Z80

For use in accordance with the demands of the "Food and Drug Administration," suitable materials are available on request.

Table XXXI Turcon® and Zurcon® Materials for Variseal® M2

Material, Applications, Properties	Code	Spring Material	Code	Operating Temp. * °F	Mating Surface Material	PSI Max.
Turcon® T40 For all lubricating and non-lubricating hydraulic fluids, hydraulic oils without zinc, water hydraulic, hard mating surfaces. Surface texture not suitable for gases. Carbon fiber-filled Color: Gray	T40	AISI 301	S	-94 to +500	Steel, hardened Steel, chrome-plated	5,800
Turcon® T05 For all lubricating hydraulic fluids, soft mating surfaces, very good sliding properties, low friction. Color: Turquoise	T05	AISI 301	S	-94 to +500	Steel Steel, chrome-plated Cast iron Stainless steel Aluminium Bronze Alloys	2,900
Zurcon® Z80 For lubricating and non-lubricating hydraulic fluids, high abrasion resistance, very good chemical resistance, limited temperature resistance. Ultra high molecular weight polyethylene Color: White to off-white	Z80	AISI 301	S	-94 to +176	Steel Steel, chrome-plated Stainless steel Aluminium Bronze Ceramic coating	5,800
Zurcon® Z48 For tight sealing with long wear life, in applications without high temperatures or corrosive chemicals. Color: Black	Z48	AISI 301	S	-76 to +266	Steel Steel, chrome-plated Cast iron Stainless steel Aluminium Bronze Alloys Ceramic coating	5,800

* Depending on media. Highlighted material is standard.



■ Installation Recommendation (Inch Rod Series)

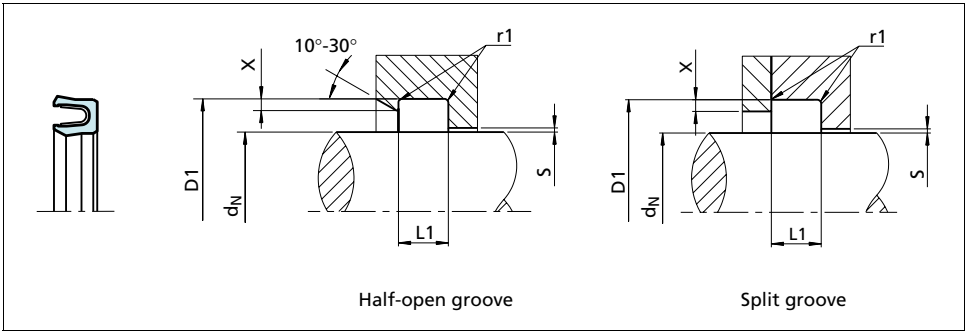

Figure 46 Installation drawing

Table XXXII Installation Recommendation

TSS Series No. for Types	Cross-section	Groove Width	Radius	Radial Clearance S max.*			
				300 psi	1500 psi	3000 psi	5000 psi
Variseal® M2	D ₁ - d _n (Ref)	L ₁ +.010	r ₁				
RVAA	.062	.094	.010	.008	.004	.003	.002
RVAB	.093	.141	.015	.010	.006	.004	.003
RVAC	.125	.188	.015	.014	.008	.006	.003
RVAD	.187	.281	.015	.020	.010	.008	.004
RVAE	.250	.375	.020	.024	.012	.010	.005
RCAF	.375	.591	.020	.030	.015	.012	.006

* At pressures > 40 MPa (5,800 psi): use diameter tolerance H8/f8 (bore/rod) in area of the seal.

Ordering Example

Turcon® Variseal® M2, recommended range, Series RVAC (from Table XXXII).

Dash No. 230

TSS Part No.: RVACNB230 (from Table XXXIII)

For other seal and spring materials please contact your local Trelleborg Sealing Solutions sales office.

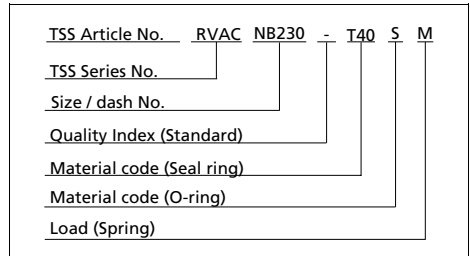



Table XXXIII Installation dimensions / TSS Part No

Rod Diameter	Groove Diameter	Groove Width	TSS Part No.
d_{Nh9}	D_{1H9}	$L_{1+.010}$	
.250	.437	.141	RVABNB108
.313	.500	.141	RVABNB109
.375	.562	.141	RVABNB110
.438	.625	.141	RVABNB111
.500	.687	.141	RVABNB112
.563	.750	.141	RVABNB113
.625	.875	.188	RVACNB208
.688	.938	.188	RVACNB209
.750	1.000	.188	RVACNB210
.813	1.063	.188	RVACNB211
.875	1.125	.188	RVACNB212
.938	1.188	.188	RVACNB213
1.000	1.250	.188	RVACNB214
1.063	1.313	.188	RVACNB215
1.125	1.375	.188	RVACNB216
1.188	1.438	.188	RVACNB217
1.250	1.500	.188	RVACNB218
1.313	1.563	.188	RVACNB219
1.375	1.625	.188	RVACNB220
1.438	1.688	.188	RVACNB221
1.500	1.875	.281	RVADNB325
1.625	2.000	.281	RVADNB326
1.750	2.125	.281	RVADNB327
1.875	2.250	.281	RVADNB328
2.000	2.375	.281	RVADNB329
2.125	2.500	.281	RVADNB330
2.250	2.625	.281	RVADNB331
2.375	2.750	.281	RVADNB332
2.500	2.875	.281	RVADNB333
2.625	3.000	.281	RVADNB334
2.750	3.125	.281	RVADNB335
2.875	3.250	.281	RVADNB336
3.000	3.375	.281	RVADNB337
3.125	3.500	.281	RVADNB338
3.250	3.625	.281	RVADNB339
3.375	3.750	.281	RVADNB340

Rod Diameter	Groove Diameter	Groove Width	TSS Part No.
d_{Nh9}	D_{1H9}	$L_{1+.010}$	
3.500	3.875	.281	RVADNB341
3.625	4.000	.281	RVADNB342
3.750	4.125	.281	RVADNB343
3.875	4.250	.281	RVADNB344
4.000	4.375	.281	RVADNB345
4.125	4.500	.281	RVADNB346
4.250	4.625	.281	RVADNB347
4.375	4.750	.281	RVADNB348
4.500	4.875	.281	RVADNB349
4.625	5.125	.375	RVAENB426
4.750	5.250	.375	RVAENB427
4.875	5.375	.375	RVAENB428
5.000	5.500	.375	RVAENB429
5.125	5.625	.375	RVAENB430
5.250	5.750	.375	RVAENB431
5.375	5.875	.375	RVAENB432
5.500	6.000	.375	RVAENB433
5.625	6.125	.375	RVAENB434
5.750	6.250	.375	RVAENB435
6.000	6.500	.375	RVAENB437
6.250	6.750	.375	RVAENB438
6.500	7.000	.375	RVAENB439
6.750	7.250	.375	RVAENB440
7.000	7.500	.375	RVAENB441
7.250	7.750	.375	RVAENB442
7.500	8.000	.375	RVAENB443
7.750	8.250	.375	RVAENB444
8.000	8.500	.375	RVAENB445
8.500	9.000	.375	RVAENB446
9.000	9.500	.375	RVAENB447
9.500	10.000	.375	RVAENB448
10.000	10.500	.375	RVAENB449
10.500	11.000	.375	RVAENB450
11.000	11.500	.375	RVAENB451
11.500	12.000	.375	RVAENB452
12.000	12.500	.375	RVAENB453





Rod Diameter	Groove Diameter	Groove Width	TSS Part No.
$d_N h9$	$D_1 H9$	$L_1 + .010$	
12.500	13.000	.375	RVAENB454
13.000	13.500	.375	RVAENB455
13.500	14.000	.375	RVAENB456
14.000	14.500	.375	RVAENB457
14.500	15.000	.375	RVAENB458
15.000	15.500	.375	RVAENB459
15.500	16.000	.375	RVAENB460

The sizes listed in **bold** font are preferred sizes (more likely to be available for immediate shipment).



Turcon® Variseal® M2

TURCON[®] DOUBLE DELTA[®]

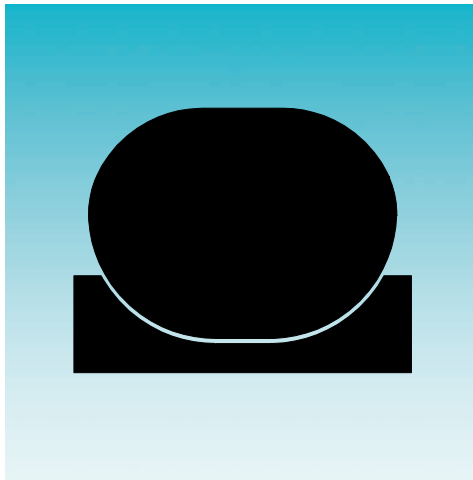

- Double-Acting -
- O-Ring-Energized Turcon[®] Slipper Seal -
- For O-Ring Grooves -

- Material -
- Turcon[®] -





■ Turcon® Double Delta®

Description

Turcon® Double Delta® is an O-Ring-energized plastic-faced seal. The seal is designed to expand and improve the service parameters of O-Rings and is installed in existing O-Ring grooves.

Double Delta® combines the flexibility and response of O-Rings with the wear and friction characteristics of the Turcon® materials in dynamic applications.

The figures below show the cross section of the Double Delta®.

The double-acting performance of the seal comes from the symmetrical cross section which allows the seal to respond to pressure in both directions.

Initial contact pressure is provided by radial compression of the O-Ring. When the system pressure is increased the O-Ring transforms this into additional contact pressure. The contact pressure of the seal is thereby automatically adjusted so sealing is ensured under all service conditions.

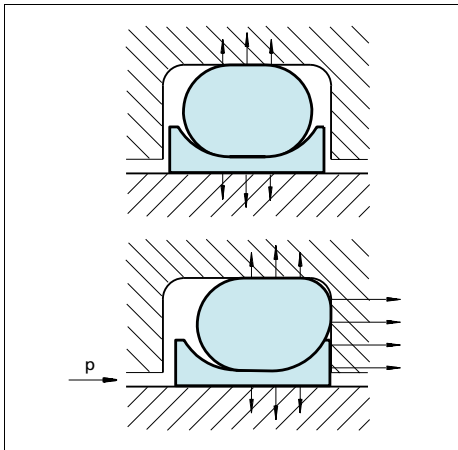

Figure 47 Turcon® Double Delta® with and without pressure

Advantages

- Compact groove dimensions and simple installation
- Low friction without stick-slip
- Resistance against wear and extrusion
- Rod seals available for all diameters from .080 to 40.000 inches (2 to 999.9 mm)

- Standard cross sections cover AS 568B and important metric O-Rings, other cross sections available on request
- Also fits groove dimensions per MIL-G-5514F

Application Examples

The Turcon® Double Delta® is preferably used as a double acting seal for hydraulic and pneumatic equipment in sectors such as:

- Machine tools
- Handling devices
- Manipulators
- Valves
- Chemical process equipments

It is particularly recommended for light duty and small diameter applications.

Technical Data

Operating conditions

Pressure: Up to 5,000 psi (35 MPa)

Velocity: Up to 50 ft/s (15 m/s)

Temperature: -49°F to +392°F (-45°C to +200°C)
(according to O-Ring material)

Media: Mineral oil, non-flammable fluids, environmentally safe fluids and others according to O-Ring material

Important Note:

The above data are maximum values and cannot be used at the same time. e.g. the maximum operating speed depends on material type, pressure, temperature and gap value. Temperature range also dependent on medium.



■ Materials

Standard Application:

- For hydraulic components with reciprocating movement in mineral oils containing zinc or medium with good lubricating performance and hard mating surface:

Seal Ring: Turcon® T46

Energizer: O-Ring NBR 70 shore A or FKM 70 shore A (depending on the temp.)

Special Application:

- Short stroke movements, poor lubricating fluids and soft mating surfaces.

Seal Ring: Turcon® T24

Energizer: O-Ring NBR 70 shore A or FKM 70 shore A (depending on the temp.)

- For low friction requirement in dynamic hydraulic components with good lubricating medium:

Seal Ring: Turcon® T05

Energizer: O-Ring NBR 70 shore A or FKM 70 shore A (depending on the temp.)

- For specific applications other material combinations as listed may also be used. Please contact your local Trelleborg Sealing Solutions sales office.

Material for the seal set:

Example: T05 plus FKM - O-Ring T05V

T46 plus NBR - O-Ring T46N

Table XXXIV Turcon® Materials for Double Delta®

Material, Applications, Properties	Code	O-Ring Material	Code	O-Ring Operating Temp.* °F	Mating Surface Material	PSI Max.
Turcon® T46 Standard material for hydraulics, high compressive strength, good sliding and wear properties, good extrusion resistance, BAM tested. Bronze filled Color: Grayish to dark brown	T46	NBR - 70 Shore A	N	-22 to +212	Steel, hardened Steel, chrome-plated Cast iron	5,000
		NBR - Low temp. 70 Shore A	T	-49 to +176		
		FKM - 70 Shore A	V	-14 to +392		
Turcon® T24 For all lubricating and non-lubricating hydraulic fluids, soft mating surfaces. Carbon filled Color: Black	T24	NBR - 70 Shore A	N	-22 to +212	Steel Steel, chrome-plated Cast iron Stainless steel Aluminium Bronze	3,625
		NBR - Low temp. 70 Shore A	T	-49 to +176		
		FKM - 70 Shore A	V	-14 to +392		
		EPDM - 70 Shore A	E**	-49 to +293		
Turcon® T05 For all lubricating hydraulic fluids, hard mating surfaces, very good sliding properties, low friction. Color: Turquoise	T05	NBR - 70 Shore A	N	-22 to +212	Steel, hardened Steel, chrome-plated	2,900
		NBR - Low temp. 70 Shore A	T	-49 to +176		
		FKM - 70 Shore A	V	-14 to +392		

* The O-Ring Operation Temperature is only valid in mineral hydraulic oil. BAM: Tested by "Bundesanstalt Materialprüfung, Germany".

□ Highlighted materials are standard. ** Material not suitable for mineral oils.



■ Installation Recommendation (Inch Rod Series)

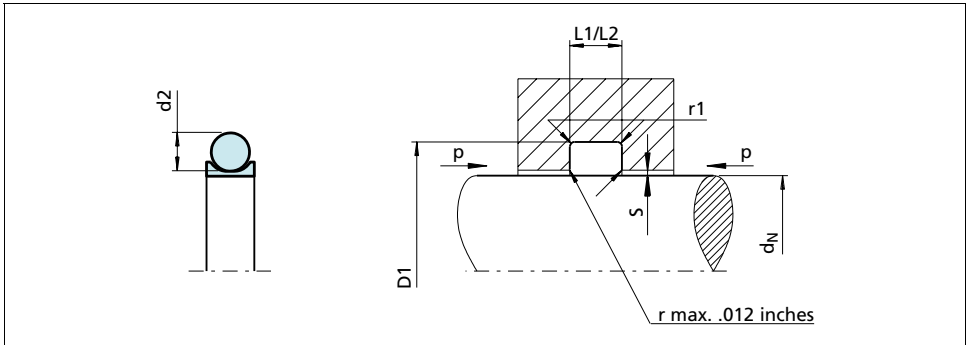

Figure 48 Installation drawing

Table XXXV Installation Recommendation

Dash Sizes	Rod Diameter			Groove Diameter	Groove Width		Radius	Radial Clearance			O-Ring Cross-Section
	d_N f8/h9				D_1 H9	L_1 +.008*		L_2 +.008**	S max.		
	Standard Application	Light Application	Heavy Duty Application	10 MPa 1500 psi			20 MPa 3000 psi		40 MPa 5800 psi	d_2	
006-028	.125 - .437	.500 - 1.375	-	$d_N + .110$.093	.138	.005	.004	.003	.002	.070
104-151	.500 - .812	.875 - 3.000	.125 - .437	$d_N + .176$.140	.171	.005	.006	.004	.003	.103
201-250	.875 - 1.500	1.625 - 5.000	.187 - .812	$d_N + .242$.187	.208	.010	.008	.006	.003	.139
309-353	1.625 - 4.375	.437 - 5.000	.437 - 1.500	$d_N + .370$.281	.311	.020	.010	.008	.004	.210
425-461	4.500 - 16.000	-	-	$d_N + .474$.375	.408	.020	.012	.010	.006	.275

* L1 is for "0" Back-up width groove - RD00_B series

** L2 is for "1" Back-up width groove - RD01_B series



Turcon® Double Delta®

Ordering example

Turcon® Double Delta®, complete with O-Ring, standard range, series RD00 (from Table XXXV).

Dash No.: 445
 TSS Part No.: RD000B445 (from Table XXXVI)

Select the material from Table XXXIV. The corresponding code numbers are appended to the TSS Part No. (from Table XXXVI). Together they form the TSS Article No.

For all intermediate sizes not shown in Table XXXVI, the TSS Article No. can be determined from the example opposite.

TSS Article No.	RD00	0	B	445	-	T46	N
TSS Series No.							
RD00 - 0 Back-up width groove L ₁							
RD01 - 1 Back-up width groove L ₂							
Without notch (Standard) (substitute "N" if notch is required)							
Groove Standard							
Dash Size							
Quality Index (Standard)							
Material code (Seal Ring)							
Material code (O-Ring)							

Table XXXVI Installation dimensions / TSS Part No

Rod Diameter	Groove Diameter	Groove Width	TSS Part No.	Groove Width	TSS Part No.
d _N h9	D ₁ H9	L ₁ +.008		L ₂ +.008	
.187	.297	.093	RD000B008	.138	RD010B008
.219	.329	.093	RD000B009	.138	RD010B009
.250	.360	.093	RD000B010	.138	RD010B010
.312	.422	.093	RD000B011	.138	RD010B011
.375	.485	.093	RD000B012	.138	RD010B012
.437	.547	.093	RD000B013	.138	RD010B013
.500	.610	.093	RD000B014	.138	RD010B014
.563	.672	.093	RD000B015	.138	RD010B015
.625	.735	.093	RD000B016	.138	RD010B016
.688	.797	.093	RD000B017	.138	RD010B017
.750	.860	.093	RD000B018	.138	RD010B018
.813	.922	.093	RD000B019	.138	RD010B019
.875	.985	.093	RD000B020	.138	RD010B020
.938	1.047	.093	RD000B021	.138	RD010B021
1.000	1.176	.140	RD000B120	.171	RD010B120
1.063	1.238	.140	RD000B121	.171	RD010B121
1.125	1.301	.140	RD000B122	.171	RD010B122
1.188	1.363	.140	RD000B123	.171	RD010B123
1.250	1.426	.140	RD000B124	.171	RD010B124
1.313	1.488	.140	RD000B125	.171	RD010B125
1.375	1.551	.140	RD000B126	.171	RD010B126
1.438	1.613	.140	RD000B127	.171	RD010B127
1.500	1.676	.140	RD000B128	.171	RD010B128
1.563	1.738	.140	RD000B129	.171	RD010B129

The sizes listed in **bold** font are preferred sizes (more likely to be available for immediate shipment). Larger sizes up to 102 inches (2,600 mm) available upon request.



Rod Diameter	Groove Diameter	Groove Width	TSS Part No.	Groove Width	TSS Part No.
d_N h9	D_1 H9	L_1 +.008		L_2 +.008	
1.625	1.801	.140	RD000B130	.171	RD010B130
1.688	1.863	.140	RD000B131	.171	RD010B131
1.750	1.926	.140	RD000B132	.171	RD010B132
1.813	1.988	.140	RD000B133	.171	RD010B133
1.875	2.051	.140	RD000B134	.171	RD010B134
1.938	2.113	.140	RD000B135	.171	RD010B135
2.000	2.176	.140	RD000B136	.171	RD010B136
2.063	2.238	.140	RD000B137	.171	RD010B137
2.125	2.301	.140	RD000B138	.171	RD010B138
2.188	2.363	.140	RD000B139	.171	RD010B139
2.250	2.426	.140	RD000B140	.171	RD010B140
2.313	2.488	.140	RD000B141	.171	RD010B141
2.375	2.551	.140	RD000B142	.171	RD010B142
2.438	2.613	.140	RD000B143	.171	RD010B143
2.500	2.676	.140	RD000B144	.171	RD010B144
2.625	2.867	.187	RD000B231	.208	RD010B231
2.750	2.992	.187	RD000B232	.208	RD010B232
2.875	3.117	.187	RD000B233	.208	RD010B233
3.000	3.242	.187	RD000B234	.208	RD010B234
3.125	3.367	.187	RD000B235	.208	RD010B235
3.250	3.492	.187	RD000B236	.208	RD010B236
3.375	3.617	.187	RD000B237	.208	RD010B237
3.500	3.742	.187	RD000B238	.208	RD010B238
3.625	3.867	.187	RD000B239	.208	RD010B239
3.750	3.992	.187	RD000B240	.208	RD010B240
3.875	4.117	.187	RD000B241	.208	RD010B241
4.000	4.242	.187	RD000B242	.208	RD010B242
4.125	4.367	.187	RD000B243	.208	RD010B243
4.250	4.492	.187	RD000B244	.208	RD010B244
4.375	4.617	.187	RD000B245	.208	RD010B245
4.500	4.742	.187	RD000B246	.208	RD010B246
4.625	4.867	.187	RD000B247	.208	RD010B247
4.750	4.992	.187	RD000B248	.208	RD010B248
4.875	5.117	.187	RD000B249	.208	RD010B249
5.000	5.474	.375	RD000B429	.408	RD010B429
5.125	5.599	.375	RD000B430	.408	RD010B430

The sizes listed in **bold** font are preferred sizes (more likely to be available for immediate shipment).
Larger sizes up to 102 inches (2,600 mm) available upon request.



Turcon® Double Delta®

Rod Diameter	Groove Diameter	Groove Width	TSS Part No.	Groove Width	TSS Part No.
d_N h9	D_1 H9	L_1 +.008		L_2 +.008	
5.250	5.724	.375	RD000B431	.408	RD010B431
5.375	5.849	.375	RD000B432	.408	RD010B432
5.500	5.974	.375	RD000B433	.408	RD010B433
5.625	6.099	.375	RD000B434	.408	RD010B434
5.750	6.224	.375	RD000B435	.408	RD010B435
5.875	6.349	.375	RD000B436	.408	RD010B436
6.000	6.474	.375	RD000B437	.408	RD010B437
6.250	6.724	.375	RD000B438	.408	RD010B438
6.500	6.974	.375	RD000B439	.408	RD010B439
6.750	7.224	.375	RD000B440	.408	RD010B440
7.000	7.474	.375	RD000B441	.408	RD010B441
7.250	7.724	.375	RD000B442	.408	RD010B442
7.500	7.974	.375	RD000B443	.408	RD010B443
7.750	8.224	.375	RD000B444	.408	RD010B444
8.000	8.474	.375	RD000B445	.408	RD010B445
8.500	8.974	.375	RD000B446	.408	RD010B446
9.000	9.474	.375	RD000B447	.408	RD010B447
9.500	9.974	.375	RD000B448	.408	RD010B448
10.000	10.474	.375	RD000B449	.408	RD010B449

The sizes listed in **bold** font are preferred sizes (more likely to be available for immediate shipment).
Larger sizes up to 102 inches (2,600 mm) available upon request.

POLYPAC[®] - BALSELE

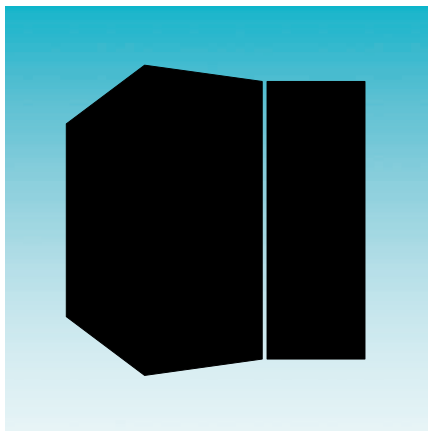

- **Single-Acting** -
- **Compact Seal** -
- **Without and with Back-up Ring** -

- **Material** -
- **Fabric-Reinforced NBR + POM** -





■ Balsele

Description

The Balsele is a compact rod seal consisting of an elastomeric sealing element and an integrated fabric reinforced base.

Due to the radial pre-load, an excellent sealing performance will be achieved even at low pressures. The fabric reinforced base prevents the seal from extrusion. Where extrusion gaps are greater than those specified or for higher pressure conditions, the series B/NEI with incorporated anti-extrusion ring shall be selected.

Design

- 1) Sealing element manufactured from a specially developed nitrile compound particularly resistant to compression set. The sealing lips are produced to give optimum efficiency and wear resistance.
- 2) The reinforced base of the seal element is of cotton fabric impregnated with nitrile elastomer and vulcanized with the sealing element 1, thus forming an integral component.
- 3) Guide rings or anti-extrusion rings are made from acetal resin. As previously described, these rings maintain the seal in the optimum position for maximum performance, and minimize all possible extrusion gaps.

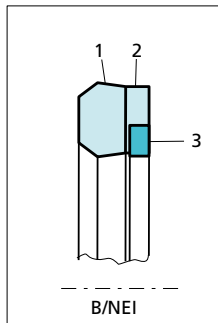
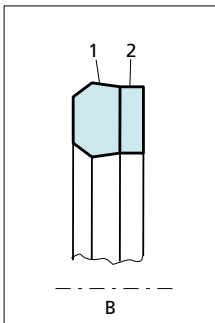

Please contact your local Trelleborg Sealing Solutions sales office for inch dimensions. For metric dimensions, please use the metric catalog.

Advantages

- Small cross sections
- Good chemical resistance
- Large size range
- No hydrolyses problems
- Wide temperature range

Application Examples

- Standard hydraulic cylinders (low to medium duty)
- Mobile hydraulic
- Water-based fluids equipment
- After market
- Presses

Technical Data

Operating conditions

Pressure:	Up to 3,625 psi (25 MPa) (Type B) Up to 5,800 psi (40 MPa) (Type B/NEI)
Velocity:	Up to 1.65 ft/s (0.5 m/s)
Temperature:	-22°F to +266°F (-30°C to +130°C)
Media:	Mineral oil, water, air

Important Note:

The above data are maximum values and cannot be used at the same time. e.g. the maximum operating speed depends on material type, pressure, temperature and gap value. Temperature range also dependent on medium.

Materials

For type B:
NBR + cotton fabric
Material code N8C0

for type B/NEI:
NBR + cotton fabric
Back-up Ring material POM
Material code N8C0



ZURCON[®] L-CUP[®]

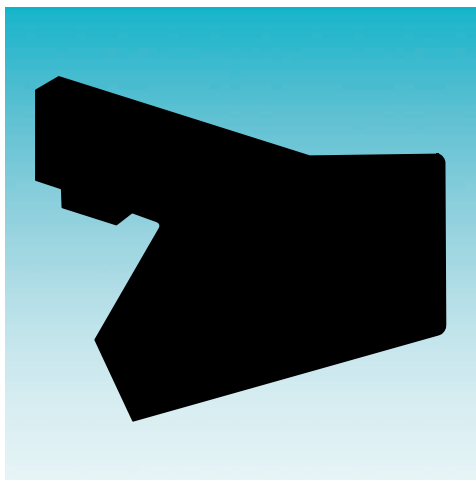

- Single-Acting -
- Low-friction Zurcon[®] U-Cup -

- Material -
- Zurcon[®] -





■ Zurcon® L-Cup®

Introduction

The rod sealing system is the most critical part of a hydraulic cylinder. Therefore it is expected that a rod sealing system performs under leak-free conditions in the static and dynamic state. Moreover it has to fulfill the lifetime of several thousand hours.

To meet these requirements, Trelleborg Sealing Solutions has developed the Zurcon® L-Cup®, a highly effective and innovative rod sealing component.

***Patent for: Europe No. EP 0724693**

***Patent for: US No. 5,649,711**

***Patent for: China No. ZL 94193869.7**

Zurcon® L-Cup® is a trade name.

Description

Zurcon® L-Cup® is a single acting polyurethane rod seal with a unique design offering a hydrodynamic back-pumping ability over the complete working pressure range. The pressure-independent, hydrodynamic sealing ability of this new sealing element requires no lubrication reservoir in the sealing area and ensures a constant and controlled pressure distribution over a wide pressure range.

The advantages of the Zurcon® L-Cup® design lead to the following improved properties:

Advantages

- Hydrodynamic back-pumping ability over the complete working pressure range
- Low friction and therefore a reduction of heat generated
- Low breakout force even after a long period of non-operation
- Very low stick-slip
- Low increase in friction at increasing pressure
- High extrusion resistance
- Optimum geometry of the static sealing lip for higher sealing ability
- No entrapped oil and grease between seal and groove (due to notches)
- No pressure build-up between seal and groove OD
- Long service life

The Zurcon® L-Cup® was designed in accordance with customers' demands.

- Groove dimensions according to ISO 5597 Part 2
- Interchangeable with existing U-Cup grooves

- Installation into closed grooves
- Wear and extrusion resistant high-performance polyurethane

Application Examples

Zurcon® L-Cup® can be used in all applications in which previously a conventional U-Cup was applied, such as:

- Fork lifts
- Agricultural machines
- Light and medium mobile hydraulics
- Industrial hydraulics
- Machine tools
- Injection molding machines

Another preferred solution for tandem rod sealing systems is the combination with the Turcon® Stepseal® 2K as primary seal and L-Cup® as secondary seal, in conjunction with a double acting scraper.

Technical Data

Operating conditions

Pressure: Up to 5,800 psi (40 MPa)

Velocity: Up to 1.65 ft/s (0.5 m/s)

Temperature: -31°F to +230°F (-35°C to +110°C)

Media: Hydraulic fluids based on mineral oil

Important Note:

The above data are maximum values and cannot be used at the same time. e.g. the maximum operating speed depends on material type, pressure, temperature and gap value. Temperature range also dependent on medium.

Please contact your local Trelleborg Sealing Solutions sales office for inch dimensions. For metric dimensions, please use the metric catalog.



Zurcon® L-Cup®

POLYPAC[®] VEEPAC CH/G5

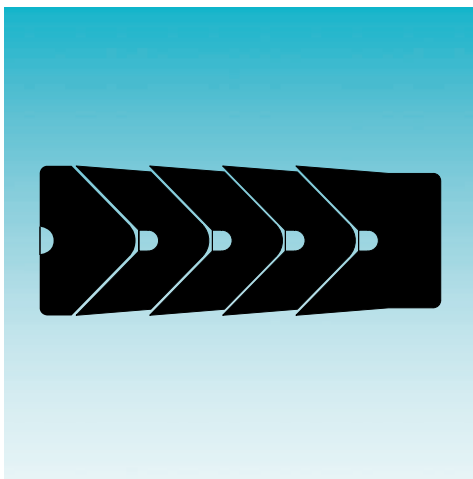

- **Single-Acting** -
- **Chevron Vee Packing Set** -
- **With Support and Pressure-Energizing Ring** -

- **Material** -
- **Fabric-Reinforced Rubber, Rubber, POM or PTFE** -





■ POLYPAC® Veepac CH/G5 Set

Description

Veepac is a set of fabric-reinforced Chevron rings comprised of a support ring (1), sealing rings (2) and a pressure-energizing ring (3). In the packing set the energizing axial force is transferred between the individual packing rings so that each ring is pressed into positive contact with the rod surface, in addition to the standard material, special material grades are available for a large variety of working conditions. The figure shows the Veepac design.

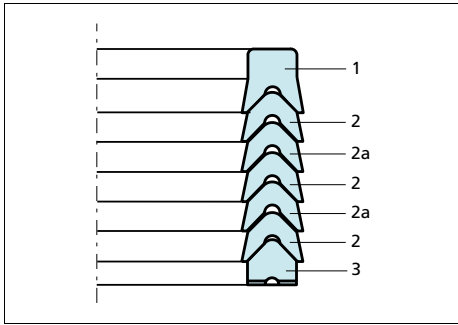

Figure 51 Veepac design

- 1) "U" or base rings in standard version manufactured in reinforced fabric comprised of layers of cotton impregnated with nitrile rubber compounded to resist extrusion. This component supports the Vee Rings for effective performances.
- 2) V-Rings are made of reinforced cotton fabric and nitrile elastomer, in standard version, to give good resilience, sealing efficiency and extrusion resistance.

Due to their specific design, Vee Rings are sensitive to fluid pressure variations, enabling them to deflect throughout their radial section, increasing the seal loading and effectiveness in proportion to the pressures applied.
- 2a) V-Rings are made of pure elastomer for high sealing efficiency.
- 3) Energizer or spreader rings are manufactured in acetal resin or PTFE. The function of this component is to ensure a uniform pressure distribution.

Advantages

- Very robust seal
- Non sensitive
- Adjustable
- Easy replacement in the field with split rings
- Extensive range of sizes (see symmetrical seals)
- Requires non super mating surfaces

Application Examples

- Mining equipment (with approvals)
- Excavators
- Steel mills
- Water hydraulic
- Presses
- Ship hydraulics
- Stabilizer cylinders on cranes
- Continuous casting equipment

Technical Data

Operating conditions

Pressure:	Up to 5,800 psi (40 MPa)
Velocity:	Up to 1.65 ft/s (0.5 m/s)
Temperature:	-32°F to +392°F (-30°C to +200°C) depending on material
Media:	Hydraulic fluids Mineral oil, water glycol, water emulsions

Important Note:

The above data are maximum values and cannot be used at the same time. e.g. the maximum operating speed depends on material type, pressure, temperature and gap value. Temperature range also dependent on medium.

Please contact your local Trelleborg Sealing Solutions sales office for inch dimensions. For metric dimensions, please use the metric catalog.



POLYPAC® Veepac CH/G5

POLYPAC[®] - SELEMASTER SM

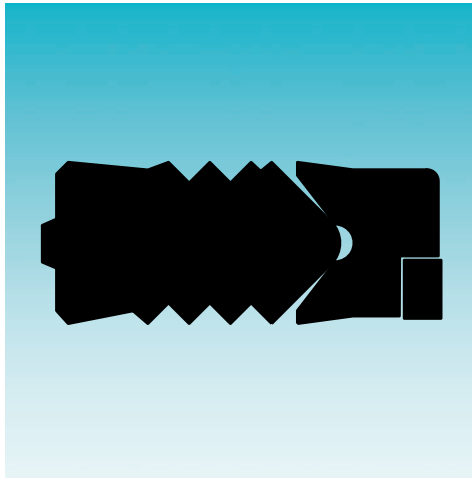

- **Single-Acting** -
- **Compact Rod Seal** -
- **With Anti-Extrusion Ring** -

- **Material** -
- **Rubber + Fabric-Reinforced Rubber + POM** -





■ Selemaster SM

Description

The rod seal range has been designed to meet the needs of hydraulic equipment operating at high pressures and subjected to severe loading and vibration conditions.

The main sealing element is manufactured in a highly compression set resistant nitrile. The most important quality of this element is the design of the multiple sealing lips for maximum sealing efficiency and end face configuration, which ensures that the Selemaster can tolerate vibrations and severe misalignment.

The support ring is made in cotton fabric reinforced nitrile elastomer. The "U" shape is energized when pressure is applied.

The last element is the anti-extrusion ring manufactured in POM.

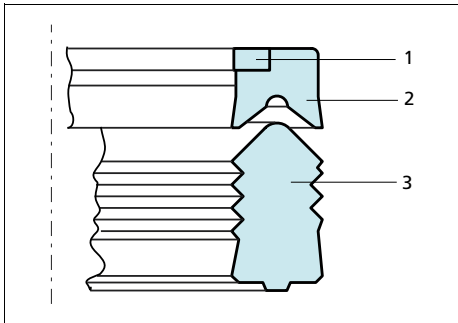

Figure 53 Selemaster design
 1) POM anti-extrusion ring
 2) Support ring in cotton fabric reinforced nitrile, NBR 80 Shore A
 3) Sealing element in nitrile, NBR 80 Shore A

Please contact your local Trelleborg Sealing Solutions sales office for inch dimensions. For metric dimensions, please use the metric catalog.

Note

- For low-temperature applications -58°F to +230°F (-50°C to +110°C) a special material - code N7C0 - Polypac Ref.: /1AX - 2187 is available.
- For a simple change in the field Selemaster SM in a cut version (Polypac Ref.: /1AXLS) is available on request.

Advantages

- High sealing efficiency
- Effective sealing during vibration and shock loading
- Extrusion resistance at high pressure

Application Examples

- Earth moving machines
- Excavators
- Lift platforms

Technical Data

Operating conditions

Pressure: Up to 10,150 psi (70 MPa)

Velocity: Up to 1.65 ft/s (0.5 m/s)

Temperature: -40°F to +266°F (-40°C to +130°C)

Media: Hydraulic fluids
 Mineral oil-based hydraulic fluids,
 water and water/glycol emulsions

Groove type: Open

Important Note:

The above data are maximum values and cannot be used at the same time. e.g. the maximum operating speed depends on material type, pressure, temperature and gap value. Temperature range also dependent on medium.



POLYPAC® - Selemaster SM

HYDRAULIC SEALS PISTON SEALS

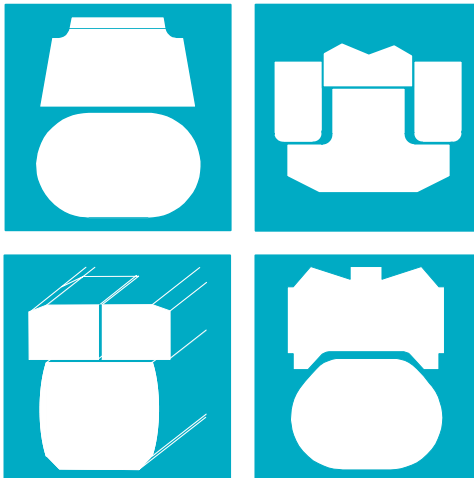



Piston Seals

Contents

Choice of the Sealing Element	4
Design Instructions	8
Installation of Piston Seals	10
Zurcon® Wynseal	15
Turcon® Glyd Ring® T	21
Zurcon® Glyd Ring® P (ISO)	29
Turcon® Glyd Ring®	35
Turcon® Glyd Ring C	43
Zurcon® Glyd Ring® P	51
Turcon® Stepseal® 2K	57
Turcon® Double Delta®	67
Turcon® CST Seal	77
Turcon® AQ-Seal®	85
Turcon® AQ-Seal® 5	93
Turcon® Variseal® M2	101
POLYPAC® PHD/P Seal	109
POLYPAC® - Veepac CH/G1	113
Compact Seal DAS Type A/B - POLYPAC® DBM	117
Selemaster DSM	121

■ Choice of the Sealing Element

Sealing elements have a decisive influence on the design, function and service life of hydraulic and pneumatic cylinders and systems.

This also applies to piston seals. Leak tightness, wear and gap extrusion resistance, resistance to process media and temperatures, low friction, compact form and simple installation are required to meet the demands of the industry.

The significance of these parameters and their limits depends on the requirements of the specific application. Trelleborg Sealing Solutions has developed a complete range of seals which, due to their optimized geometries and designs and the use of high-quality materials such as Turcon® and Zurcon®, satisfies the technical and economic demands of the industry.

In order to be in a position to select the most appropriate seal type and material, it is necessary to first define all the desired functional parameters. Table I can then be used to make an initial selection of seals according to the specific requirements of the application.

The second column of the table contains the page number on which general information and specific design and installation instructions on the particular seal type and materials (or material combinations with multi-element seals, e.g. Turcon® Glyd Ring® T) can be found.

Furthermore, attention is drawn to the quality of the mating surface. We recommend that the limits specified there be observed, as they have a decisive influence on the functionality and service life of the system.

The final choice of seal type and material must also take into account the detailed information on the seal elements.

Please do not hesitate to contact your local Trelleborg Sealing Solutions sales office for further information on specific applications and special technical questions.

Notes

All multi-element standard piston seals, e.g. Glyd Ring® T, are supplied as complete seal sets. The supply includes the seal and matching elastomer energizing elements.

Designs of seals no longer contained in this catalog continue to be available. For all new applications we recommend the use of the seal types and preferred sizes (ISO series, wherever possible) listed in this catalog.







Other combinations of Turcon® materials and special designs can be developed and supplied for special applications in all intermediate sizes up to 106 inches (2.700 mm) diameter.

The sizes contained in this catalog are generally available from stock or can be supplied on short notice. We reserve the right to modify our supply program.



Piston Seals







Table I Selection Criteria for Piston Seals

Seal		Application			Standard	Size Range	Action		Technical Data*			Recommended Seal Material				
Type	Page	Field of Application	Light	Medium	Heavy	ISO/DIN	Inch	Single	Double	Temp. Range**	Velocity		Pressure			
											°F	ft/s	PSI Max.			
 Zurcon [®] Wynseal	15	Standard cylinders	●	●		7425/1	.5 - 20	X		-31/ +230	1.6	3,625	Zurcon [®] Z20 + NBR			
		Mobile hydraulics	●	●								5,800	Zurcon [®] Z05 + NBR			
 Turcon [®] Glyd Ring [®] T	21	Mobile hydraulics	●	●	●	7425/1	.31 - 106	X		-49/ +392	50	8,700	Turcon [®] T46			
		Standard cylinders	●	●	●							3,625	Turcon [®] T40			
		Machine tools	●	●	●							.31 - 90	-49/ +212	6.5	11,600	Zurcon [®] Z51
		Injection molding machines	●	●	●											
		Presses	●	●	●											
Automotive industry	●	●	●													
 Zurcon [®] Glyd Ring [®] P (ISO)	29	Mobile hydraulics		●	●	7425/1	1 - 10	X		-40/ +230	3.2	7,500	Zurcon [®] Z66			
		Construction machinery		●	●											
		Agriculture machinery		●	●											
 Turcon [®] Glyd Ring [®]	35	Mobile hydraulics	●	●	●	7425/1	.31 - 106	X		-49/ +392	50	8,700	Turcon [®] T46			
		Machine tools	●	●	●							8,700	Turcon [®] T29			
		Injection molding machines	●	●	●							2,900	Turcon [®] T05			
		Presses	●	●	●							.31 - 90	-49/ +212	6.5	11,600	Zurcon [®] Z51
 Turcon [®] Glyd Ring [®] C	43	Special cylinder	●	●	●	-	.25 - 106	X		-49/ +390	50	8,700	Turcon [®] T46			
		Pumps and valves	●	●	●							8,700	Turcon [®] T29			
		Machine tools	●	●	●							2,900	Turcon [®] T05			
		Robotics/manipulators	●	●	●							.25 - 90	-49/ +212	6.4	11,600	Zurcon [®] Z51
 Zurcon [®] Glyd Ring [®] P	51	Mobile hydraulics		●	●	-	1 - 10	X		-40/ +230	3.2	7,500	Zurcon [®] Z66			
		Construction machinery		●	●											
		Agriculture machinery		●	●											

* The data below are maximum values and cannot be used at the same time. The max. pressure depends on temperature and gap dimension.

** Temperature range depends on choice of elastomer material and media. In the case of Turcon[®] seals in unpressurized applications in temperatures below 32°F please contact your local sales office.

Piston Seals



Seal		Application			Standard	Size Range	Action		Technical Data*			Recommended Seal Material	
Type	Page	Field of Application					ISO/DIN	Inch	Single	Double	Temp. Range**		Velocity
		Light	Medium	Heavy							°F	ft/s	PSI Max.
 Turcon® Stepseal® 2K	57	Mobile hydraulics	•	•	•	7425/1	.31 - 106	X		-49/ +392	50	10,150	Turcon® T46
		Standard cylinders	•	•	•							10,150	Turcon® T29
		Machine tools	•	•	•								
		Injection molding machines	•	•	•								
		Presses	•	•	•							.31 - 90	-49/ +212
 Turcon® Double Delta®	67	Machine tools	•	•	-	.18 - 102	X		-49/ +392	50	2,900	Turcon® T05	
		Handling devices/ manipulators	•	•							5,100	Turcon® T46	
		Valves	•	•							3,625	Turcon® T24	
		Chemical industry	•	•									
 Turcon® CST Seal	77	Hydraulic	•	•	-	1 - 106	X		-85/ +752	16	7,500	Turcon® T46	
		Mobile hydraulics	•	•									
 Turcon® AQ-Seal®	85	Standard cylinders	•	•	7425/1	.5 - 27.5	X		-49/ +392	6.5	5,800	Turcon® T46	
		Piston accumulators	•	•							5,800	Turcon® T10	
 Turcon® AQ-Seal® 5	93	Mobile hydraulics	•	•	-	1.5 - 27.5	X		-49/ +392	10	8,700	Turcon® T46	
		Holding cylinders	•	•							8,700	Zurcon® Z51	
		Piston accumulators	•	•									
 Turcon® Variseal® M2	101	High and low temperatures	•	•	3771	.23 - 98	X		-97/ +500	50	6,525	Turcon® T40	
		Aggressive media	•	•	MIL-G- 5514F	.23 - 102					2,900	Turcon® T46	
		Foodstuffs	•	•									
 Compact Seal PHD/P	109	Mobile hydraulics	•	•	-	1.5 - 8	X		-31/ +230	1.6	5,800	Zurcon® Z20 + NBR + POM	
		Excavators	•	•									
		Heavy duty hydraulic cylinders	•	•									

* The data below are maximum values and cannot be used at the same time. The max. pressure depends on temperature and gap dimension.

** Temperature range depends on choice of elastomer material and media. In the case of Turcon® seals in unpressurized applications in temperatures below 32°F please contact your local sales office.



Piston Seals

Seal		Application			Standard	Size Range	Ac-tion		Technical Data*			Recom-mended Seal Material
									Temp. Range**	Velocity	Pressure	
Type	Page	Field of Application			ISO/DIN	Inch	Single	Double	°F	ft/s	PSI Max.	
			Light	Medium								
Compact Seal DAS/DBM 	117	Standard cylinders	●	●	6547	.75 - 10	X		-22/+230	1.6	5,100	NBR + TPE + POM
		Holding cylinders	●	●								
		Agricultural machinery	●	●								
Veepac CH/G1 	113	Mining equipment	●	●	-	1.5 - 10	X		-22/ +392	1.6	5,800	Fabric reinforced Rubber
		Excavators	●	●								
		Steel mills	●	●								
		Presses	●	●								
Selemaster DSM 	121	Mining equipment	●	●	-	1.5 - 14	X		-22/ +266	1.6	10,150	Fabric reinforced Rubber + POM
		Excavators	●	●								
		Steel mills	●	●								
		Presses	●	●								

* The data below are maximum values and cannot be used at the same time. The max. pressure depends on temperature and gap dimension.

** Temperature range depends on choice of elastomer material and media. In the case of Turcon® seals in unpressurized applications in temperatures below 32°F please contact your local sales office.

Piston Seals

■ Design Instructions

Lead-in chamfers

Piston seals are always fitted with an interference fit. In order to avoid damage during installation, lead-in chamfers and rounded edges must be provided on the cylinder barrel (Figure 1). If this is not possible for design reasons, a separate installation tool must be used.

The minimum lead-in chamfer depends on the profile size of the seal and can be seen in the following tables.

Generally ΔD_N min. from Table II, III and IV is recommended but ΔD_N must also exceed $0.015 \times$ bore diameter D_N (relevant for big diameter cylinders).

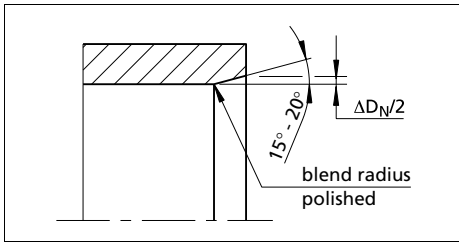

Figure 1 Lead-in chamfer

Table II Elastomer Energized Seals

Lead-in Chamfer Diameter increase ΔD_N min.	Groove Width L1*
.043	.090
.055	.126
.075	.165
.106	.250
.140	.319
.158	.374
.217	.543

* The groove width can be found in table "Installation dimensions" for Turcon® Glyd Ring®, Turcon® Glyd Ring® T, Turcon® AQ-Seal®S, Turcon® Stepseal® 2K, Zurcon® Wynseal and Turcon® AQ-Seal®.

Table III Compact Seal and Variseal®

Lead-in Chamfer Diameter increase ΔD_N min.	Compact Seal Groove Depth**	Turcon® Variseal® M2 Series
.043	.140	
.043	.158	
.055	.197	
.087	.295	PVAA
.106	.393	PVAB,PVAC
.140	.492	
.158	.590	PVAD
.217	.787	
.255		PVAE
.374		PVAF

** The groove depth is calculated as $(D - D1)/2$. The dimensions for D and D1 can be found in the tables "Installation dimensions," from chapter "Compact Seal DAS and DBM."

Table IV Double Delta®

Lead-in Chamfer*** Diameter increase ΔD_N min.	O-Ring Cross Section**** d_2	
.043	.070	-
.055	.094	.103
.075	.118	.139
.106	.210	.225
.140	.275	.331

*** Though not less than 1.5 % of service diameter (bore/rod diameter).

**** The O-Ring cross section d_2 can be found in the in the appropriate table "Installation Dimensions," from chapter "Double Delta®."

Piston Seals

Surface Roughness DIN EN ISO 4287

The functional reliability and service life of a seal depends to a very great extent on the quality and surface finish of the mating surface to be sealed.

Scores, scratches, pores and concentric or spiral machining marks are not permitted. Higher demands must be made on the surface finishes of dynamic surfaces than those of static mating surfaces.

The characteristics most frequently used to describe the surface microfinish R_a , R_z and R_{max} are defined in DIN EN ISO 4287. These characteristics alone, however, are not sufficient for assessing the suitability of seal technology. The material contact area of the surface roughness profile R_{mr} in accordance with DIN EN ISO 4287 should be demanded. The significance of this surface specification is illustrated in Fig. 2. It shows clearly that specification of R_a and R_z alone does not describe the surface roughness profile accurately enough for the seal technology and is not sufficient for assessing the suitability. The material contact area R_{mr} is essential for assessing surfaces, as this parameter is determined by the specific surface roughness profile. This depends on the machining process employed.

Trelleborg Sealing Solutions recommends that the following surface finishes be observed:

Table V Surface Roughness

Surface Roughness μinch			
Parameter	Mating Surface		Groove Surface
	Turcon® Materials	Zurcon® and Rubber	
R_{max}	25 - 100	40 - 160	< 625
R_z DIN	16 - 63	25 - 100	< 400
R_a	2 - 8	4 - 16	< 63

The material contact area R_{mr} should be approx. 50 to 70%, determined at a cut depth $c = 0.25 \times R_z$, relative to a reference line of C_{ref} . 5%.

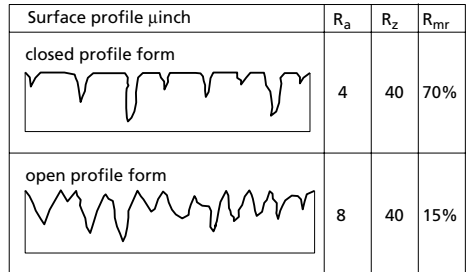

Figure 2 Profile forms of surfaces

Figure 2 shows two surface profiles, both of which exhibit nearly the same value for R_z in the test procedure. The difference becomes obvious only when the material contact area of the surface roughness profiles are compared. This shows that the upper roughness profile with $R_{mr} = 70\%$ has the better seal/mating surface ratio.

■ Installation of Piston Seals

General Installation Instructions

The following points should be observed before installation of the seals:

- Ensure the cylinder tube has a lead-in chamfer; if not, use an installation sleeve
- Deburr and chamfer or round sharp edges, cover the tips of screw threads
- Remove machining residues such as chips, dirt and other foreign particles and carefully clean all parts
- The seals can be installed more easily if they are greased or oiled. Attention must be paid to the compatibility of the seal materials with these lubricants. Use only grease without solid additives (e.g. molybdenum disulphide or zinc sulphide).
- Use no sharp-edged installation tools

Installation in Split Grooves

Installation in split grooves is simple. The sequence of installation corresponds to the configuration of the seal. Individual seal elements must not be allowed to twist. During final installation (installation of the piston in the cylinder), elastomer or spring-preloaded seals must be sized. The corresponding cylinder barrel can be used for this purpose, provided it has a long lead-in chamfer. Alternatively, a sizing sleeve should be used.

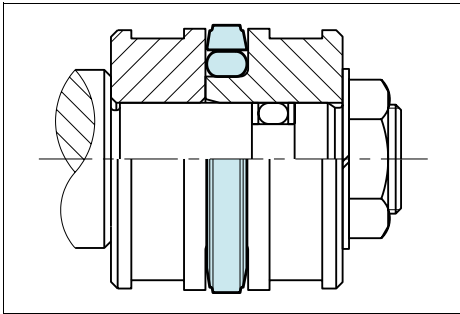

Figure 3 Installation in a split groove

Installation in Closed Grooves

- Without installation aids

If observing the instructions in the chapter "General installation instructions," installation of Compact Seal and Wynseal seal elements in closed grooves is relatively simple.

For Turcon® and Zurcon® seals, the use of installation aids is recommended. If installation has to be performed without

installation aids, however, the following points should be observed:

Turcon® seals can be installed more easily by heating in oil or water or using a hot air fan to approx. 80°C to 100°C (176°F to 212°F) (expanding and then shrinking back to the original form).

Use no sharp edged tools to expand the seal rings.

Sizing of the seal ring is achieved with a separate sizing sleeve, or with the cylinder tube provided this has lead-in chamfers equivalent to 2x the values from Table II.

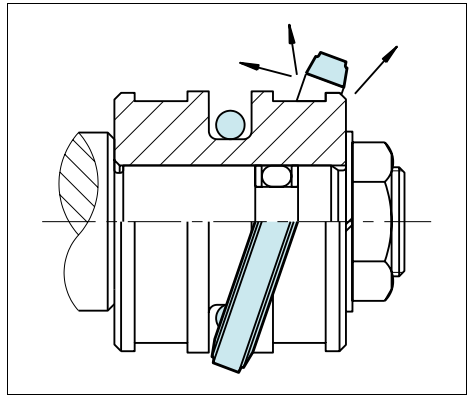

Figure 4 Fitting the seal ring onto the O-Ring in the groove

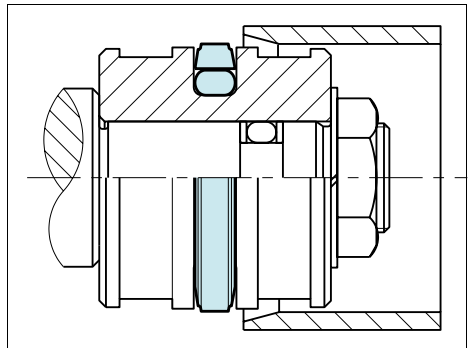

Figure 5 Sizing of the installed seal

Piston Seals

Installation in Closed Grooves

- With installation aids

Use of a three-piece installation tool is recommended for the series production installation of Turcon® and Zurcon® seal elements. The tool consists of:

- Installation sleeve
- Expanding sleeve
- Sizing sleeve

All these parts should be made of a polymer material (e.g. PA6) with good sliding characteristics and low abrasiveness to avoid damage to the seals.

In view of the wide range of sizes and the application-specific installation conditions, these installation tools cannot be supplied as standard by Trelleborg Sealing Solutions.

On request, however, we will gladly provide specimen drawings to allow you to manufacture these tools.

The sequence of installation is illustrated in Fig. 6 to 8. Note, however, that the installation of Turcon® seal elements should be performed quickly in order to ensure optimum recovery of the seal ring.

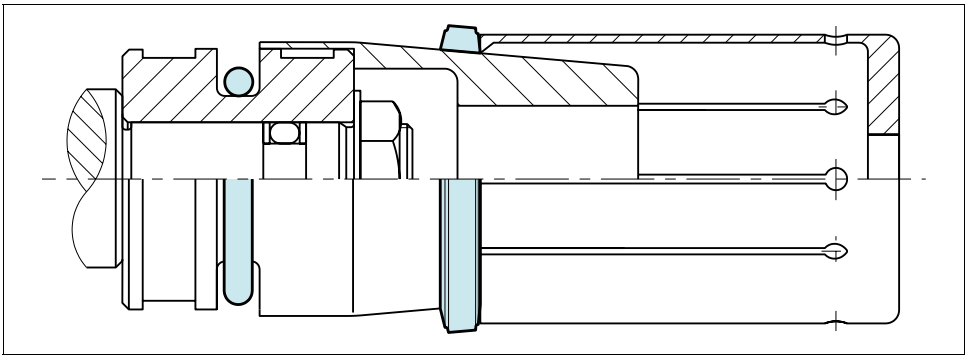

Figure 6 Expanding the Turcon® or Zurcon® sealing element using an expanding sleeve over the installation sleeve

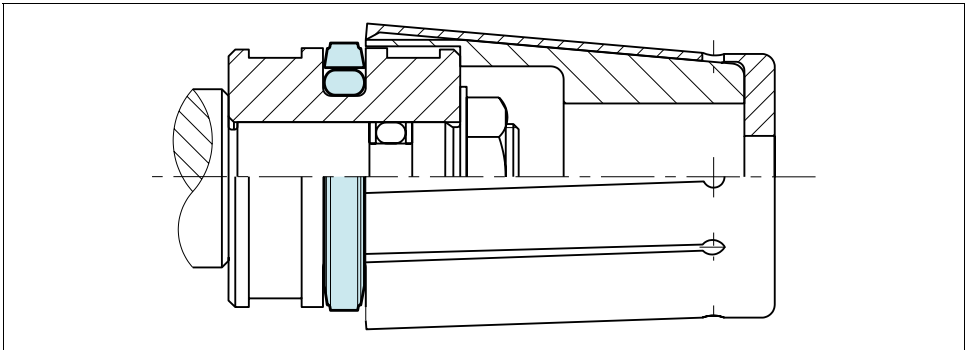

Figure 7 Sealing element after snapping into the groove

Piston Seals

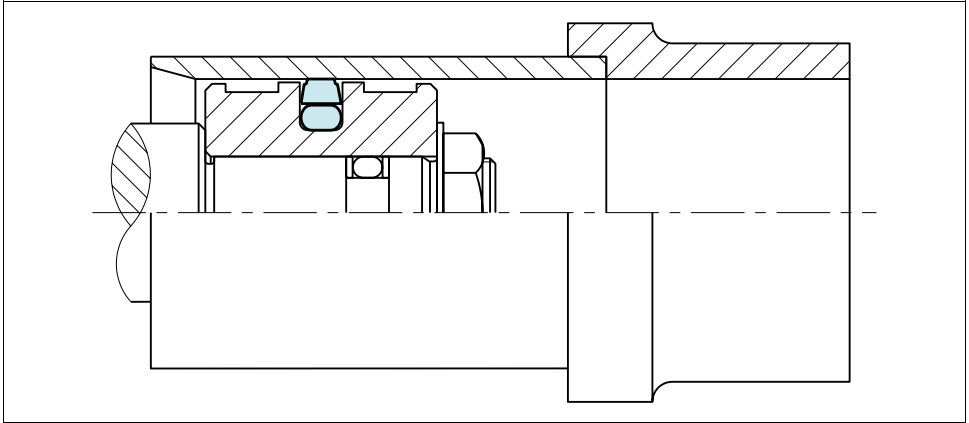

Figure 8 Sizing the sealing element with sizing sleeve

Installation of Turcon® Double Delta®

Installation in closed grooves is possible from 8 mm (.315 inches) bore diameter. For diameters smaller than 50 mm (1.968 inches) a loading mandrel (Fig. 9) is recommended. After installation the seal must be calibrated and this may be done with the lead-in chamfer of the cylinder tube or by means of a separate calibration sleeve.

- Turcon® piston seals can be installed more easily by heating to approx. 80°C to 100°C (176°F to 212°F) (expanding and then shrinking back to the original form).

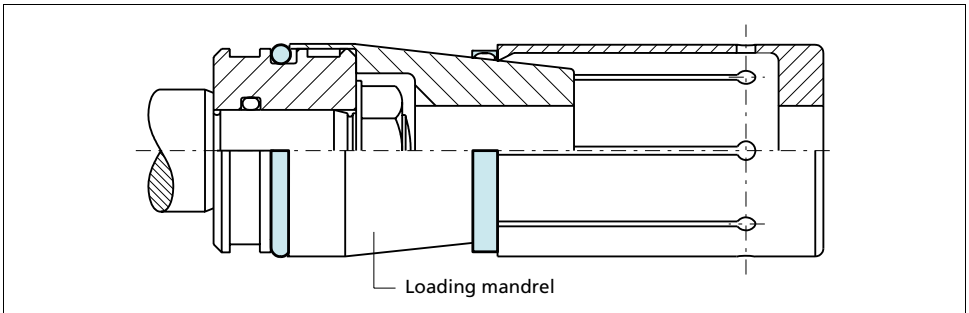

Figure 9 Installation in a closed groove

Piston Seals

Installation of Spring-Energized Seals

Turcon® Variseal® seals should preferably be installed in split grooves. Installation in half-open grooves is possible with a snap fitting. Figure 10 shows the design of the groove.

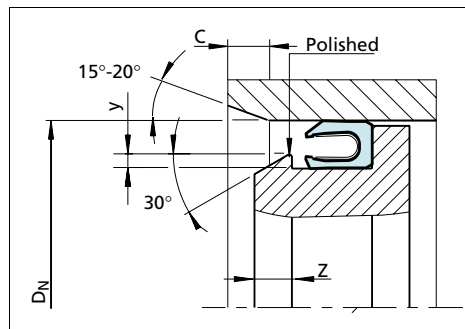

Figure 10 Installation in a half-open groove

Table VI Installation in Half-Open Grooves

Series No.	D _N min.	Y min.	C min.	Z min.
PVAA	.236	.016	.158	.098
PVAB	.393	.023	.197	.138
PVAC	.629	.027	.197	.138
PVAD	1.102	.031	.295	.178
PVAE	1.772	.035	.472	.295
PVAF	2.559	.059	.472	.295

For further details, see chapter "Turcon® Variseal®"

In exceptional cases or with existing designs, an installation in closed grooves is also possible. The details in Table VII should be regarded as guide values for installation.

Table VII Installation in closed grooves

Series No.	D _N min.
PVAA	1.378
PVAB	1.968
PVAC	2.756
PVAD	4.134
PVAE	5.511
PVAF	8.661

Installation of the Compact Seal

The Compact Seal can be installed in one-piece or split pistons. On one-piece pistons, the inner rubber-elastic sealing element is first installed in the middle of the groove diameter by expanding over the piston. Then the cut back-up ring is fitted on both sides of the sealing element and the two cut guide rings are installed.

On split pistons the individual parts are installed in the following order: guide ring, back-up ring, sealing element, back-up ring, guide ring.

Before installation all seal parts, including piston and cylinder, should be oiled or greased.

Piston Seals

ZURCON[®] WYNSEAL

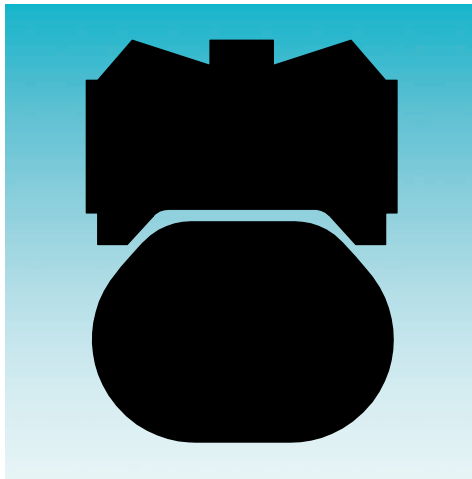

- Double-Acting -
- O-Ring-Energized Zurcon[®] Slipper Seal -

- Material -
- Zurcon[®] -





■ Zurcon® Wynseal

Description

The Zurcon® Wynseal is a double-acting seal consisting of a special polyurethane seal ring and an O-Ring as energizing element (Figure 11).

The unique characteristic of the seal is the special design of the seal edge profile. Two external seal edges act as a primary seal for pressures from both sides and prevent any build-up of hydrodynamic pressure over the seal profile and the risk of the blow-by effect. The central back-up and sealing bulge increases the sealing effect *. Grooves are provided on both sides on the plane surfaces to provide activation of the energizing O-Ring. These ensure direct pressure loading of the seal under all operating conditions.

Since the installation groove is identical to that for the Turcon® Glyd Ring®, the seal is ideal for the standardization of cylinder construction if efficient and low cost seal elements are demanded in large quantities and the cylinder can be adapted to meet different operating conditions.

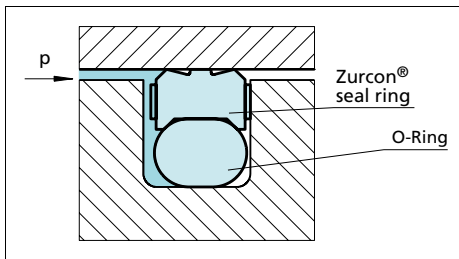

Figure 11 Zurcon® Wynseal

Advantages

- High static and dynamic sealing effect
- High abrasion resistance
- Simple groove design, one-piece piston possible
- Suitable for grooves to ISO 7425, Part 1

* Because of cross-sectional area constraints, PW10 and PW11 cross sections do not have the center support buldge.

Application Examples

The Zurcon® Wynseal is the recommended element for double-acting pistons of hydraulic components in various sectors such as:

- Machine tools
- Forklifts & handling machinery
- Agriculture
- Industrial hydraulic light to medium duty

Technical Data

Pressure:	Up to 3,600 psi (25 MPa)	(Z20N)
Velocity:	Up to 1.65 ft/s (0.5 m/s)	
Temperature:	-31°F to +230°F (-35°C to + 110°C)	
Media:	Mineral oil-based hydraulic fluids	

Important Note:

The above data are maximum values and cannot be used at the same time. e.g. the maximum operating speed depends on material type, pressure, temperature and gap value. Temperature range also dependent on medium.

Materials

Standard Materials:

Seal ring:	Zurcon® Z20, 93 Shore A
O-Ring:	NBR 70 Shore A



■ Installation Recommendation (Inch Piston Series)

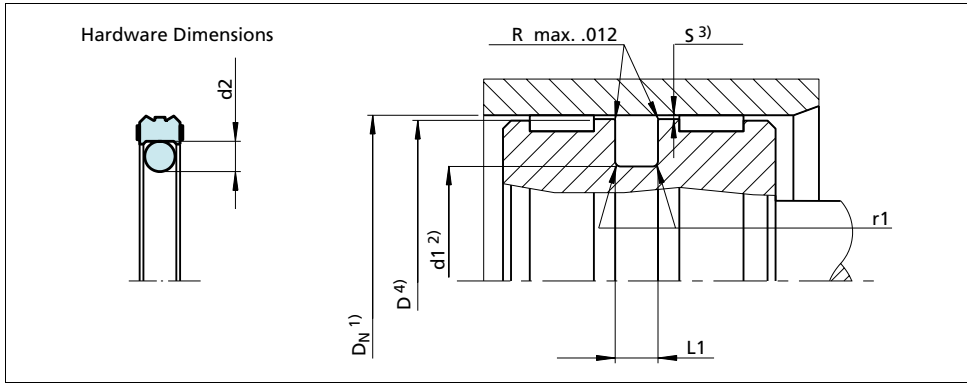

Figure 12 Installation drawing

- 1) Tolerances used are per ISO-286; ISO System of Limits and Fits. The tolerances are converted from metric and rounded to the nearest three place decimal.
- 2) The groove diameter h9 tolerance is recommended per ISO-286; ISO System of Limits and Fits. The tolerances are converted from metric and rounded to the nearest three place decimal.
- 3) The clearance stated as S in the above table are for when the seal is specified with Slydring® bearings. When not incorporating Slydring® bearings, the radial clearance should be reduced.
- 4) To determine minimum piston diameter D, subtract the diametral clearance (2 x S) from maximum bore diameter DN.
- 5) Consult your Trelleborg Sealing Solutions sales office for diameters that exceed those listed in the above table.

Table VIII Installation recommendation

Cross-Section Series	Bore Diameter	Groove Diameter	Groove Width	Radius	O-Ring Cross Section
	DN H9	d1 H9	L +.008/-0.00	r1	
PW10	.375 - .563	DN - .193	.087	.015	.070
PW11	.563 - 1.563	DN - .295	.126	.025	.103
PW12	1.563 - 3.125	DN - .433	.165	.025	.139
PW13	3.125 - 5.250	DN - .610	.248	.035	.210
PW14	5.250 - 12.500	DN - .827	.319	.035	.275
PW15	12.500 - 26.000	DN - .965	.319	.035	.275





Ordering example

Wynseal for ISO groove
 Bore diameter: $D_N = 3.000$ inches
 Series No. PW12
 TSS Part No. PW1203000 (from Table IX)
 Seal ring
 Material code: Z20
 O-Ring material code: N
 Set code: Z20N

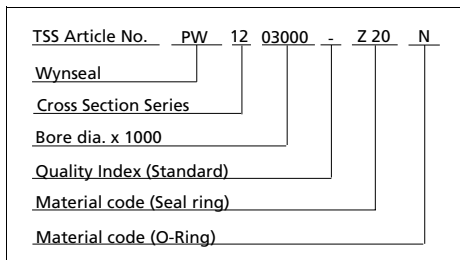

Table IX Installation dimensions / TSS Part No.

Bore Diameter	Groove Diameter	Groove Width	TSS Part No.
D_N H9	D_1 h9	$L_1 +.010$	
1.000	.705	.126	PW1101000
1.125	.830	.126	PW1101125
1.250	.955	.126	PW1101250
1.375	1.080	.126	PW1101375
1.500	1.205	.126	PW1101500
1.625	1.192	.165	PW1201625
1.750	1.317	.165	PW1201750
1.875	1.442	.165	PW1201875
2.000	1.567	.165	PW1202000
2.125	1.692	.165	PW1202125
2.250	1.817	.165	PW1202250
2.375	1.942	.165	PW1202375
2.500	2.067	.165	PW1202500
2.750	2.317	.165	PW1202750
3.000	2.567	.165	PW1203000
3.250	2.640	.248	PW1303250
3.500	2.890	.248	PW1303500
3.750	3.140	.248	PW1303750
4.000	3.390	.248	PW1304000
4.250	3.640	.248	PW1304250
4.500	3.890	.248	PW1304500
4.750	4.140	.248	PW1304750
5.000	4.390	.248	PW1305000
5.250	4.640	.248	PW1305250
5.500	4.673	.319	PW1405500
5.750	4.923	.319	PW1405750
6.000	5.173	.319	PW1406000

Bore Diameter	Groove Diameter	Groove Width	TSS Part No.
D_N H9	D_1 h9	$L_1 +.010$	
6.500	5.673	.319	PW1406500
7.000	6.173	.319	PW1407000
7.500	6.673	.319	PW1407500
8.000	7.173	.319	PW1408000
8.500	7.673	.319	PW1408500
9.000	8.173	.319	PW1409000
9.500	8.673	.319	PW1409500
10.000	9.173	.319	PW1410000
10.500	9.673	.319	PW1410500
11.000	10.173	.319	PW1411000
11.500	10.673	.319	PW1411500
12.000	11.173	.319	PW1412000
12.500	11.673	.319	PW1412500
13.000	12.035	.319	PW1513000
13.500	12.535	.319	PW1513500
14.000	13.035	.319	PW1514000
14.500	13.535	.319	PW1514500
15.000	14.035	.319	PW1515000
15.500	14.535	.319	PW1515500
16.000	15.035	.319	PW1516000
16.500	15.535	.319	PW1516500
17.000	16.035	.319	PW1517000
17.500	16.535	.319	PW1517500
18.000	17.035	.319	PW1518000
18.500	17.535	.319	PW1518500
19.000	18.035	.319	PW1519000
19.500	18.535	.319	PW1519500



Bore Diameter	Groove Diameter	Groove Width	TSS Part No.
D_N H9	D_1 h9	$L_1 +.010$	
20.000	19.035	.319	PW1520000

The sizes listed in **bold** font are preferred sizes (more likely to be available for immediate shipment). Other dimensions and all intermediate sizes up to 20 inches (509 mm) diameter can be supplied.

TURCON[®] GLYD RING[®] T

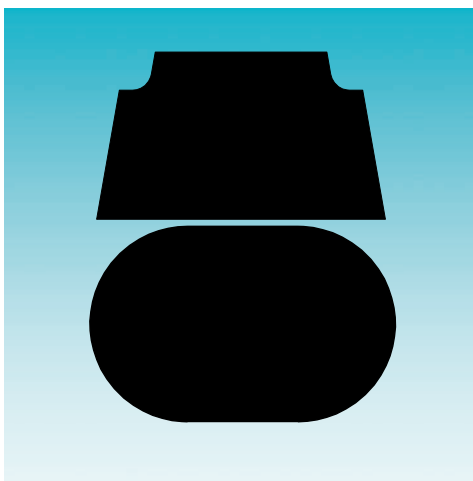

- Double-Acting -
- O-Ring-Energized Turcon[®] Slipper Seal -

- Material -
- Turcon[®], Zurcon[®] and Elastomer -





■ Turcon® Glyd Ring® T*

Description

The Turcon® Glyd Ring® T is a further technical development of the Turcon® Glyd Ring® seal, which has been successfully used for decades. It is fully interchangeable with the earlier Glyd Ring® seals in all new applications. The Glyd Ring® T meets all the market demands for a function-specific sealing solution, observing economic and ecological aspects.

The benefits of the patented seal concept are provided by the innovative functional principle of the trapezoidal profile cross-section.

Both lateral profile flanks are inclined so that the seal profile tapers towards the seal surface. The profile can thus retain the robust and compact form typical of piston seals without losing any of the flexibility required to achieve a pressure-related maximum compression (Figure 13).

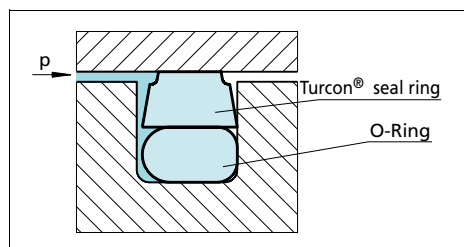

Figure 13 Turcon® Glyd Ring® T

The edge angle created by the special Glyd Ring® T cross-sectional form permits an additional degree of freedom and enables a slight tilting movement of the seal. The maximum compression is always shifted towards the area of the seal edge directly exposed to the pressure. On the low-pressure edge of the seal the Glyd Ring® T exhibits only zones with neutral strains without compressive or shearing loads, effectively reducing the danger of gap extrusion. The resulting benefits for the user can be seen in the following list.

Advantages

The benefits offered by the Glyd Ring® remain and are now complemented by these further advantages:

- Very good static leak-tightness
- Increased clearance possible (approx. +50%), depending on the operating conditions
- Due to the larger extrusion gap, safe use even with soiled media
- Low friction, no stick-slip effect

- Simple groove design, one-piece pistons possible
- Adaptable to the operating conditions due to a wide range of possible materials (Turcon®, Zurcon®)
- Suitable for new environmentally safe hydraulic fluids
- Available for all cylinder diameters up to 106 inches (2,700 mm)

Application Examples

The Turcon® Glyd Ring® T is the recommended sealing element for double-acting pistons of hydraulic components such as:

- Injection molding machines
- Machine tools
- Presses
- Excavators
- Forklifts & handling machinery
- Agriculture machinery
- Valves for hydraulic & pneumatic circuits

It is particularly recommended for heavy duty and large diameter applications.

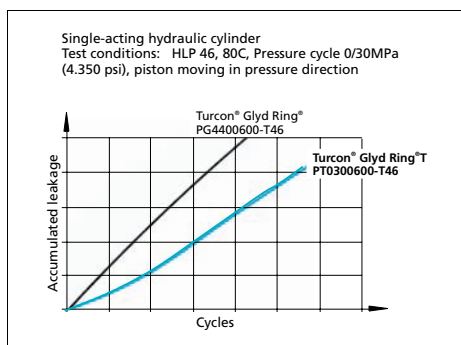

Figure 14 Dynamic leakage Turcon® Glyd Ring® T/ Turcon® Glyd Ring® as single-acting piston seal



Turcon® Glyd Ring® T

Technical Data

Operating conditions

Pressure:	Up to 11,600 psi (80 MPa)
Velocity:	Up to 50 ft/s (15 m/s)
Temperature:	-49°F to +392°F (-45°C to +200°C *) (depending on O-Ring material)
Media:	Mineral oil-based hydraulic fluids, barely flammable hydraulic fluids, environmentally safe hydraulic fluids (bio-oils), water, air and others, depending on the O-Ring material (see Table X)
Clearance:	The maximum permissible radial clearance s_{max} is shown in Table XI, as a function of the operating pressure and functional diameter.

Important Note:

The above data are maximum values and cannot be used at the same time. e.g. the maximum operating speed depends on material type, pressure, temperature and gap value. Temperature range also dependent on medium.

*) In the case of unpressurized applications in temperatures below 32 °F (0 °C) please contact our application engineers for assistance!

Materials

Standard Application:

- For hydraulic components with reciprocating movement in mineral oils containing zinc or medium with good lubricating performance

Seal ring:	Turcon® T46
Energizer:	O-Ring NBR 70 shore A or FKM 70 Shore A depending on the temperature
Set reference:	T46N or T46V

Special Application:

- Non-lubricating fluids or pneumatic applications require self-lubricating sealing materials. Therefore we recommend:

Seal ring:	Turcon® T40
Energizer:	O-Ring NBR 70 Shore A or FKM 70 Shore A depending on the temperature
Set reference:	T40N or T40V

- If rougher surface finish must be sealed, we recommend:

Seal ring:	Zurcon® Z51
Energizer:	O-Ring NBR 70 Shore A
Set reference:	Z51N



Table X Turcon® and Zurcon® Materials for Glyd Ring® T

Material, Applications, Properties	Code	O-Ring Material	Code	O-Ring Operating Temp.* °F	Mating Surface Material	PSI Max.
Turcon® T46 Standard material for hydraulics, high compressive strength, good sliding and wear properties, good extrusion resistance, BAM tested. Bronze-filled Color: grayish to dark brown	T46	NBR - 70 Shore A	N	-22 to +212	Steel tubes Steel, hardened Cast iron	8,700
		NBR - Low temp. 70 Shore A	T	-49 to +176		
		FKM - 70 Shore A	V	-14 to +392		
Turcon® T40 For all lubricating and non-lubricating hydraulic fluids, hydraulic oils without zinc, water hydraulic, soft mating surfaces, good extrusion resistance. Surface texture not suitable for gases. High carbon fiber-filled Color: gray	T40	NBR - 70 Shore A	N	-22 to +212	Steel Cast iron Stainless steel Aluminium Bronze Alloys	3,625
		NBR - Low temp. 70 Shore A	T	-49 to +176		
		FKM - 70 Shore A	V	-14 to +392		
		EPDM - 70 Shore A	E**	-49 to +293		
Zurcon® Z51*** For lubricating hydraulic fluids, high abrasion resistance, high extrusion resistance , limited chemical resistance. Cast polyurethane Color: yellow to light-brown	Z51	NBR - 70 Shore A	N	-22 to +212	Steel Steel, hardened Cast iron Ceramic coating Stainless steel	11,600
		NBR - Low temp. 70 Shore A	T	-49 to +176		

* The O-Ring operation temperature is only valid in mineral hydraulic oil. ** Material not suitable for mineral oils.

*** max. Ø 90 inches (2,300 mm) BAM: Tested by "Bundes Anstalt Materialprüfung, Germany".

Highlighted materials are standard.



■ Installation Recommendation (Inch Piston Series)

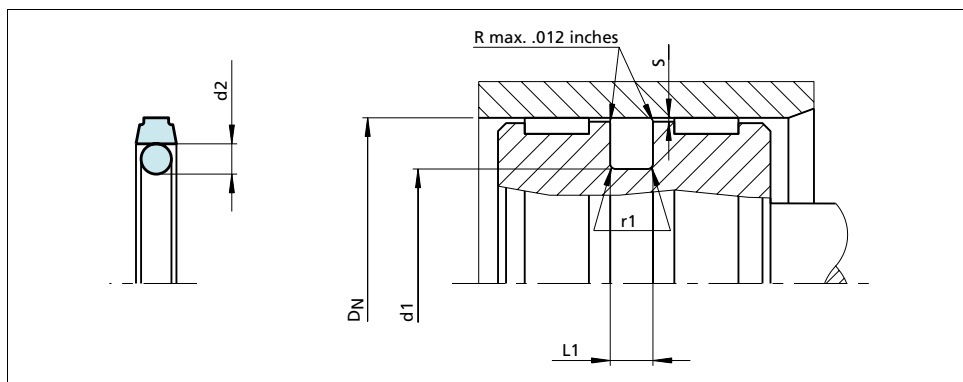

Figure 15 Installation drawing

Table XI Installation Recommendation

TSS Series No.	Bore Diameter			Groove Diam.	Groove Width	Rad.	Radial Clearance			O-Ring Cross-Sec.
	D_N H9						S max.*			
	Standard Application	Light Application	Heavy Duty Application				d_1 h9	L_1 +.008	r_1	
PT10	.312 - .562	.625 - 1.500	-	D_N - .193	.087	.015	.020	.012	.008	.070
PT11	.562 - 1.563	1.563 - 3.125	-	D_N - .295	.126	.025	.024	.016	.008	.103
PT12	1.563 - 3.125	3.125 - 5.250	.560 - 1.563	D_N - .433	.165	.025	.024	.016	.008	.139
PT13	3.125 - 5.250	5.250 - 12.500	1.563 - 3.125	D_N - .610	.248	.035	.031	.020	.012	.210
PT14	5.250 - 12.500	12.500 - 26.000	3.125 - 5.250	D_N - .827	.319	.035	.031	.020	.012	.275
PT15	12.500 - 26.000	-	5.250 - 12.500	D_N - .965	.319	.035	.035	.020	.016	.275

* At pressures > 40 MPa (5,800 psi) use diameter tolerance H8/f8 (bore/piston) in area of the seal. The radial clearance is valid for material Turcon® T46 at +140°F (+60°C).



Ordering example

Turcon® Glyd Ring® T, complete with O-Ring, standard application, series PT12 (from Table XI)

Bore diameter: $D_N = 3.000$ inches

TSS Part No.: PT1203000 (from Table XII)

Select the material from Table X. The corresponding code numbers are appended to the TSS Part No. (from Table XII). Together they form the TSS Article No.

For all intermediate sizes not shown in Table XII, the TSS Article No. can be determined from the example opposite.

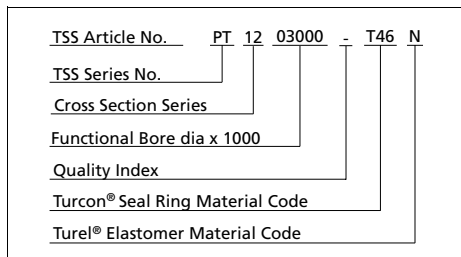

*** For diameters ≥ 100.000 inches please consult your Trelleborg Sealing Solutions sales office for special part no.

Table XII Installation Dimensions / TSS Part No.

Bore Diameter	Groove Diameter	Groove Width	TSS Part No.
D_N H9	d_1 h9	$L_1 +.010$	
.500	.307	.087	PT1000500
.563	.370	.087	PT1000563
.625	.330	.126	PT1100625
.688	.393	.126	PT1100688
.750	.455	.126	PT1100750
.813	.518	.126	PT1100813
.875	.580	.126	PT1100875
.938	.643	.126	PT1100938
1.000	.705	.126	PT1101000
1.063	.768	.126	PT1101063
1.125	.830	.126	PT1101125
1.188	.893	.126	PT1101188
1.250	.955	.126	PT1101250
1.313	1.018	.126	PT1101313
1.375	1.080	.126	PT1101375
1.438	1.143	.126	PT1101438
1.500	1.205	.126	PT1101500
1.563	1.268	.126	PT1101563
1.625	1.192	.165	PT1201625
1.688	1.255	.165	PT1201688
1.750	1.317	.165	PT1201750
1.813	1.380	.165	PT1201813
1.875	1.442	.165	PT1201875
1.938	1.505	.165	PT1201938

Bore Diameter	Groove Diameter	Groove Width	TSS Part No.
D_N H9	d_1 h9	$L_1 +.010$	
2.000	1.567	.165	PT1202000
2.125	1.692	.165	PT1202125
2.250	1.817	.165	PT1202250
2.375	1.942	.165	PT1202375
2.500	2.067	.165	PT1202500
2.625	2.193	.165	PT1202625
2.750	2.317	.165	PT1202750
2.875	2.442	.165	PT1202875
3.000	2.567	.165	PT1203000
3.125	2.692	.165	PT1203125
3.250	2.640	.248	PT1303250
3.375	2.765	.248	PT1303375
3.500	2.890	.248	PT1303500
3.625	3.015	.248	PT1303625
3.750	3.140	.248	PT1303750
3.875	3.265	.248	PT1303875
4.000	3.390	.248	PT1304000
4.125	3.515	.248	PT1304125
4.250	3.640	.248	PT1304250
4.375	3.765	.248	PT1304375
4.500	3.890	.248	PT1304500
4.625	4.015	.248	PT1304625
4.750	4.140	.248	PT1304750
4.875	4.265	.248	PT1304875



Turcon® Glyd Ring® T

Bore Diameter	Groove Diameter	Groove Width	TSS Part No.
D_N H9	d_1 h9	L_1 +.010	
5.000	4.390	.248	PT1305000
5.125	4.515	.248	PT1305125
5.250	4.640	.248	PT1305250
5.375	4.548	.319	PT1405375
5.500	4.673	.319	PT1405500
5.625	4.798	.319	PT1405625
5.750	4.923	.319	PT1405750
6.000	5.173	.319	PT1406000
6.250	5.423	.319	PT1406250
6.500	5.673	.319	PT1406500
6.750	5.923	.319	PT1406750
7.000	6.173	.319	PT1407000
7.250	6.423	.319	PT1407250
7.500	6.673	.319	PT1407500
7.750	6.923	.319	PT1407750
8.000	7.173	.319	PT1408000
8.250	7.423	.319	PT1408250
8.500	7.673	.319	PT1408500
8.750	7.923	.319	PT1408750
9.000	8.173	.319	PT1409000
9.250	8.423	.319	PT1409250
9.500	8.673	.319	PT1409500
9.750	8.923	.319	PT1409750
10.000	9.173	.319	PT1410000
10.500	9.673	.319	PT1410500
11.000	10.173	.319	PT1411000
11.500	10.673	.319	PT1411500
12.000	11.173	.319	PT1412000
12.500	11.673	.319	PT1412500
13.000	12.035	.319	PT1513000
13.500	12.535	.319	PT1513500
14.000	13.035	.319	PT1514000
14.500	13.535	.319	PT1514500
15.000	14.035	.319	PT1515000
15.500	14.535	.319	PT1515500
16.000	15.035	.319	PT1516000

Bore Diameter	Groove Diameter	Groove Width	TSS Part No.
D_N H9	d_1 h9	L_1 +.010	
16.500	15.535	.319	PT1516500
17.000	16.035	.319	PT1517000
17.500	16.535	.319	PT1517500
18.000	17.035	.319	PT1518000
18.500	17.535	.319	PT1518500
19.000	18.035	.319	PT1519000
19.500	18.535	.319	PT1519500
20.000	19.035	.319	PT1520000

The sizes listed in **bold** font are preferred sizes (more likely to be available for immediate shipment). Other dimensions and all intermediate sizes up to 106 inches (2700mm) diameter can be supplied.

ZURCON[®] GLYD RING[®] P (ISO)

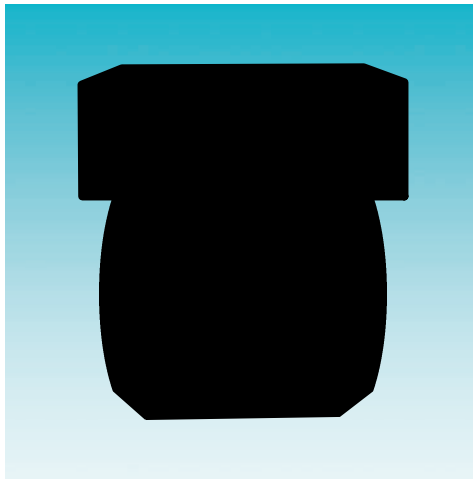

- Double-Acting -
- Elastomer-Energized Zurcon[®] Slipper Seal -

- Materials -
- Zurcon[®] -





■ Zurcon® Glyd Ring® P (ISO)

Description

The double-acting Zurcon® Glyd Ring® P is a combination of a Zurcon®-based slipper seal with a step cut and an energizing rectangular elastomeric ring. It is produced with an interference fit at closed step cut which together with the squeeze of the rectangular energizer ring ensures a good sealing effect even at low pressure.

At higher system pressures, the rectangular ring is energized by the fluid, pushing the Zurcon® Glyd Ring® P against the sealing face with increased force. At high peak pressures, the Zurcon® step cut seal ring can follow ballooning of the tube without losing the sealability.

Due to the Zurcon® high strength plastic material, two times bigger extrusion gaps are possible compared with Turcon® materials. The step cut in the ring is necessary for installation in closed grooves and for the flexibility of the seal ring due to the high stiffness of the material.

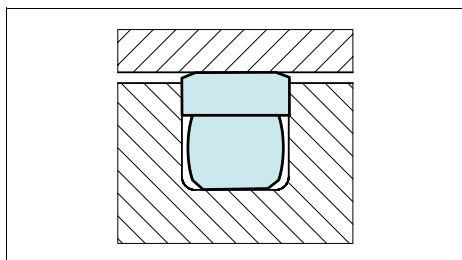

Figure 16 Zurcon® Glyd Ring® P

Step Cut

For easy installation on the piston and for the flexibility of the seal ring a precision step cut is produced by special tool technology.

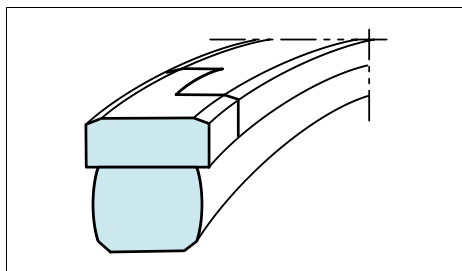

Figure 17 Step cut on Zurcon® Glyd Ring® P

Advantages

- Easy installation on piston without special tools
- Due to large extrusion gap, safe use even with soiled media
- Installation grooves acc. to ISO 7425/1
- Simple groove design, one piece piston possible
- Increased clearance compared to Turcon® Glyd Ring® seals (approx. +50%), depending on operation conditions
- Resistant against shock loads
- High wear resistant material ensures long service life

Application Examples

- Telescopic cylinders
- Construction machinery, e.g. excavators
- Truck cranes
- Fork lifts

It is particularly recommended for heavy duty applications

Technical Data

Operating conditions:

The Zurcon® Glyd Ring® P is recommended for reciprocating (with a length of stroke at least twice the groove width) movements where the dimensional gap between piston and tube is as big as possible or where high pressure peaks occur during operation.

Pressure: 7,250 psi (50 MPa) standard
14,500 psi (100 MPa) pressure peak

Velocity: Up to 3.3 ft/s (1 m/s)

Temperature: -22°F to +230°F (-30°C to +110°C)
-40°F to +212°F (-40°C to +100°C)
-5°F to +284°F (-15°C to +140°C)

Media: mineral oil-based hydraulic fluids

Important Note:

The above data are maximum values and cannot be used at the same time. e.g. the maximum operating speed depends on material type, pressure, temperature and gap value. Temperature range also dependent on medium.



Materials

Standard Application:

- For hydraulic components in mineral oils or media with good lubricating performance

Seal ring: Zurcon® Z66

Energizer: Rectangular ring in NBR 70 shore A, code N

Set reference: Z66N

Low Temperature Application:

Seal ring: Zurcon® Z66

Energizer: Rectangular ring in low temp. NBR 70 shore A, code T

Set reference: Z66T

High Temperature Application:

Seal ring: Zurcon® Z66

Energizer: Rectangular ring in FKM 70 shore A, code V

Set reference: Z66V



■ Installation Recommendation (Inch Piston Series)

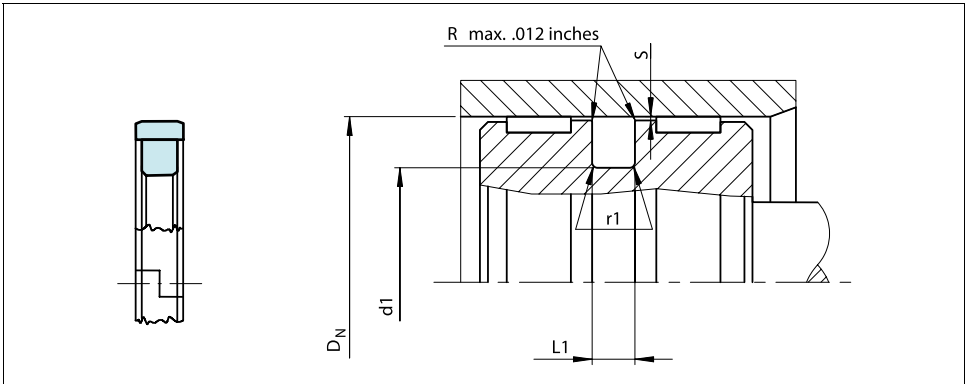

Figure 19 Installation drawing

Table XIII Installation dimensions/TSS Part No.

TSS Series No.	Groove Diameter	Groove Width	Radius	Radial Clearance S max.
	d_1 h9	$L_1 + .008$	r_1	
PGP2	$D_n - .433$.165	.020	.014
PGP3	$D_n - .610$.248	.035	.020
PGP4	$D_n - .827$.319	.035	.024

Ordering Example

Zurcon® Glyd Ring® P for ISO groove
 TSS Series No.: PGP4
 TSS Part No.: PGP200762
 TSS seal ring material code: Z66
 Energizer material code: N
 Set code: Z66N

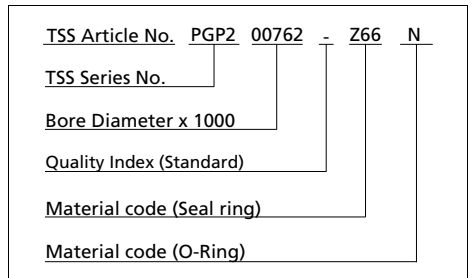

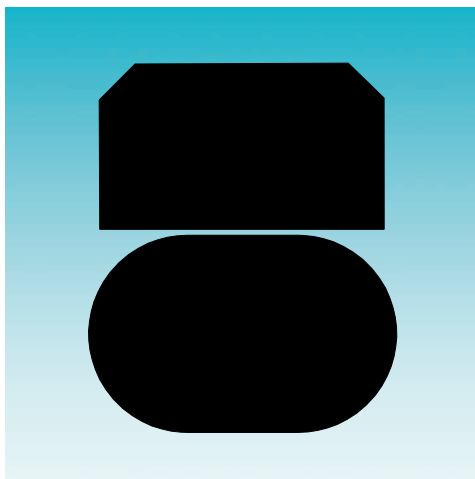

Table XIV Installation Dimensions / TSS Article No.

Bore Diameter	Groove Diameter	Groove Width	TSS Article No.
D_N H9	d_1 h9	L_1 +.010	
1.750	1.317	.165	PGP200445-Z66N
2.000	1.567	.165	PGP200508-Z66N
2.250	1.817	.165	PGP200572-Z66N
2.500	2.067	.165	PGP200635-Z66N
2.750	2.317	.165	PGP200700-Z66N
3.000	2.567	.165	PGP200762-Z66N
3.250	2.640	.248	PGP300826-Z66N
3.500	2.890	.248	PGP300889-Z66N
3.750	3.140	.248	PGP300953-Z66N
4.000	3.390	.248	PGP301016-Z66N
4.250	3.640	.248	PGP301080-Z66N
4.500	3.890	.248	PGP301143-Z66N
4.750	4.140	.248	PGP301207-Z66N
5.000	4.390	.248	PGP301270-Z66N
5.250	4.640	.248	PGP301334-Z66N
5.500	4.673	.319	PGP401397-Z66N
5.750	4.923	.319	PGP401461-Z66N
6.000	5.173	.319	PGP401524-Z66N
6.500	5.673	.319	PGP401651-Z66N
7.000	6.173	.319	PGP401778-Z66N
7.500	6.673	.319	PGP401905-Z66N
8.000	7.173	.319	PGP402032-Z66N
8.500	7.673	.319	PGP402159-Z66N
9.000	8.173	.319	PGP402286-Z66N
10.000	9.173	.319	PGP402540-Z66N

The sizes listed in **bold** font are preferred sizes (more likely to be available for immediate shipment). Other dimensions and all intermediate sizes up to 10 inches (254mm) diameter can be supplied.

TURCON[®] GLYD RING[®]



- Double-Acting -
- O-Ring-Energized Turcon[®] Slipper Seal -

- Material -
- Turcon[®] or Zurcon[®] -





■ Turcon® Glyd Ring®

Description

Successfully used for decades, the Turcon® Glyd Ring® is a very effective and reliable low frictional seal. It is particularly suitable as a piston seal in both high and low pressure systems.

The double-acting Turcon® Glyd Ring® is a combination of a Turcon®-based slipper seal and an energizing O-Ring. It is produced with an interference fit which together with the squeeze of the O-Ring ensures a good sealing effect even at low pressure. At higher system pressures, the O-Ring is energized by the fluid, pushing the Turcon® Glyd Ring® against the sealing face with increased force.

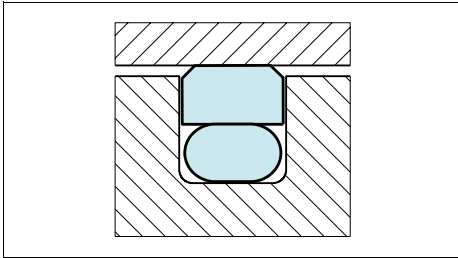

Figure 23 Turcon® Glyd Ring®

The geometry of the Turcon® Glyd Ring® ensures a good static sealing and allows the lubricating hydrodynamic oil film to be built under the seal in reciprocating applications.

Notches

To assure that a rapid energizing of the seal takes place at sudden changes of pressure and direction of motion, radial notches are machined on both sides of the seal.

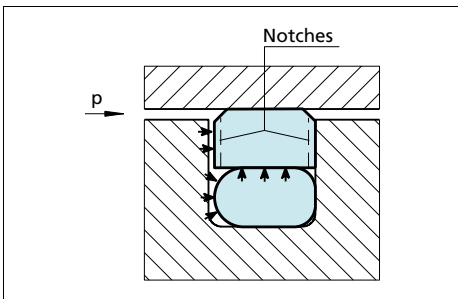

Figure 24 Turcon® Glyd Ring® with notches

Notches are available and recommended on the Glyd Ring® series by changing the third digit to an "N". See ordering example.

Advantages

- No stick-slip effect when starting for smooth operation
- Minimum static and dynamic friction coefficient for a minimum energy loss and operating temperature
- Suitable for non-lubricating fluids depending on seal material for optimum design flexibility
- High wear resistance ensures long service life
- No adhesive effect to the mating surface during long period of inactivity or storage
- Suitable for most hydraulic fluids in relation to most modern hardware materials and surface finishes depending on material selected
- Suitable for new environmentally safe hydraulic fluids
- Available for all cylinder diameters up to 106 inches (2,700 mm)

Application Examples

Over several decades the Turcon® Glyd Ring® has been successfully implemented as a double-acting piston seal for hydraulic components. Examples include:

- Injection molding machines
- Machine tools
- Presses
- Excavators
- Forklifts & handling machinery
- Agriculture equipment
- Valves for hydraulic & pneumatic circuits



Technical Data

Operating conditions:

The Turcon® Glyd Ring® is recommended for reciprocating (with a length of stroke at least twice the groove width) and helical movements.

Pressure:	Up to 11,600 psi (80MPa)
Velocity:	Up to 50 ft/s (15m/s)
Frequency:	Up to 5 Hz.
Temperature:	-49°F to +392°F (-45°C to +200°C *) (depending on O-Ring material)
Media:	Mineral oil-based hydraulic fluids, barely flammable hydraulic fluids, environmentally safe hydraulic fluids (biological degradable oils), water, air and others. This depends on the O-Ring material compatibility.
Clearance:	The maximum permissible radial clearance sMax is shown in the Table XVIII as a function of the operating pressure and functional diameter.

Important Note:

The above data are maximum values and cannot be used at the same time. e.g. the maximum operating speed depends on material type, pressure, temperature and gap value. Temperature range also dependent on medium.

*) In the case of unpressurized applications in temperatures below 32 °F (0 °C) please contact our application engineers for assistance!

Materials

Standard Applications:

- For hydraulic components in mineral oils containing zinc or medium with good lubricating performance

Seal ring:	Turcon® T 46
Energizer:	O-Ring NBR 70 shore A or FKM 70 Shore A depending on the temperature
Set reference:	T46N or T46V

Special Applications:

- Short stroke movements, non-lubricating fluids or pneumatic applications require self-lubricating sealing materials. Therefore we recommend:

Seal ring:	Turcon® T29
Energizer:	O-Ring NBR 70 Shore A or FKM 70 Shore A depending on the temperature
Set reference:	T29N or T29V
- If low friction coefficient is required, we recommend:	
Seal ring:	Turcon® T 05
Energizer:	O-Ring NBR 70 Shore A or FKM 70 Shore A depending on the temperature. For special requirements other elastomers are available on request
Set reference:	T05N or T05V
- If rougher surface finish must be sealed, we recommend:	
Seal ring:	Zurcon® Z51
Energizer:	O-Ring NBR 70 Shore A
Set reference:	Z51N





Table XVII Turcon® and Zurcon® Materials for Glyd Ring®

Material, Applications, Properties	Code	O-Ring Material	Code	O-Ring Operating Temp.* °F	Mating Surface Material	PSI max.
Turcon® T46 Standard material for hydraulics, high compressive strength, good sliding and wear properties, good extrusion resistance, BAM tested. Bronze-filled Color: grayish to dark brown	T46	NBR - 70 Shore A	N	-22 to +212	Steel tubes Steel, hardened Cast iron	8,700
		NBR - Low temp. 70 Shore A	T	-49 to +176		
		FKM - 70 Shore A	V	-14 to +392		
Turcon® T08 Very high compressive strength, very good extrusion resistance. High bronze-filled Color: light to dark brown	T08	NBR - 70 Shore A	N	-22 to +212	Steel tubes Steel, hardened Cast iron	11,600
		NBR - Low temp. 70 Shore A	T	-49 to +176		
		FKM - 70 Shore A	V	-14 to +392		
Turcon® T40 For all lubricating and non-lubricating hydraulic fluids, water hydraulic, soft mating surfaces. Surface texture not suitable for gases. Carbon fiber-filled Color: gray	T40	NBR - 70 Shore A	N	-22 to +212	Steel Cast iron Stainless steel Aluminium Bronze Alloys	3,625
		NBR - Low temp. 70 Shore A	T	-49 to +176		
		FKM - 70 Shore A	V	-14 to +392		
		EPDM-70 Shore A	E**	-49 to +293		
Turcon® T29 For all lubricating and non-lubricating hydraulic fluids, hydraulic oils without zinc, soft mating surfaces, good extrusion resistance. Surface texture not suitable for gases. High carbon fiber-filled Color: gray	T29	NBR - 70 Shore A	N	-22 to +212	Steel Cast iron Stainless steel Aluminium Bronze	8,700
		NBR - Low temp. 70 Shore A	T	-49 to +176		
		FKM - 70 Shore A	V	-14 to +392		
		EPDM-70 Shore A	E**	-49 to +293		
Turcon® T05 For all lubricating hydraulic fluids, hard mating surfaces, very good sliding properties, low friction. Color: turquoise	T05	NBR - 70 Shore A	N	-22 to +212	Steel tubes Steel, hardened	2,900
		NBR - Low temp. 70 Shore A	T	-49 to +176		
		FKM - 70 Shore A	V	-14 to +392		
Turcon® T42 For all lubricating and non-lubricating hydraulic fluids, good chemical resistance, good dielectric properties. Glass fiber-filled + MoS ₂ Color: gray to blue	T42	NBR - 70 Shore A	N	-22 to +212	Steel tubes Steel, hardened Cast iron	4,350
		NBR - Low temp. 70 Shore A	T	-49 to +176		
		FKM - 70 Shore A	V	-14 to +392		
Turcon® T10 For oil hydraulic and pneumatic, for all lubricating and non-lubricating fluids, high extrusion resistance, good chemical resistance, BAM tested. Carbon, graphite-filled Color: black	T10	NBR - 70 Shore A	N	-22 to +212	Steel Stainless steel	8,700
		NBR - Low temp. 70 Shore A	T	-49 to +176		
		FKM - 70 Shore A	V	-14 to +392		
		EPDM-70 Shore A	E**	-49 to +293		
Zurcon® Z51*** For lubricating hydraulic fluids, high abrasion resistance, high extrusion resistance, limited chemical resistance. Cast polyurethane Color: yellow to light-brown	Z51	NBR - 70 Shore A	N	-22 to +212	Steel Steel, hardened Cast iron Ceramic coating Stainless steel	11,800
		NBR - Low temp. 70 Shore A	T	-49 to +176		
Zurcon® Z80 For lubricating and non-lubricating hydraulic fluids, high abrasion resistance, very good chemical resistance, limited temperature resistance. Ultra high molecular weight polyethylene Color: white to off-white	Z80	NBR - 70 Shore A	N	-22 to +176	Steel Stainless steel Aluminium Bronze Ceramic coating	5,800
		NBR - Low temp. 70 Shore A	T	-49 to +176		

* The O-Ring operation temperature is only valid in mineral hydraulic oil. ** Material not suitable for mineral oils.
*** max. Ø 90 inches (2,300 mm) BAM: Tested by "Bundes Anstalt Materialprüfung, Germany". □ Highlighted materials are standard.



■ Installation Recommendation (Inch Piston Series)

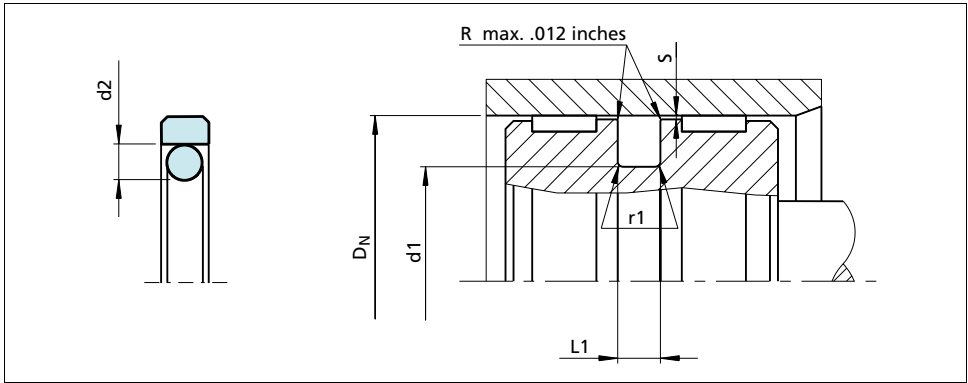

Figure 25 Installation drawing

Table XVIII Installation Dimension

TSS Series No.	Bore Diameter			Groove Diameter	Groove Width	Radius	Radial Clearance			O-Ring Cross-Section
	DN H9						S max.*			
	Standard Application	Light Application	Heavy Duty Application				d ₁ h9	L ₁ +.008	r ₁	
PG00	.312 - .562	.625 - 1.500	-	D _N - .193	.087	.015	.020	.012	.008	.070
PG01	.562 - 1.563	1.563 - 3.125	-	D _N - .295	.126	.025	.024	.016	.008	.103
PG02	1.563 - 3.125	3.125 - 5.250	.562 - 1.563	D _N - .433	.165	.025	.024	.016	.008	.139
PG03	3.125 - 5.250	5.250 - 12.500	1.563 - 3.125	D _N - .610	.248	.035	.031	.020	.012	.210
PG04	5.250 - 12.500	12.500 - 26.000	3.125 - 5.250	D _N - .827	.319	.035	.031	.020	.012	.275
PG05	12.500 - 26.000	-	5.250 - 12.500	D _N - .965	.319	.035	.035	.020	.016	.275

* At pressures > 40 MPa (5,800 psi) use diameter tolerance H8/f8 (bore/piston) in area of the seal.



Ordering Example

Turcon® Glyd Ring®, complete with O-Ring, standard application, Series PG02 (from Table XVIII)

Bore diameter: $D_N = 2.500$ inches
 TSS Part No.: PG0202500 (from Table XIX)

Select the material from Table XVII. The corresponding code numbers are appended to the TSS Part No. Preferred Series (Table XIX).

Together they form the TSS Article Number. The TSS Article Number for all intermediate sizes not shown in Preferred Series (Table XIX) can be determined following the example opposite.

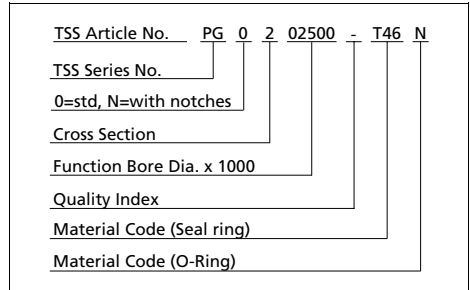

For diameters $D_N \geq 100.000$ inches please consult your Trelleborg Sealing Solutions sales office for custom article no.

Table XIX Installation dimensions / TSS Part No.

Bore Diameter	Groove Diameter	Groove Width	TSS Part No.
D_N H9	d_1 h9	$L_1 +.010$	
.500	.307	.087	PG0000500
.563	.370	.087	PG0000563
.625	.330	.126	PG0100625
.688	.393	.126	PG0100688
.750	.455	.126	PG0100750
.813	.518	.126	PG0100813
.875	.580	.126	PG0100875
.938	.643	.126	PG0100938
1.000	.705	.126	PG0101000
1.063	.768	.126	PG0101063
1.125	.830	.126	PG0101125
1.188	.893	.126	PG0101188
1.250	.955	.126	PG0101250
1.313	1.018	.126	PG0101313
1.375	1.080	.126	PG0101375
1.438	1.143	.126	PG0101438
1.500	1.205	.126	PG0101500
1.563	1.268	.126	PG0101563
1.625	1.192	.165	PG0201625
1.688	1.255	.165	PG0201688
1.750	1.317	.165	PG0201750
1.813	1.380	.165	PG0201813
1.875	1.442	.165	PG0201875
1.938	1.505	.165	PG0201938

Bore Diameter	Groove Diameter	Groove Width	TSS Part No.
D_N H9	d_1 h9	$L_1 +.010$	
2.000	1.567	.165	PG0202000
2.125	1.692	.165	PG0202125
2.250	1.817	.165	PG0202250
2.375	1.942	.165	PG0202375
2.500	2.067	.165	PG0202500
2.626	2.193	.165	PG0202625
2.750	2.317	.165	PG0202750
2.875	2.442	.165	PG0202875
3.000	2.567	.165	PG0203000
3.125	2.692	.165	PG0203125
3.250	2.640	.248	PG0303250
3.375	2.765	.248	PG0303375
3.500	2.890	.248	PG0303500
3.625	3.015	.248	PG0303625
3.750	3.140	.248	PG0303750
3.875	3.265	.248	PG0303875
4.000	3.390	.248	PG0304000
4.125	3.515	.248	PG0304125
4.250	3.640	.248	PG0304250
4.375	3.765	.248	PG0304375
4.500	3.890	.248	PG0304500
4.625	4.015	.248	PG0304625
4.750	4.140	.248	PG0304750
4.875	4.265	.248	PG0304875



Bore Diameter	Groove Diameter	Groove Width	TSS Part No.
D _N H9	d ₁ h9	L ₁ +.010	
5.000	4.390	.248	PG0305000
5.125	4.515	.248	PG0305125
5.250	4.640	.248	PG0305250
5.375	4.548	.319	PG0405375
5.500	4.673	.319	PG0405500
5.625	4.798	.319	PG0405625
5.750	4.923	.319	PG0405750
6.000	5.173	.319	PG0406000
6.250	5.423	.319	PG0406250
6.500	5.673	.319	PG0406500
6.750	5.923	.319	PG0406750
7.000	6.173	.319	PG0407000
7.250	6.423	.319	PG0407250
7.500	6.673	.319	PG0407500
7.750	6.923	.319	PG0407750
8.000	7.173	.319	PG0408000
8.250	7.423	.319	PG0408250
8.500	7.673	.319	PG0408500
8.750	7.923	.319	PG0408750
9.000	8.173	.319	PG0409000
9.250	8.423	.319	PG0409250
9.500	8.673	.319	PG0409500
9.750	8.923	.319	PG0409750
10.000	9.173	.319	PG0410000
10.500	9.673	.319	PG0410500
11.000	10.173	.319	PG0411000
11.500	10.673	.319	PG0411500
12.000	11.173	.319	PG0412000
12.500	11.673	.319	PG0412500
13.000	12.035	.319	PG0513000
13.500	12.535	.319	PG0513500
14.000	13.035	.319	PG0514000
14.500	13.535	.319	PG0514500
15.000	14.035	.319	PG0515000
15.500	14.535	.319	PG0515500
16.000	15.035	.319	PG0516000

Bore Diameter	Groove Diameter	Groove Width	TSS Part No.
D _N H9	d ₁ h9	L ₁ +.010	
16.500	15.535	.319	PG0516500
17.000	16.035	.319	PG0517000
17.500	16.535	.319	PG0517500
18.000	17.035	.319	PG0518000
18.500	17.535	.319	PG0518500
19.000	18.035	.319	PG0519000
19.500	18.535	.319	PG0519500
20.000	19.035	.319	PG0520000

The sizes listed in **bold** font are preferred sizes (more likely to be available for immediate shipment). Other dimensions and all intermediate sizes up to 106 inches (2700mm) diameter can be supplied.



TURCON[®] GLYD RING[®] C



- Double-Acting -
- O-Ring-Energized Turcon[®] Slipper Seal -

- Materials -
- Turcon[®] or Zurcon[®] -





■ Turcon® Glyd Ring® C

Description

Successfully used for decades, the Turcon® Glyd Ring® C is a very effective and reliable low frictional seal. It is particularly suitable as a piston seal in both high and low pressure systems.

The double-acting Turcon® Glyd Ring® C is a combination of a Turcon®-based slipper seal and an energizing O-Ring. It is produced with an interference fit which, together with the squeeze of the O-Ring, ensures a good sealing effect even at low pressure. At higher system pressures, the O-Ring is energized by the fluid, pushing the Turcon® Glyd Ring® C against the sealing face with increased force.

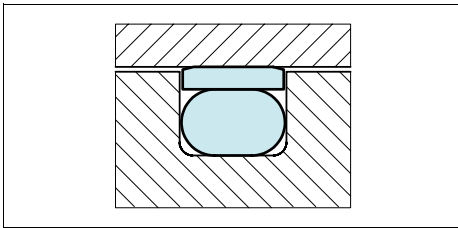

Figure 26 Turcon® Glyd Ring® C

The geometry of the Turcon® Glyd Ring® ensures a good static sealing and allows the lubricating hydrodynamic oil film to be built under the seal in reciprocating applications.

Notches

To assure that a rapid energizing of the seal takes place at sudden changes of pressure and direction, radial notches are machined on both sides of the seal.

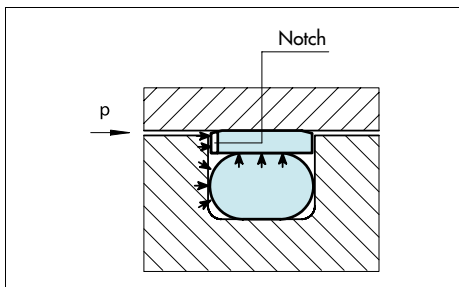

Figure 27 Turcon® Glyd Ring® C with notches on both sides

Advantages

- No stick-slip effect when starting for smooth operation
- Minimum static and dynamic friction coefficient for minimum energy loss and operating temperature
- Suitable for non-lubricating fluids depending on seal material for optimum design flexibility
- High wear resistance ensures long service life
- No adhesive effect to the mating surface during long period of inactivity or storage
- Suitable for most hydraulic fluids in relation with most modern hardware materials and surface finishes depending on material selected
- Suitable for new environmentally safe hydraulic fluids

Application Examples

Over several decades the Turcon® Glyd Ring® has been successfully implemented as a double-acting piston seal for hydraulic components. Applications include:

- Machine tools
- Robotics
- Handling machinery
- Manipulators
- Valves for hydraulic & pneumatic circuits
- Fittings
- Testing machinery
- Hydraulic power steering
- Brake systems
- Brake boosters
- Low temperature hydraulics
- Chemical processing equipment
- Filling machines



Technical Data

Operating conditions:

The Turcon® Glyd Ring® C is recommended for reciprocating movements (with a length of stroke at least twice the groove width).

Pressure:	5,800 psi (40 MPa) standard
Velocity:	Up to 50 ft/s (15 m/s)
Frequency:	Up to 5 Hz
Temperature:	-49°F to +392°F (-45°C to +200°C)
Media:	Mineral oil-based hydraulic fluids, barely flammable hydraulic fluids, environmentally safe hydraulic fluids (biological degradable oils), water, air and others, depending on the O-Ring material compatibility.
Clearance:	The maximum permissible radial clearance S _{max} , as shown in the table III, as a function of the operating pressure and functional diameter.

Important Note:

The above data are maximum values and cannot be used at the same time. e.g. the maximum operating speed depends on material type, pressure, temperature and gap value. Temperature range also dependent on medium.

Materials

Standard Application:

For hydraulic components in mineral oils containing or medium with good lubricating performance

Seal ring:	Turcon® T 46
Energizer:	O-Ring NBR 70 shore A or FKM 70 Shore A depending on the temperature
Set code:	T46N or T46V

Special Application:

Short stroke movements, non-lubricating fluids or pneumatic applications require self-lubricating sealing materials. Therefore we recommend:

Seal ring:	Turcon® T 40
Energizer:	O-Ring NBR 70 Shore A or FKM 70 Shore A depending on the temperature
Set code:	T40N or T40V

If low friction coefficient is required, we recommend:

Seal ring:	Turcon® T05
Energizer:	O-Ring NBR 70 Shore A or FKM 70 Shore A depending on the temperature. For special requirements other elastomers are available upon request
Set code:	T05N or T05V

If rougher surface finish must be sealed, we recommend:

Seal ring:	Zurcon® Z51
Energizer:	O-Ring NBR 70 Shore A
Set code:	Z51N

If exposure to water is required, we recommend:

Seal ring:	Zurcon® Z80
Energizer:	O-Ring NBR 70 Shore A
Set code:	Z80N

For pneumatics applications we recommend a specific pneumatic version, the Turcon® Glyd Ring® APG, which fits the same groove dimensions. This series has a reduced O-Ring squeeze adapted to this function.



Table XX Turcon® and Zurcon® Materials for Glyd Ring®

Material, Applications, Properties	Code	O-Ring Material	Code	O-Ring Operating Temp.* °F	Mating Surface Material	PSI Max.
Turcon® T46 Standard material for hydraulics, high compressive strength, good sliding and wear properties, good extrusion resistance, BAM tested. Bronze-filled Color: grayish to dark brown	T46	NBR - 70 Shore A	N	-22 to +212	Steel tubes Steel, hardened Cast iron	5,800***
		NBR - Low temp. 70 Shore A	T	-49 to +176		
		FKM - 70 Shore A	V	-14 to +392		
Turcon® T24 For all lubricating and non-lubricating hydraulic fluids, soft mating surfaces. Carbon-filled Color: black	T24	NBR - 70 Shore A	N	-22 to +212	Steel Steel, hardened Cast iron Stainless steel Aluminium Bronze	3,625***
		NBR - Low temp. 70 Shore A	T	-49 to +176		
		FMK - 70 Shore A	V	-14 to +392		
		EPDM - 70 Shore A	E**	-49 to +293		
Turcon® T05 For all lubricating hydraulic fluids, hard mating surfaces, very good sliding properties, low friction. Color: turquoise	T05	NBR - 70 Shore A	N	-22 to +212	Steel tubes Steel, hardened	2,900
		NBR - Low temp. 70 Shore A	T	-49 to +176		
		FKM - 70 Shore A	V	-14 to +392		
Turcon® T40 For all lubricating and non-lubricating hydraulic fluids, water hydraulic, soft mating surfaces. Surface texture not suitable for gases. Carbon-filled Color: gray	T40	NBR - 70 Shore A	N	-22 to +212	Steel Cast iron Stainless steel Aluminium Bronze Alloys	3,625***
		NBR - Low temp. 70 Shore A	T	-49 to +176		
		FMK - 70 Shore A	V	-14 to +392		
		EPDM - 70 Shore A	E**	-49 to +293		
Zurcon® Z51 For lubricating hydraulic fluids, high abrasion resistance, high extrusion resistance, limited chemical resistance. Cast polyurethane Color: yellow to light brown	Z51	NBR - 70 Shore A	N	-22 to +212	Steel Steel, hardened Cast iron Ceramic coating Stainless steel	5,800***
		NBR - Low temp. 70 Shore A	T	-49 to +176		
Zurcon® Z80 For all lubricating and non-lubricating hydraulic fluids, high abrasion resistance, very good chemical resistance, limited temperature resistance. Ultra high molecular weight polyethylene Color: white to off-white	Z80	NBR - 70 Shore A	N	-22 to +176	Steel Cast iron Stainless steel Aluminium Bronze Alloys	5,800***
		NBR - Low temp. 70 Shore A	T	-49 to +203		

* The O-Ring operation temperature is only valid in mineral hydraulic oil. ** Material not suitable for mineral oils.

*** max. Ø 2300 mm (90 inches) BAM: Tested by "Bundes Anstalt Materialprüfung, Germany".

□ Highlighted materials are standard.



■ Installation Recommendation (Inch Piston Series)

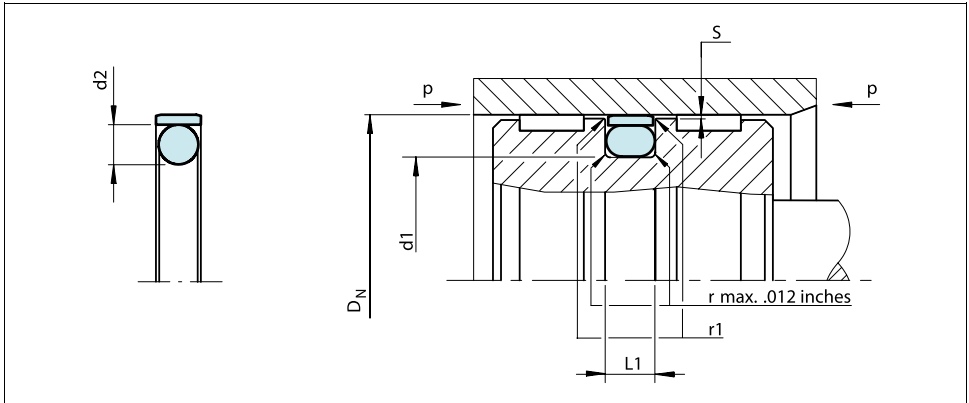

Figure 29 Installation drawing

Table XXI Installation recommendation

Dash No.	Bore Diameter		Groove Diameter	Groove Width	Radius	Radial Clearance			O-Ring Cross-Section
	D_N H9					S max.*			
	Standard Application	Light Application	d_1 h9	$L_1 + .008$	r_1	10 Mpa 1500 psi	20 Mpa 3000 psi	40 Mpa 5800 psi	d_2
006-010	.25 - .562	.625 - 2.875	$D_N - .143$.079	.020	.002	.002	.002	.070
011-039	.25 - .562	.625 - 2.875	$D_N - .172$.079	.020	.003	.003	.003	.070
111-151	.625 - .687	.750 - 3.000	$D_N - .236$.112	.020	.003	.003	.003	.103
206-222	.750 - 1.750	1.875 - 6.750	$D_N - .300$.149	.030	.003	.003	.003	.139
223-260	.750 - 1.750	1.875 - 6.750	$D_N - .363$.149	.030	.003	.003	.003	.139
325-350	1.875 - 5.000	-	$D_N - .491$.221	.050	.004	.004	.004	.210
426-437	5.125 - 25.500	-	$D_N - .593$.297	.060	.004	.004	.004	.275
438-445	5.125 - 25.500	-	$D_N - .718$.297	.060	.004	.004	.004	.275
446-474	5.125 - 25.500	-	$D_N - .968$.297	.060	.004	.004	.004	.275

* At pressures > 40 MPa (5,800 psi) use diameter tolerance H8/f8 (bore/piston) in area of the seal.



Ordering Example

Turcon® Glyd Ring®, complete with O-Ring, standard application, Series C

Dash No.: 215
TSS Part No.: PG470B215-T46N

Select the material from Table XX. The corresponding code numbers are appended to the TSS Part No. Together they form the TSS Article No.

All intermediate sizes not shown in Table XXII will have special TSS Part Numbers.

TSS Article No.	PG 47	0	B	215	-	T46	N
TSS Series No.							
Notched (Standard) (substitute "W" to omit notch)							
Groove Standard							
Dash Size							
Quality Index							
Material code (Seal ring)							
Material code (O-Ring)							

Table XXII Installation dimensions/TSS Part No.

Bore Diameter	Groove Diameter	Groove Width	TSS Part No.
D _N H9	d ₁ h9	L ₁ +.010	
.250	.143	.079	PG470B006
.313	.143	.079	PG470B008
.375	.143	.079	PG470B010
.438	.173	.079	PG470B011
.500	.173	.079	PG470B012
.563	.173	.079	PG470B013
.625	.173	.079	PG470B014
.688	.515	.079	PG470B015
.750	.577	.079	PG470B016
.813	.640	.079	PG470B017
.875	.702	.079	PG470B018
.938	.765	.079	PG470B019
1.000	.763	.112	PG470B117
1.063	.826	.112	PG470B118
1.125	.888	.112	PG470B119
1.188	.951	.112	PG470B120
1.250	1.013	.112	PG470B121
1.313	1.076	.112	PG470B122
1.375	1.138	.112	PG470B123
1.438	1.201	.112	PG470B124
1.500	1.263	.112	PG470B125
1.563	1.326	.112	PG470B126
1.625	1.388	.112	PG470B127
1.688	1.451	.112	PG470B128

Bore Diameter	Groove Diameter	Groove Width	TSS Part No.
D _N H9	d ₁ h9	L ₁ +.010	
1.750	1.513	.112	PG470B129
1.813	1.576	.112	PG470B130
1.875	1.638	.112	PG470B131
1.938	1.701	.112	PG470B132
2.000	1.763	.112	PG470B133
2.063	1.826	.112	PG470B134
2.125	1.888	.112	PG470B135
2.188	1.951	.112	PG470B136
2.250	2.013	.112	PG470B137
2.313	2.076	.112	PG470B138
2.375	2.138	.112	PG470B139
2.438	2.201	.112	PG470B140
2.500	2.263	.112	PG470B141
2.625	2.262	.149	PG470B229
2.750	2.387	.149	PG470B230
2.875	2.512	.149	PG470B231
3.000	2.637	.149	PG470B232
3.125	2.762	.149	PG470B233
3.250	2.887	.149	PG470B234
3.375	3.012	.149	PG470B235
3.500	3.137	.149	PG470B236
3.625	3.262	.149	PG470B237
3.750	3.387	.149	PG470B238
3.875	3.512	.149	PG470B239



Bore Diameter	Groove Diameter	Groove Width	TSS Part No.
D_N H9	d_1 h9	L_1 +.010	
4.000	3.509	.221	PG470B342
4.125	3.634	.221	PG470B343
4.250	3.759	.221	PG470B344
4.375	3.884	.221	PG470B345
4.500	4.009	.221	PG470B346
4.625	4.134	.221	PG470B347
4.750	4.259	.221	PG470B348
4.875	4.384	.221	PG470B349
5.000	4.509	.221	PG470B350
5.125	4.532	.297	PG470B426
5.250	4.657	.297	PG470B427
5.375	4.782	.297	PG470B428
5.500	4.907	.297	PG470B429
5.625	5.032	.297	PG470B430
5.750	5.157	.297	PG470B431
5.875	5.282	.297	PG470B432
6.000	5.407	.297	PG470B433
6.125	5.532	.297	PG470B434
6.250	5.657	.297	PG470B435
6.375	5.782	.297	PG470B436
6.500	5.907	.297	PG470B437
6.750	6.032	.297	PG470B438
7.000	6.282	.297	PG470B439
7.250	6.532	.297	PG470B440
7.500	6.782	.297	PG470B441
7.750	7.032	.297	PG470B442
8.000	7.282	.297	PG470B443
8.250	7.532	.297	PG470B444
8.500	7.782	.297	PG470B445
9.000	8.032	.297	PG470B446
9.500	8.532	.297	PG470B447
10.000	9.032	.297	PG470B448
10.500	9.532	.297	PG470B449

The sizes listed in **bold** font are preferred sizes (more likely to be available for immediate shipment). Other dimensions and all intermediate sizes up to 106 inches (2700mm) diameter can be supplied.



Zurcon[®] Glyd Ring[®] P

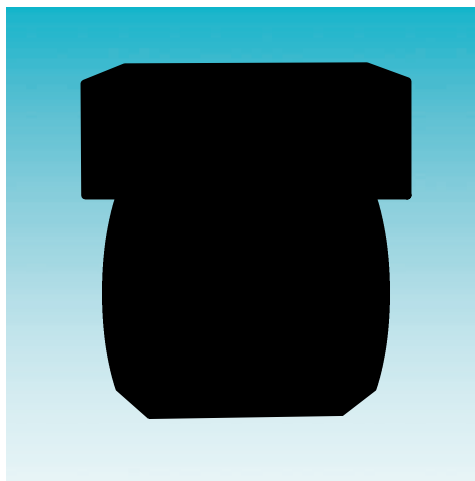

- Double-Acting -
- Elastomer-Energized Zurcon[®] Slipper Seal -

- Materials -
- Zurcon[®] -





■ Zurcon® Glyd Ring® P

Description

The double-acting Zurcon® Glyd Ring® P is a combination of a Zurcon®-based slipper seal with a step cut and an energizing rectangular elastomeric ring. It is produced with an interference fit at closed step cut which together with the squeeze of the rectangular energizer ring ensures a good sealing effect even at low pressure.

At higher system pressures, the rectangular ring is energized by the fluid, pushing the Zurcon® Glyd Ring® P against the sealing face with increased force. At high peak pressures, the Zurcon® step cut seal ring can follow ballooning of the tube without losing the sealability.

Due to the Zurcon® high strength plastic material, two times bigger extrusion gaps are possible compared with Turcon® materials. The step cut in the ring is necessary for installation in closed grooves and for the flexibility of the seal ring due to the high stiffness of the material.

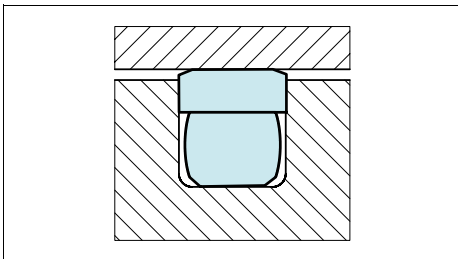

Figure 30 Zurcon® Glyd Ring® P

Step Cut

For easy installation on the piston and for the flexibility of the seal ring a precision step cut is produced by special tool technology.

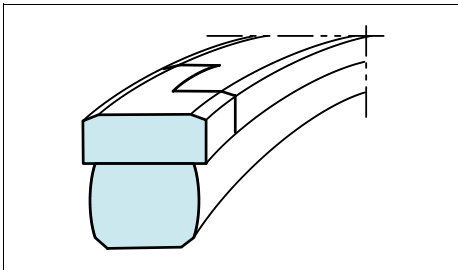

Figure 31 Step cut on Zurcon® Glyd Ring® P

Advantages

- Easy installation on piston without special tools
- Due to large extrusion gap, safe use even with soiled media
- Simple groove design, one piece piston possible
- Increased clearance compared to Turcon® Glyd Ring® seals (approx. +50%), depending on operation conditions
- Resistant against shock loads
- High wear resistant material ensures long service life

Application Examples

- Telescopic cylinders
- Construction machinery, e.g. excavators
- Truck cranes
- Fork lifts

It is particularly recommended for heavy duty applications

Technical Data

Operating conditions:

The Zurcon® Glyd Ring® P is recommended for reciprocating (with a length of stroke at least twice the groove width) movements where the dimensional gap between piston and tube is as big as possible or where high pressure peaks occur during operation.

Pressure: 7,250 psi (50 MPa) standard
14,500 psi (100 MPa) pressure peak

Velocity: Up to 3.3 ft/s (1 m/s)

Temperature: -22°F to +230°F (-30°C to +110°C)
-40°F to +212°F (-40°C to +100°C)
-5°F to +284°F (-15°C to +140°C)

Media: Mineral oil-based hydraulic fluids

Important Note:

The above data are maximum values and cannot be used at the same time. e.g. the maximum operating speed depends on material type, pressure, temperature and gap value. Temperature range also dependent on medium.



Materials

Standard Application:

- For hydraulic components in mineral oils or media with good lubricating performance

Seal ring: Zurcon[®] Z66

Energizer: Rectangular ring in NBR 70 shore A, code N

Set reference: Z66N

Low Temperature Application:

Seal ring: Zurcon[®] Z66

Energizer: Rectangular ring in low temp. NBR 70 shore A, code T

Set reference: Z66T

High Temperature Application:

Seal ring: Zurcon[®] Z66

Energizer: Rectangular ring in FKM 70 shore A, code V

Set reference: Z66V



■ Installation Recommendation (Inch Piston Series)

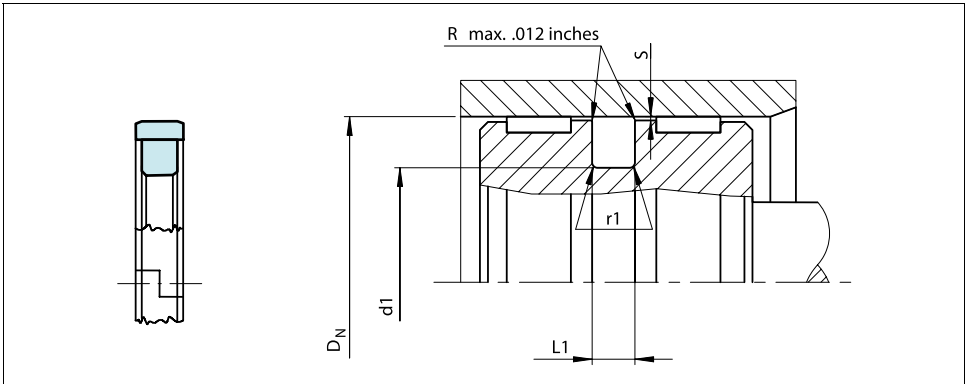

Figure 33 Installation drawing

Table XXIII Installation dimensions/TSS Part No.

TSS Series No.	Bore Diameter D_N H9	Groove Diameter	Groove Width	Radius	Radial Clearance
	Standard Application	d_1 H9	$L_1 + .008$	r_1	S max.* 40 MPa 5800 psi
PGPA	2.000 - 3.249	$D_N - .538$.282	.025	.032
PGPB	3.250 - 5.499	$D_N - .558$.282	.035	.040
PGPC	2.500 - 3.249	$D_N - .538$.312	.025	.032
PGPD	3.250 - 4.500	$D_N - .558$.312	.035	.040
PGPE	5.500 - 8.999	$D_N - .760$.377	.035	.050

Ordering Example

Zurcon® Glyd Ring® P for ISO groove
 TSS Series No.: PGPC
 TSS Part No.: PGPC03000
 TSS seal ring material code: Z66
 Energizer material code: N
 Set code: Z66N

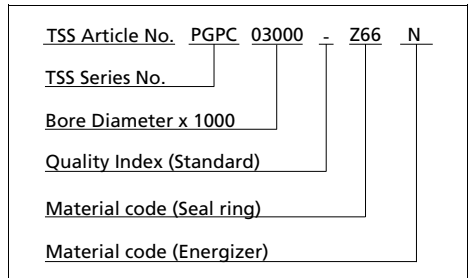



Table XXIV Installation Dimensions / TSS Part No.

Bore Diameter	Groove Diameter	Groove Width	TSS Part No.
D_N H9	d_1 h9	$L_1 + .010$	
2.000	1.462	.282	PGPA02000
2.250	1.712	.282	PGPA02250
2.500	1.962	.282	PGPA02500
2.500	1.962	.312	PGPC02500
2.750	2.212	.282	PGPA02750
2.750	2.212	.312	PGPC02750
3.000	2.462	.282	PGPA03000
3.000	2.462	.312	PGPC03000
3.250	2.692	.282	PGPB03250
3.250	2.692	.312	PGPD03250
3.500	2.942	.282	PGPB03500
3.500	2.942	.312	PGPD03500
3.750	3.192	.282	PGPB03750
3.750	3.192	.312	PGPD03750
4.000	3.442	.282	PGPB04000
4.000	3.442	.312	PGPD04000
4.250	3.692	.282	PGPB04250
4.250	3.692	.312	PGPD04250
4.500	3.942	.282	PGPB04500
4.500	3.942	.312	PGPD04500
4.750	4.192	.282	PGPB04750
5.000	4.442	.282	PGPB05000
5.250	4.692	.282	PGPB05250
5.500	4.740	.377	PGPE05500
5.750	4.990	.377	PGPE05750
6.000	5.240	.377	PGPE06000
6.500	5.740	.377	PGPE06500
7.000	6.240	.377	PGPE07000
7.500	6.740	.377	PGPE07500
8.000	7.240	.377	PGPE08000

The sizes listed in **bold** font are preferred sizes (more likely to be available for immediate shipment). Other dimensions and all intermediate sizes up to 10 inches (254mm) diameter can be supplied.

TURCON[®] STEPSEAL[®] 2K



- Single-Acting -
- O-Ring-Energized Turcon[®] Slipper Seal -

- Material -
Turcon[®] or Zurcon[®]





■ Turcon® Stepseal® 2K*

Description

The Stepseal® 2K is a single-acting seal element consisting of a seal ring of high-grade Turcon® or Zurcon® materials and an O-Ring as an energizing element.

The Stepseal® 2K was originally developed and patented by Trelleborg Sealing Solutions as a rod seal. Due to its outstanding properties, however, it is equally well suited as a single-acting piston seal where high demands are made on positional accuracy and free movement.

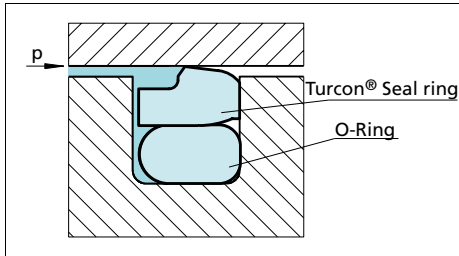

Figure 34 Turcon® Stepseal® 2K

Advantages

- High static and dynamic sealing effect
- Stick-slip-free operation for precise control
- High abrasion resistance and high resistance to extrusion
- Long service life
- Simple groove design, one-piece piston possible
- Wide range of application temperatures and high resistance to chemicals, depending on the choice of O-Ring material
- Simple installation without seal edge deformation
- Available for all diameters up to 106 inches (2,700 mm)
- Low friction

* Patented and patent pending geometry

Application Examples

The Turcon® Stepseal® 2K is the recommended sealing element for single-acting pistons in hydraulic components for:

- Injection molding machines
- Machine tools
- Presses

It is particularly recommended in floating piston accumulators as the primary seal on the oil side in combination with AQ-Seal® and AQ-Seal® 5.

Technical Data

Operating conditions

Pressure: Up to 11,600 psi (80 MPa)

Velocity: Up to 50 ft/s (15 m/s),
frequency up to 5 Hz

Temperature: -49°F to +392°F (-45°C to +200°C)**

Media: Mineral oil-based hydraulic fluids, flame retardant hydraulic fluids, environmentally safe hydraulic fluids (bio-oils), water, air and others, depending on the O-Ring material (see Table XXV)

Clearance: The maximum permissible radial clearance S_{max} is shown in Table XXVI, as a function of the operating pressure and functional diameter.

Important Note:

The above data are maximum values and cannot be used at the same time. e.g. the maximum operating speed depends on material type, pressure, temperature and gap value. Temperature range also dependent on medium.

***) in the case of unpressurized applications in temperatures below 32 °F (0 °C) please contact our application engineers for assistance!



Materials

Standard Application:

- For hydraulic components in mineral oils containing zinc or medium with good lubricating performance

Seal ring: Turcon® T46

Energizer: O-Ring NBR 70 Shore A or FKM 70 Shore A depending on the temperature

Set reference: T46N or T46V

Special Application:

- Non-lubricating fluids or pneumatic applications require self-lubricating sealing materials. Therefore we recommend:

Seal ring: Turcon® T29

Energizer: O-Ring NBR 70 Shore A or FKM 70 Shore A depending on the temperature

Set reference: T29N or T29V

- Rough mating surface finish and improved leakage control

Seal ring: Zurcon® Z51

Energizer: O-Ring NBR 70 Shore A

Set reference: Z51N



Table XXV Turcon® and Zurcon® materials for Stepseal® 2K

Material, Applications, Properties	Code	O-Ring Material	Code	O-Ring Operating Temp.* °F	Mating Surface Material	PSI Max.
Turcon® T46 Standard material for hydraulics, high compressive strength, good sliding and wear properties, good extrusion resistance, BAM tested. Bronze-filled Color: grayish to dark brown	T46	NBR-70 Shore A	N	-22 to +212	Steel tube Steel, hardened Cast iron	10,150
		NBR-Low temp. 70 Shore A	T	-49 to +176		
		FKM-70 Shore A	V	-14 to +392		
Turcon® T08 Very high compressive strength, very good extrusion resistance. High bronze-filled Color: light to dark brown	T08	NBR-70 Shore A	N	-22 to +212	Steel tube Steel, hardened Cast iron	11,600
		NBR-Low temp. 70 Shore A	T	-49 to +176		
		FKM-70 Shore A	V	-14 to +392		
Turcon® T40 For all lubricating and non-lubricating hydraulic fluids, water hydraulic, soft mating surfaces. Surface texture not suitable for gases. Carbon fiber-filled Color: gray	T40	NBR-70 Shore A	N	-22 to +212	Steel Cast iron Stainless steel Aluminium Bronze Alloys	4,350
		NBR-Low temp. 70 Shore A	T	-49 to +176		
		FKM-70 Shore A	V	-14 to +392		
		EPDM-70 Shore A	E**	-49 to +293		
Turcon® T29 For all lubricating and non-lubricating hydraulic fluids, hydraulic oils without zinc, soft mating surfaces, good extrusion resistance. Surface texture not suitable for gases. High carbon fiber-filled Color: gray	T29	NBR-70 Shore A	N	-22 to +212	Steel Cast iron Stainless steel Aluminium Bronze	10,150
		NBR-Low temp. 70 Shore A	T	-49 to +176		
		FKM-70 Shore A	V	-14 to +392		
		EPDM-70 Shore A	E**	-49 to +293		
Turcon® T05 For all lubricating hydraulic fluids, hard mating surfaces, very good slide properties, low friction. Color: turquoise	T05	NBR-70 Shore A	N	-22 to +212	Steel tube Steel, hardened	3,625
		NBR-Low temp. 70 Shore A	T	-49 to +176		
		FKM-70 Shore A	V	-14 to +392		
Turcon® T42 For all lubricating and non-lubricating hydraulic fluids, good chemical resistance, good dielectric properties. Glass fiber-filled + MoS ₂ Color: gray to blue	T42	NBR-70 Shore A	N	-22 to +212	Steel tube Steel, hardened Cast iron	5,800
		NBR-Low temp. 70 Shore A	T	-49 to +176		
		FKM-70 Shore A	V	-14 to +392		
Turcon® T10 For oil hydraulic and pneumatic, for all lubricating and non-lubricating fluids, high extrusion resistance, good chemical resistance, BAM tested. Carbon, graphite-filled Color: black	T10	NBR-70 Shore A	N	-22 to +212	Steel Stainless steel	10,150
		NBR-Low temp. 70 Shore A	T	-49 to +176		
		FKM-70 Shore A	V	-14 to +392		
		EPDM-70 Shore A	E**	-49 to +293		
Zurcon® Z51*** For lubricating hydraulic fluids, high abrasion resistance, high extrusion resistance, limited chemical resistance. Cast polyurethane Color: yellow to light-brown	Z51	NBR-70 Shore A	N	-22 to +212	Steel Steel, hardened Cast iron Ceramic coating Stainless steel	11,600
		NBR-Low temp. 70 Shore A	T	-49 to +176		
Zurcon® Z80 For lubricating and non-lubricating hydraulic fluids, high abrasion resistance, very good chemical resistance, limited temp. resistance. Ultra high molecular weight polyethylene Color: white to off-white	Z80	NBR-70 Shore A	N	-22 to +176	Steel Stainless steel Aluminium Bronze Ceramic coating	6,525
		NBR-Low temp. 70 Shore A	T	-49 to +176		

* The O-Ring Operation temperature is only valid in mineral hydraulic oil. ** Material not suitable for mineral oils

*** max. Ø 2300 mm 90.000 inches BAM: Tested by "Bundes Anstalt Materialprüfung, Germany".

□ Highlighted materials are standard.



■ Installation Recommendation (Inch Piston Series)

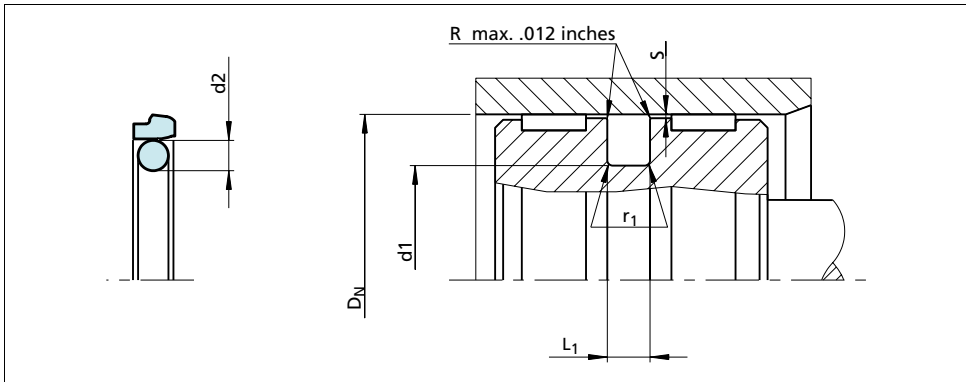

Figure 35 Installation drawing

Table XXVI Installation recommendation - Standard recommendation

TSS Series No.	Bore Diameter			Groove Diameter	Groove Width	Radius	Radial Clearance			O-Ring Cross-Section
	DN H9						S max*			
	Standard Application	Light Application	Heavy-Duty Application	d ₁ h9	L ₁ +0.2	r ₁	10 MPa 1500 psi	20 MPa 3000 psi	40 MPa 5800 psi	d ₂
PSF0	.313 - .749	.750 - 1.000	-	DN - .193	.087	.020	.012	.009	.007	.070
PSF1	.750 - 1.499	1.500 - 2.500	-	DN - .287	.126	.020	.016	.012	.008	.103
PSF2	1.500 - 2.499	2.500 - 8.000	.625 - 1.499	DN - .421	.165	.025	.016	.012	.009	.139
PSF3	2.500 - 7.999	8.000 - 10.000	1.00 - 2.499	DN - .594	.248	.030	.020	.014	.010	.210
PSF4	8.000 - 9.999	10.000 - 26.000	3.125 - 7.999	DN - .807	.319	.035	.024	.017	.012	.275
PSF5	10.000 - 26.000	-	5.250 - 9.999	DN - .945	.319	.035	.024	.017	.012	.275

Ordering example

Turcon® Stepseal® 2K, complete with O-Ring, standard application, Series PSF4 (from Table XXVI).

Piston diameter: DN = 8.000 inches

TSS Part No. PSF408000 (from Table XXVII)

Select the material from Table XXV. The corresponding code numbers are appended to the TSS Part No. (from Table XXVII). Together they form the TSS Article No.

For all intermediate sizes not shown in Table XXVII, the TSS Article No. can be determined from the example opposite.

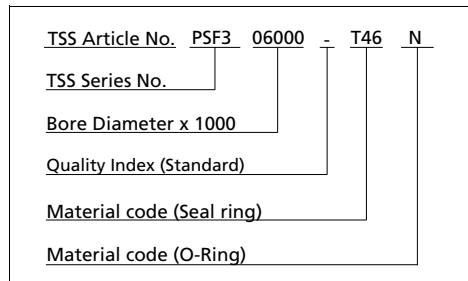



Table XXVII Installation dimensions / TSS Part No.

Bore Diameter	Groove Diameter	Groove Width	TSS Part No.
D _N H9	d ₁ h9	L ₁ +.008	
.500	.307	.087	PSF000500
.563	.370	.087	PSF000563
.625	.432	.087	PSF000625
.688	.495	.087	PSF000688
.750	.557	.087	PSF000750
.750	.329	.165	PSF200750
.813	.526	.126	PSF100813
.813	.392	.165	PSF200813
.875	.588	.126	PSF100875
.875	.454	.165	PSF200875
.938	.651	.126	PSF100938
.938	.517	.165	PSF200938
1.000	.713	.126	PSF101000
1.000	.579	.165	PSF201000
1.063	.776	.126	PSF101063
1.063	.642	.165	PSF201063
1.125	.838	.126	PSF101125
1.125	.704	.165	PSF201125
1.188	.901	.126	PSF101188
1.188	.767	.165	PSF201188
1.250	.963	.126	PSF101250
1.250	.829	.165	PSF201250
1.313	1.026	.126	PSF101313
1.313	.892	.165	PSF201313
1.375	1.088	.126	PSF101375
1.375	.954	.165	PSF201375
1.438	1.151	.126	PSF101438
1.438	1.017	.165	PSF201438
1.500	1.213	.126	PSF101500
1.500	1.079	.165	PSF201500
1.500	0.906	.248	PSF301500
1.563	1.142	.165	PSF201563
1.563	.969	.248	PSF301563
1.625	1.204	.165	PSF201625
1.625	1.031	.248	PSF301625
1.688	1.267	.165	PSF201688

Bore Diameter	Groove Diameter	Groove Width	TSS Part No.
D _N H9	d ₁ h9	L ₁ +.008	
1.688	1.094	.248	PSF301688
1.750	1.329	.165	PSF201750
1.750	1.156	.248	PSF301750
1.813	1.392	.165	PSF201813
1.813	1.219	.248	PSF301813
1.875	1.454	.165	PSF201875
1.875	1.281	.248	PSF301875
1.938	1.517	.165	PSF201938
1.938	1.344	.248	PSF301938
2.000	1.579	.165	PSF202000
2.000	1.406	.248	PSF302000
2.125	1.704	.165	PSF202125
2.125	1.531	.248	PSF302125
2.250	1.829	.165	PSF202250
2.250	1.656	.248	PSF302250
2.375	1.954	.165	PSF202375
2.375	1.781	.248	PSF302375
2.500	2.079	.165	PSF202500
2.500	1.906	.248	PSF302500
2.625	2.204	.165	PSF202625
2.625	2.031	.248	PSF302625
2.750	2.329	.165	PSF202750
2.750	2.156	.248	PSF302750
2.875	2.454	.165	PSF202875
2.875	2.281	.248	PSF302875
3.000	2.579	.165	PSF203000
3.000	2.406	.248	PSF303000
3.125	2.704	.165	PSF203125
3.125	2.531	.248	PSF303125
3.250	2.829	.165	PSF203250
3.250	2.656	.248	PSF303250
3.375	2.954	.165	PSF203375
3.375	2.781	.248	PSF303375
3.500	3.079	.165	PSF203500
3.500	2.906	.248	PSF303500
3.625	3.204	.165	PSF203625



Turcon® Stepseal® 2K

Bore Diameter	Groove Diameter	Groove Width	TSS Part No.
D _N H9	d ₁ h9	L ₁ +.008	
3.625	3.031	.248	PSF303625
3.750	3.329	.165	PSF203750
3.750	3.156	.248	PSF303750
3.875	3.454	.165	PSF203875
3.875	3.281	.248	PSF303875
4.000	3.579	.165	PSF204000
4.000	3.406	.248	PSF304000
4.125	3.704	.165	PSF204125
4.125	3.531	.248	PSF304125
4.250	3.829	.165	PSF204250
4.250	3.656	.248	PSF304250
4.375	3.954	.165	PSF204375
4.375	3.781	.248	PSF304375
4.500	4.079	.165	PSF204500
4.500	3.906	.248	PSF304500
4.625	4.031	.248	PSF304625
4.625	3.818	.319	PSF404625
4.750	4.156	.248	PSF304750
4.750	3.943	.319	PSF404750
4.875	4.281	.248	PSF304875
4.875	4.068	.319	PSF404875
5.000	4.406	.248	PSF305000
5.000	4.193	.319	PSF405000
5.125	4.531	.248	PSF305125
5.125	4.318	.319	PSF405125
5.250	4.656	.248	PSF305250
5.250	4.443	.319	PSF405250
5.375	4.781	.248	PSF305375
5.375	4.568	.319	PSF405375
5.500	4.906	.248	PSF305500
5.500	4.693	.319	PSF405500
5.625	5.031	.248	PSF305625
5.625	4.818	.319	PSF405625
5.750	5.156	.248	PSF305750
5.750	4.943	.319	PSF405750
6.000	5.406	.248	PSF306000

Bore Diameter	Groove Diameter	Groove Width	TSS Part No.
D _N H9	d ₁ h9	L ₁ +.008	
6.000	5.193	.319	PSF406000
6.250	5.656	.248	PSF306250
6.250	5.443	.319	PSF406250
6.500	5.906	.248	PSF306500
6.500	5.693	.319	PSF406500
6.750	6.156	.248	PSF306750
6.750	5.943	.319	PSF406750
7.000	6.406	.248	PSF307000
7.000	6.193	.319	PSF407000
7.250	6.656	.248	PSF307250
7.250	6.443	.319	PSF407250
7.500	6.906	.248	PSF307500
7.500	6.693	.319	PSF407500
7.750	7.156	.248	PSF307750
7.750	6.943	.319	PSF407750
8.000	7.193	.319	PSF408000
8.250	7.443	.319	PSF408250
8.500	7.693	.319	PSF408500
8.750	7.943	.319	PSF408750
9.000	8.193	.319	PSF409000
9.250	8.443	.319	PSF409250
9.500	8.693	.319	PSF409500
9.750	8.943	.319	PSF409750
10.000	9.193	.319	PSF410000
10.000	9.055	.319	PSF510000
10.500	9.693	.319	PSF410500
10.500	9.555	.319	PSF510500
11.000	10.193	.319	PSF411000
11.000	10.055	.319	PSF511000
11.500	10.693	.319	PSF411500
11.500	10.555	.319	PSF511500
12.000	11.055	.319	PSF512000
12.500	11.555	.319	PSF512500
13.000	12.055	.319	PSF513000
13.500	12.555	.319	PSF513500
14.000	13.055	.319	PSF514000





Bore Diameter	Groove Diameter	Groove Width	TSS Part No.
D_N H9	d_1 h9	$L_1 +.008$	
14.500	13.555	.319	PSF514500
15.000	14.055	.319	PSF515000
15.500	14.555	.319	PSF515500
16.000	15.055	.319	PSF516000
16.500	15.555	.319	PSF516500
17.000	16.055	.319	PSF517000
17.500	16.555	.319	PSF517500
18.000	17.055	.319	PSF518000
18.500	17.555	.319	PSF518500
19.000	18.055	.319	PSF519000
19.500	18.555	.319	PSF519500
20.000	19.055	.319	PSF520000

The sizes listed in **bold** font are preferred sizes (more likely to be available for immediate shipment). Other dimensions and all intermediate sizes up to 106 inches (2700mm) diameter can be supplied.



Turcon® Stepseal® 2K

TURCON[®] DOUBLE DELTA[®]

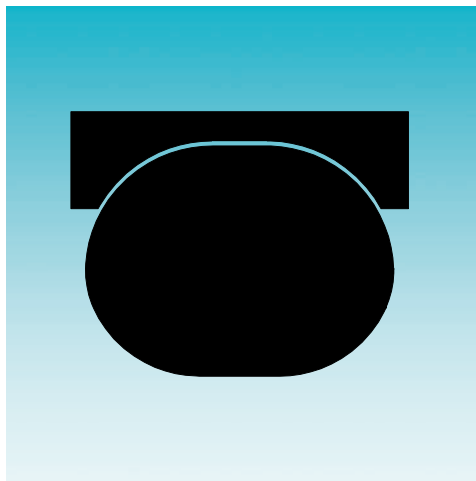

- Double-Acting -
- O-Ring-Energized Turcon[®] Slipper Seal -

- Material -
- Turcon[®] -





■ Turcon® Double Delta®

Description

The Turcon® Double Delta® is a rubber-energized plastic faced seal. The seal is designed to expand and improve the service parameters of O-Rings and is installed in existing O-Ring grooves.

The Double Delta® combines the flexibility and response of O-Rings with the wear and friction characteristics of the Turcon® materials in dynamic applications.

The figure below shows the cross section of the Double Delta®.

The double-acting performance of the seal comes from the symmetrical cross section which allows the seal to respond to pressure in both directions.

Initial contact pressure is provided by radial compression of the O-Ring. When the system pressure is increased the O-Ring transforms this into additional contact pressure, the contact pressure of the seal is thereby automatically adjusted so sealing is ensured under all service conditions.

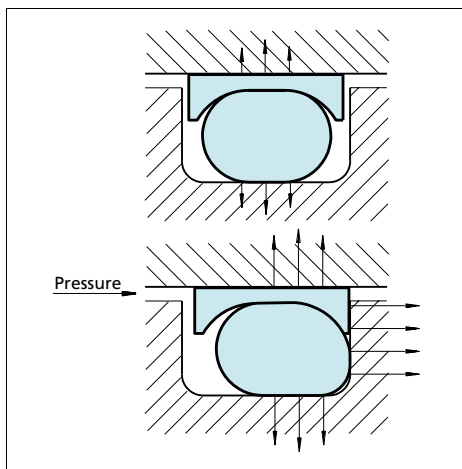

Figure 36 Turcon® Double Delta® without and with pressure

Advantages

- Compact groove dimensions and simple installation
- Low friction without stick-slip
- Resistance against wear and extrusion
- Piston seals available for all diameters from .25 to 40 inches (5 to 999.9 mm)
- Standard cross sections cover AS 568A and important metric O-Rings, other cross sections available on request.

Application Examples

The Turcon® Double Delta® is the recommended sealing element for double-acting pistons of hydraulic or pneumatic cylinders in sectors such as:

- Machine tools
- Handling devices
- Manipulators
- Valves
- Chemical process equipment

It is particularly recommended for light duty and small diameter applications.

Technical Data

Operating conditions

Pressure:	Up to 5,000 psi (35 MPa)
Velocity:	Up to 50 ft/s (15 m/s)
Temperature:	-49°F to +392°F (-45°C to +200°C) (according to O-Ring material)
Media:	Mineral oil, Non-flammable fluids, Environmentally safe fluids and others according to O-Ring material

Important Note:

The above data are maximum values and cannot be used at the same time. e.g. the maximum operating speed depends on material type, pressure, temperature and gap value. Temperature range also dependent on medium.



■ Materials

Standard Application:

- For hydraulic components with reciprocating movement in mineral oils containing zinc or medium with good lubricating performance and hard mating surface

Seal ring: Turcon® T46

Energizer: O-Ring NBR 70 Shore A or FKM 70 Shore A depending on the temperature

Special Application:

- Short stroke movements, poor lubricating fluids and soft mating surfaces

Seal ring: Turcon® T24

Energizer: O-Ring NBR 70 shore A or FKM 70 shore A (depending on the temp.)

- For low friction requirement in dynamic hydraulic components with good lubricating medium:

Seal ring: Turcon® T05

Energizer: O-Ring NBR 70 shore A or FKM 70 shore A (depending on the temp.)

- For specific applications other material combinations as listed may also be used. Please contact your local Trelleborg Sealing Solutions sales office.

Material for the seal set:

Example:	T05 plus FKM - O-Ring	T05V
	T46 plus NBR - O-Ring	T46N

■ Design Instructions

Lead-in Chamfers

In order to avoid damage to the seal during installation, lead-in chamfers and rounded edges must be provided on the bore or piston rod (Figure 27).

The minimum length of the lead-in chamfer depends on the profile size of the seal and can be seen from the following tables.

Table XXVIII Lead-in Chamfers

Lead-in Chamfer* Diameter increase ΔD_N min.	O-Ring Cross Section** d_2
.055	.070 - .078
.071	.094 - .103
.094	.118 - .157
.126	.196 - .224
.157	.275 - .331

* Though not less than 1.5% of service diameter (bore/piston diameter).

** The O-Ring cross section d_2 can be found in the appropriate tables "Installation Dimensions", XXX, XXX and XXXI.

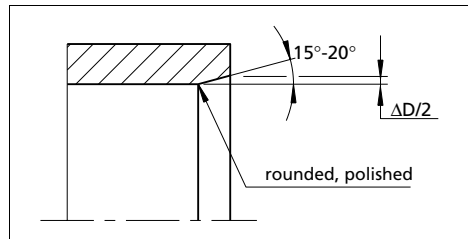

Figure 37 Lead-in chamfers



■ **Materials**

Table XXIX Turcon® Materials for Double Delta®

Material, Applications, Properties	Code	O-Ring Material	Code	O-Ring Operating Temp.* °F	Mating Surface Material	PSI Max.
Turcon® T46 Standard material for hydraulics, high compressive strength, good sliding and wear properties, good extrusion resistance, BAM tested. Bronze-filled Color: grayish to dark brown	T46	NBR - 70 Shore A	N	-22 to +212	Steel tubes Steel, hardened Cast iron	5,000
		NBR - Low temp. 70 Shore A	T	-49 to +176		
		FKM - 70 Shore A	V	-14 to +392		
Turcon® T24 For all lubricating and non-lubricating hydraulic fluids, soft mating surfaces. Carbon-filled Color: black	T24	NBR - 70 Shore A	N	-22 to +212	Steel, hardened Cast iron Stainless steel Aluminium Bronze	3,625
		NBR - Low temp. 70 Shore A	T	-49 to +176		
		FMK - 70 Shore A	V	-14 to +392		
		EPDM - 70 Shore A	E**	-49 to +293		
Turcon® T05 For all lubricating hydraulic fluids, hard mating surfaces, very good sliding properties, low friction. Color: turquoise	T05	NBR - 70 Shore A	N	-22 to +212	Steel tubes Steel, hardened	2,900
		NBR - Low temp. 70 Shore A	T	-49 to +176		
		FKM - 70 Shore A	V	-14 to +392		

* The O-Ring operation temperature is only valid in mineral hydraulic oil. ** Material not suitable for mineral oils.
 BAM: Tested by "Bundes Anstalt Materialprüfung, Germany". Highlighted materials are standard.



■ Installation Recommendation (Inch Piston Series)

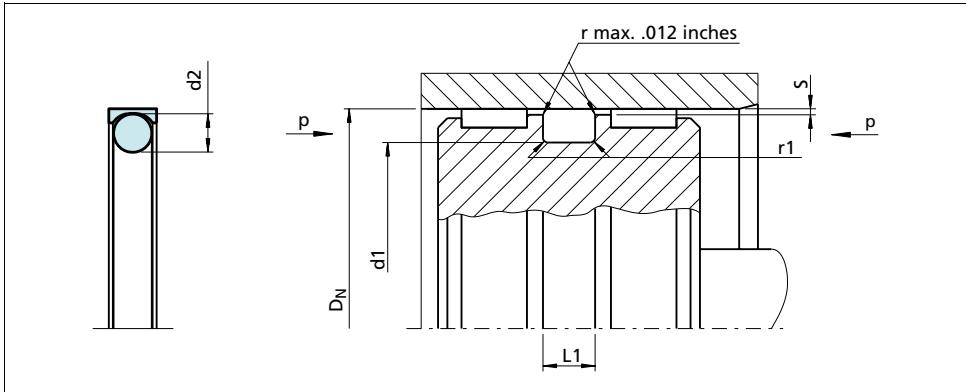

Figure 38 Installation drawing

Table XXX Installation recommendation

TSS Dash Sizes	Bore Diameter		Groove Diameter	Groove Width	Groove Width	Radius	Radial Clearance			O-Ring Cross-Sec.
	DN H9						S max.			
	Standard Application	Light Application	d1 h9	L1 +.008	L2 +.008	r1	10 MPa 1500 psi	20 MPa 3000 psi	40 MPa 5800 psi	d2
006 - 028	.250 - .281	.312 - 1.500	DN -.110	.093	.138	.005	.004	.003	.002	.070
104 - 149	.312 - .406	.437 - 3.000	DN -.176	.140	.171	.005	.006	.004	.003	.103
201 - 248	.437 - .750	.812 - 5.000	DN -.242	.187	.208	.010	.008	.006	.003	.139
309 - 350	.812 - 4.875	5.000	DN -.370	.281	.311	.020	.010	.008	.004	.210
425 - 460	5.000 - 16.000	-	DN -.474	.375	.408	.020	.012	.010	.006	.275

L1 is for "0" Back-up groove width - PD00_B series

L2 is for "1" Back-up groove width - PD01_B series



Ordering example

Turcon® Double Delta®, complete with O-Ring, standard range, series PD00 (from Table XXX)

Dash size: 117

TSS Part No.: PD000B117 (from Table XXXI)

Select the material from Table XXIX. The corresponding code numbers are appended to the TSS Part No. (from Table XXXI). Together they form the TSS Article No.

For all intermediate sizes not shown in Table XXXI, the TSS Article No. can be determined from the example opposite.

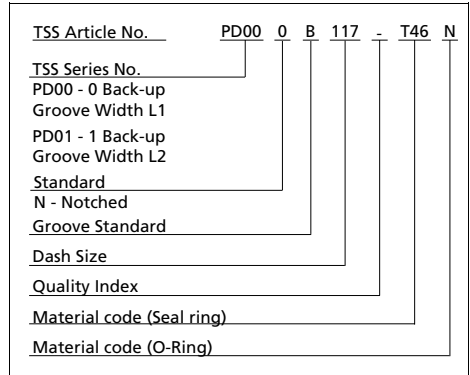

Notes:

- 1) Tolerances used are per ISO-286; ISO System of Limits and Fits. The tolerances are converted from metric and rounded to the nearest three place decimal.
- 2) The clearance stated as S in the table XXX is for when the seal is specified with Slydring bearings. When not incorporating Slydring bearings, the diametral clearance should be reduced.

Table XXXI Installation dimensions/TSS Part No.

Bore Diameter	Groove Diameter	Groove Width	TSS Part No.	Groove Width	TSS Part No.
D_N H9	d₁ h9	L₁ +.008		L₂ +.008	
.250	.140	.093	PD000B006	.138	PD010B006
.281	.171	.093	PD000B007	.138	PD010B007
.312	.202	.093	PD000B008	.138	PD010B008
.344	.234	.093	PD000B009	.138	PD010B009
.375	.265	.093	PD000B010	.138	PD010B010
.437	.327	.093	PD000B011	.138	PD010B011
.500	.390	.093	PD000B012	.138	PD010B012
.563	.452	.093	PD000B013	.138	PD010B013
.625	.515	.093	PD000B014	.138	PD010B014
.688	.577	.093	PD000B015	.138	PD010B015
.750	.640	.093	PD000B016	.138	PD010B016
.813	.702	.093	PD000B017	.138	PD010B017
.875	.765	.093	PD000B018	.138	PD010B018
.938	.827	.093	PD000B019	.138	PD010B019
1.000	.824	.140	PD000B117	.171	PD010B117

The sizes listed in **bold** font are preferred sizes (more likely to be available for immediate shipment). Other dimensions and all intermediate sizes up to 102 inches (2600mm) diameter can be supplied.



Turcon® Double Delta®

Bore Diameter	Groove Diameter	Groove Width	TSS Part No.	Groove Width	TSS Part No.
D _N H9	d ₁ h9	L ₁ +.008		L ₂ +.008	
1.063	.886	.140	PD000B118	.171	PD010B118
1.125	.949	.140	PD000B119	.171	PD010B119
1.188	1.011	.140	PD000B120	.171	PD010B120
1.250	1.074	.140	PD000B121	.171	PD010B121
1.313	1.136	.140	PD000B122	.171	PD010B122
1.375	1.199	.140	PD000B123	.171	PD010B123
1.438	1.261	.140	PD000B124	.171	PD010B124
1.500	1.324	.140	PD000B125	.171	PD010B125
1.563	1.386	.140	PD000B126	.171	PD010B126
1.625	1.449	.140	PD000B127	.171	PD010B127
1.688	1.511	.140	PD000B128	.171	PD010B128
1.750	1.574	.140	PD000B129	.171	PD010B129
1.813	1.636	.140	PD000B130	.171	PD010B130
1.875	1.699	.140	PD000B131	.171	PD010B131
1.938	1.761	.140	PD000B132	.171	PD010B132
2.000	1.824	.140	PD000B133	.171	PD010B133
2.063	1.886	.140	PD000B134	.171	PD010B134
2.125	1.949	.140	PD000B135	.171	PD010B135
2.188	2.011	.140	PD000B136	.171	PD010B136
2.250	2.074	.140	PD000B137	.171	PD010B137
2.313	2.136	.140	PD000B138	.171	PD010B138
2.375	2.199	.140	PD000B139	.171	PD010B139
2.438	2.261	.140	PD000B140	.171	PD010B140
2.500	2.324	.140	PD000B141	.171	PD010B141
2.625	2.383	.187	PD000B229	.208	PD010B229
2.750	2.508	.187	PD000B230	.208	PD010B230
2.875	2.633	.187	PD000B231	.208	PD010B231
3.000	2.758	.187	PD000B232	.208	PD010B232
3.125	2.883	.187	PD000B233	.208	PD010B233
3.250	3.008	.187	PD000B234	.208	PD010B234
3.375	3.133	.187	PD000B235	.208	PD010B235
3.500	3.258	.187	PD000B236	.208	PD010B236
3.625	3.383	.187	PD000B237	.208	PD010B237
3.750	3.508	.187	PD000B238	.208	PD010B238
3.875	3.633	.187	PD000B239	.208	PD010B239
4.000	3.758	.187	PD000B240	.208	PD010B240

The sizes listed in **bold** font are preferred sizes (more likely to be available for immediate shipment). Other dimensions and all intermediate sizes up to 102 inches (2600mm) diameter can be supplied.





Bore Diameter	Groove Diameter	Groove Width	TSS Part No.	Groove Width	TSS Part No.
D_N H9	d₁ h9	L₁ +.008		L₂ +.008	
4.125	3.883	.187	PD000B241	.208	PD010B241
4.250	4.008	.187	PD000B242	.208	PD010B242
4.375	4.133	.187	PD000B243	.208	PD010B243
4.500	4.258	.187	PD000B244	.208	PD010B244
4.625	4.383	.187	PD000B245	.208	PD010B245
4.750	4.508	.187	PD000B246	.208	PD010B246
4.875	4.633	.187	PD000B247	.208	PD010B247
5.000	4.526	.375	PD000B425	.408	PD010B425
5.125	4.651	.375	PD000B426	.408	PD010B426
5.250	4.776	.375	PD000B427	.408	PD010B427
5.375	4.901	.375	PD000B428	.408	PD010B428
5.500	5.026	.375	PD000B429	.408	PD010B429
5.625	5.151	.375	PD000B430	.408	PD010B430
5.750	5.276	.375	PD000B431	.408	PD010B431
5.875	5.401	.375	PD000B432	.408	PD010B432
6.000	5.526	.375	PD000B433	.408	PD010B433
6.125	5.651	.375	PD000B434	.408	PD010B434
6.250	5.776	.375	PD000B435	.408	PD010B435
6.375	5.901	.375	PD000B436	.408	PD010B436
6.500	6.026	.375	PD000B437	.408	PD010B437
6.750	6.276	.375	PD000B438	.408	PD010B438
7.000	6.526	.375	PD000B439	.408	PD010B439
7.250	6.776	.375	PD000B440	.408	PD010B440
7.500	7.026	.375	PD000B441	.408	PD010B441
7.750	7.276	.375	PD000B442	.408	PD010B442
8.000	7.526	.375	PD000B443	.408	PD010B443
8.250	7.776	.375	PD000B444	.408	PD010B444
8.500	8.026	.375	PD000B445	.408	PD010B445

The sizes listed in **bold** font are preferred sizes (more likely to be available for immediate shipment). Other dimensions and all intermediate sizes up to 102 inches (2600mm) diameter can be supplied.



Turcon® Double Delta®

TURCON[®] CST SEAL

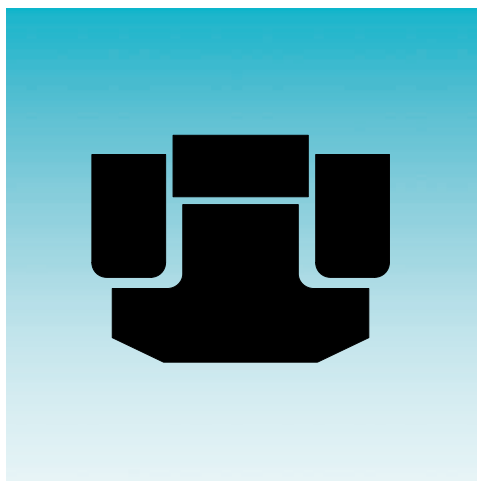

- Double-Acting -
- Elastomer-Energized Turcon[®] Slipper Seal -

- Material -
- Turcon[®] and POM -





■ Turcon® CST Seal

Description

The CST Seal is a high-pressure heavy-duty piston seal with excellent leakage control and superior extrusion and wear resistance

The CST seal is a combination of a Turcon®-based slipper seal energized by an elastomer profile ring and completed with two Back-up rings (Zurcon®). It is manufactured with a predefined interference fit, which together with the squeeze of the elastomer part ensures a good sealing effect even at low system pressure. At higher pressures the elastomer part is energized by the system pressure and activates the slipper seal in the radial direction.

The back-up rings prevent the slipper seal from extrusion and ensure a long service life even under harsh conditions.

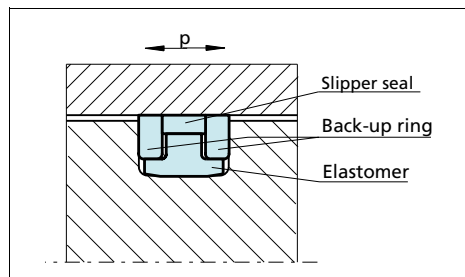

Figure 40 CST Seal

Advantages

- Simple groove design
- No stick-slip effect when starting for smooth operation
- Minimum static and dynamic coefficient of friction
- Increased clearance possible
- Due to larger extrusion gap, safe use even with soiled media
- Long service life

Application Examples

The CST Seal is the recommended sealing element for double-acting pistons of hydraulic cylinders working in very harsh conditions such as:

- Excavators
- Heavy duty hydraulic cylinders

Technical Data

Operating conditions

Pressure:	Up to 11,600 psi (80 MPa) Peak pressure up to 19,500 psi (135 MPa)
Velocity:	Up to 5 ft/s (1.5 m/s)
Temperature:	-49°F to +275°F (-45°C to +135°C)
Media:	Mineral oil based hydraulic fluids, water/oil and glycol/oil emulsions
Clearance:	The maximum permissible radial clearance S_{max} is shown in Table XXXV, as a function of the operating pressure and functional diameter.

Materials

Standard Application:

For hydraulic components:

- In mineral oils or medium with good lubricating performance

Seal ring:	Turcon®T46
Energizer:	Turel®NP
Back-up rings:	Zurcon®Z60
Material code for the set:	T46NP

Special Application:

- For special applications requiring other material combinations, please contact your local Trelleborg Sealing Solutions sales office.



Turcon® CST Seal

Table XXXIII Turcon® Materials for Turcon® CST Seal®

Material, Applications, Properties	Code	Engisier Material	Code	Engisier Operating Temp.* °F	Mating Surface Material	PSI max.
Turcon® T46 Standard material for hydraulics, high compressive strength, good sliding and wear properties, good extrusion resistance, BAM tested. Bronze-filled Color: Grayish to dark brown	T46	NBR-70 Shore A	N	-22 to +212	Steel tube Steel, hardened Cast iron	7,500
		NBR-Low temp. 70 Shore A	T	-49 to +176		
		FKM-70 Shore A	V	-14 to +392		
Turcon® T29 For all lubricating and non-lubricating hydraulic fluids, hydraulic oils without zinc, soft mating surfaces, good extrusion resistance. Surface texture not suitable for gases. High carbon fiber-filled Color: Gray	T29	NBR-70 Shore A	N	-22 to +212	Steel Cast iron Stainless steel Aluminium Bronze	7,500
		NBR-Low temp. 70 Shore A	T	-49 to +176		
		FKM-70 Shore A	V	-14 to +392		
		EPDM-70 Shore A	E**	-49 to +293		
Turcon® T42 For all lubricating and non-lubricating hydraulic fluids, good chemical resistance, good dielectric properties. Glass fiber-filled + MoS ₂ Color: Gray to blue	T42	NBR-70 Shore A	N	-22 to +212	Steel tube Steel, hardened Cast iron	5,800
		NBR-Low temp. 70 Shore A	T	-49 to +176		
		FKM-70 Shore A	V	-14 to +392		

* The O-Ring operation temperature is only valid in mineral hydraulic oil. ** Material not suitable for mineral oils.
 BAM: Tested by "Bundes Anstalt Materialprüfung, Germany". Highlighted materials are standard.



■ Installation Recommendation

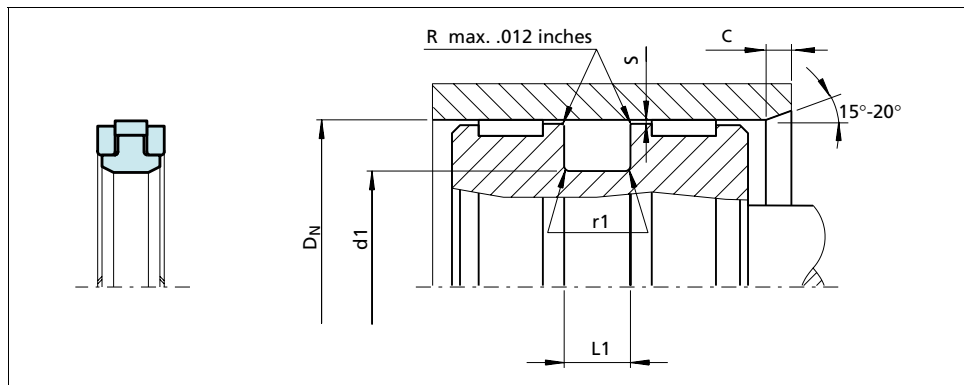

Figure 41 Installation drawing

- 1) The bore diameter H9 tolerance is recommended per ISO-286; ISO System of Limits and Fits. The tolerances are converted from metric and rounded to the nearest three place decimal.
- 2) The groove diameter h9 tolerance is recommended per ISO-286; ISO System of Limits and Fits. The tolerances are converted from metric and rounded to the nearest three place decimal.
- 3) The clearances stated as S in the above table are for the Turcon® CST Seal when specified with Slydring® bearings. When not incorporating Slydring® bearings, the diametral clearance should be reduced.
- 4) To determine minimum piston diameter D, subtract diametral clearance from the maximum bore.
- 5) Consult your sales office for diameters that exceed those listed in the above table.

Table XXXIV Installation recommendation

TSS Series No.	Bore Diameter			Groove Diameter	Groove Width	Radius	Radial Clearance	
	D _N H9						d ₁ h9	L ₁ +.010
	Standard	Light Application	Heavy Duty	35 MPa 5000 psi	45 MPa 6500 psi			
PK07	1.000 - 2.999	-	-	D _N - .373	.424	.020	.012	.009
PK08	3.000 - 4.999	-	-	D _N - .478	.579	.025	.018	.010
PK09	5.000 - 20.000	-	-	D _N - .726	.750	.035	.019	.012



Turcon® CST Seal

Ordering Example

CST Seal, complete

Bore diameter: $D_N = 4.000$ inches
 TSS Part No.: PK0804000 (from Table XXXV)
 Seal: Turcon® T46
 Energizer: Turel® NP
 Back-up ring: Zurcon® Z60

Material set-code: T46N

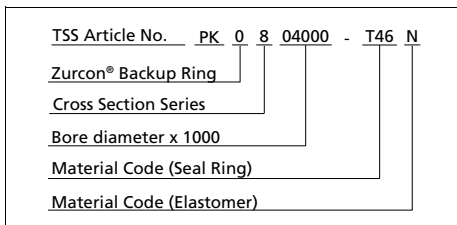

Table XXXV Installation dimensions / TSS Part No.

Bore Diameter	Groove Diameter	Groove Width	TSS Part No.
D_N H9	d_1 h9	L_1 +.010	
1.000	.627	.424	PK0701000
1.063	.690	.424	PK0701063
1.125	.752	.424	PK0701125
1.188	.815	.424	PK0701188
1.250	.877	.424	PK0701250
1.313	.940	.424	PK0701313
1.375	1.002	.424	PK0701375
1.438	1.065	.424	PK0701438
1.500	1.127	.424	PK0701500
1.563	1.190	.424	PK0701563
1.625	1.252	.424	PK0701625
1.688	1.315	.424	PK0701688
1.750	1.377	.424	PK0701750
1.813	1.440	.424	PK0701813
1.875	1.502	.424	PK0701875
1.938	1.565	.424	PK0701938
2.000	1.627	.424	PK0702000
2.125	1.752	.424	PK0702125
2.250	1.877	.424	PK0702250
2.375	2.002	.424	PK0702375
2.500	2.127	.424	PK0702500
2.625	2.252	.424	PK0702625
2.750	2.377	.424	PK0702750
2.875	2.502	.424	PK0702875
3.000	2.522	.579	PK0803000
3.125	2.647	.579	PK0803125
3.250	2.772	.579	PK0803250

Bore Diameter	Groove Diameter	Groove Width	TSS Part No.
D_N H9	d_1 h9	L_1 +.010	
3.375	2.897	.579	PK0803375
3.500	3.022	.579	PK0803500
3.625	3.147	.579	PK0803625
3.750	3.272	.579	PK0803750
3.875	3.397	.579	PK0803875
4.000	3.522	.579	PK0804000
4.125	3.647	.579	PK0804125
4.250	3.772	.579	PK0804250
4.375	3.897	.579	PK0804375
4.500	4.022	.579	PK0804500
4.625	4.147	.579	PK0804625
4.750	4.272	.579	PK0804750
4.875	4.397	.579	PK0804875
5.000	4.274	.750	PK0905000
5.125	4.399	.750	PK0905125
5.250	4.524	.750	PK0905250
5.375	4.649	.750	PK0905375
5.500	4.774	.750	PK0905500
5.625	4.899	.750	PK0905625
5.750	5.024	.750	PK0905750
5.875	5.149	.750	PK0905875
6.000	5.274	.750	PK0906000
6.250	5.524	.750	PK0906250
6.500	5.774	.750	PK0906500
6.750	6.024	.750	PK0906750
7.000	6.274	.750	PK0907000
7.250	6.524	.750	PK0907250



Bore Diameter	Groove Diameter	Groove Width	TSS Part No.
D _N H9	d ₁ h9	L ₁ +.010	
7.500	6.774	.750	PK0907500
7.750	7.024	.750	PK0907750
8.000	7.274	.750	PK0908000
8.250	7.524	.750	PK0908250
8.500	7.774	.750	PK0908500
8.750	8.024	.750	PK0908750
9.000	8.274	.750	PK0909000
9.250	8.524	.750	PK0909250
9.500	8.774	.750	PK0909500
9.750	9.024	.750	PK0909750
10.000	9.274	.750	PK0910000
10.500	9.774	.750	PK0910500
11.000	10.274	.750	PK0911000
11.500	10.774	.750	PK0911500
12.000	11.274	.750	PK0912000
12.500	11.774	.750	PK0912500
13.000	12.274	.750	PK0913000
13.500	12.774	.750	PK0913500
14.000	13.274	.750	PK0914000
14.500	13.774	.750	PK0914500
15.000	14.274	.750	PK0915000
15.500	14.774	.750	PK0915500
16.000	15.274	.750	PK0916000
16.500	15.774	.750	PK0916500
17.000	16.274	.750	PK0917000
17.500	16.774	.750	PK0917500
18.000	17.274	.750	PK0918000
18.500	17.774	.750	PK0918500
19.000	18.274	.750	PK0919000
19.500	18.774	.750	PK0919500
20.000	19.274	.750	PK0920000

The sizes listed in **bold** font are preferred sizes (more likely to be available for immediate shipment). Other dimensions and all intermediate sizes up to 106 inches (2700mm) diameter can be supplied.



Turcon® CST Seal

TURCON[®] AQ-SEAL[®]

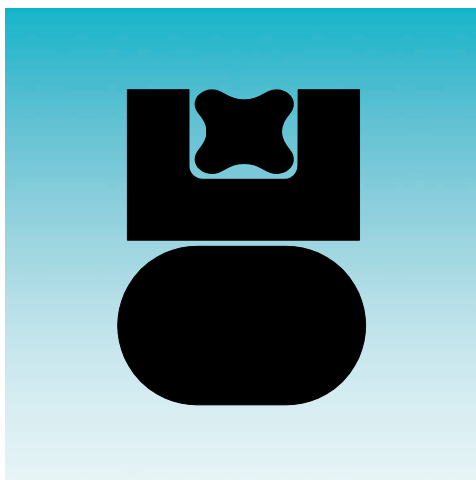

- Double-Acting -
- O-Ring-Energized Slipper Seal Elastomer Contact -

- Material -
- Turcon[®] and Elastomer -





■ Turcon® AQ-Seal®

Description

The Turcon® AQ-Seal® is a double-acting seal consisting of a seal ring of high-grade modified Turcon® material, an X-ring Seal and an O-Ring as an energizing element.

The Turcon® seal ring and the X-ring Seal together assume the dynamic sealing function while the O-Ring performs the static sealing function.

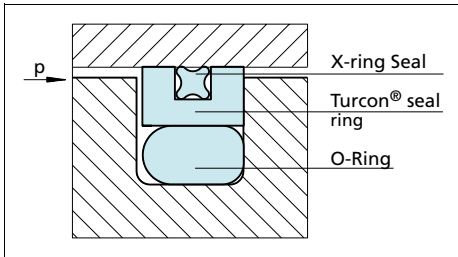

Figure 42 Turcon® AQ-Seal®

Advantages

- High sealing effect in applications requiring media separation, e.g. fluid/fluid or fluid/gas
- Double security through the combination of low-friction special materials with elastomer seals
- Simple groove design, small installation space, interchangeable with Turcon® Glyd Ring®, Turcon® Glyd Ring® T and Turcon® Stepseal® K installation according to ISO 7425/1
- Outstanding sliding properties, no stick-slip effect

Application Examples

The Turcon® AQ-Seal® is the recommended sealing element for double-acting pistons of accumulators and positioning and holding cylinders for:

- Machine tools
- Presses
- Accumulators
- Stabilizers
- Heavy duty suspension cylinders

Technical Data

Operating pressure:	5,800 psi (40 MPa)
Velocity:	Up to 6.5 ft/s (2 m/s)
Temperature:	-49°F to +392°F (-45°C to +200°C *) (depending on O-Ring and X-ring Seal material) (For applications at low temperatures below -22°F (-30°C), please contact us).
Media:	For all common hydraulic fluids, including bio-oils and gases
Clearance:	The maximum permissible radial clearance S_{max} is shown in Table XXXVII, as a function of the operating pressure and functional diameter.

Important Note:

The above data are maximum values and cannot be used at the same time. e.g. the maximum operating speed depends on material type, pressure, temperature and gap value. Temperature range also dependent on medium.

*) In the case of unpressurized applications in temperatures below 32 °F (0 °C) please contact our application engineers for assistance!



Materials

Standard Application:

- For hydraulic components in mineral oils or medium with good lubricating performance
- Mineral oils and gases

Seal ring: Turcon® T46

Energizer: O-Ring and X-ring Seal in NBR 70 Shore A (code N)

Special Application:

- For special applications requiring other material combinations, please contact your local Trelleborg Sealing Solutions sales office.

Table XXXVI Turcon® Materials for Turcon® AQ-Seal®

Material, Applications, Properties	Code	O-Ring Material	Code	O-Ring Operating Temp.* °F	Mating Surface Material	PSI Max.
Turcon® T46 Standard material for hydraulics, high compressive strength, good sliding and wear properties, good extrusion resistance, BAM tested. Bronze-filled Color: grayish to dark brown	T46	NBR - 70 Shore A	N	-22 to +212	Steel tubes Steel, hardened Cast iron	5,800
		NBR - Low temp. 70 Shore A	T	-49 to +176		
		FKM - 70 Shore A	V	-14 to +392		
Turcon® T40 For all lubricating and non-lubricating hydraulic fluids, hydraulic oils without zinc, water hydraulic, soft mating surfaces. Surface texture not suitable for gases. Carbon fiber-filled Color: gray	T40	NBR - 70 Shore A	N	-22 to +212	Steel Cast iron Stainless steel, Aluminium Bronze Alloys	3,625
		NBR - Low temp. 70 Shore A	T	-49 to +176		
		FKM - 70 Shore A	V	-14 to +392		
		EPDM-70 Shore A	E**	-49 to +293		
Turcon® T10 For oil hydraulic and pneumatic for all lubricating and non-lubricating fluids, high extrusion resistance, good chemical resistance, BAM tested. Carbon, graphite-filled Color: black	T10	NBR - 70 Shore A	N	-22 to +212	Steel Stainless steel	5,800
		NBR - Low temp. 70 Shore A	T	-49 to +176		
		FKM - 70 Shore A	V	-14 to +392		
		EPDM-70 Shore A	E**	-49 to +293		

* The O-Ring operation temperature is only valid in mineral hydraulic oil. ** Material not suitable for mineral oils.
 BAM: Tested by "Bundes Anstalt Materialprüfung, Germany". Highlighted materials are standard.



■ Installation Recommendation (Inch Piston Series)

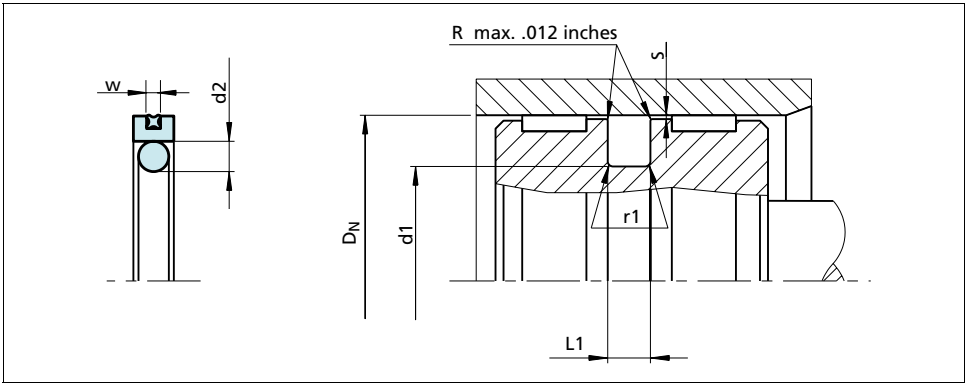

Figure 43 Installation drawing

Table XXXVII Installation recommendation

Bore Diameter D _N H9				Groove Diameter	Groove Width	Rad. r ₁	Radial Clearance S max			O-Ring Cross Section	X-Ring Cross Section
Standard Application		Light Application					10 MPa 1500 psi	20 MPa 3000 psi	40 MPa 5800 psi		
TSS Series No.	Diameter Range	TSS Series No.	Diameter Range	d ₁ h9	L ₁ +.008	r ₁				d ₂	W
PQE0	.625 - 1.563	PQE4	1.564 - 3.125	D _N - .433	.165	.040	.010	.006	.004	.139	.070
PQE0	1.564 - 3.125	PQE4	3.126 - 5.250	D _N - .610	.248	.050	.012	.008	.006	.210	.070
PQE1	3.126 - 5.250	PQE5	5.251 - 9.975	D _N - .827	.319	.070	.012	.008	.006	.275	.103
PQE1	5.251 - 9.975	-	-	D _N - .965	.319	.070	.012	.008	.006	.275	.103
PQE2	9.976 - 18.225	-	-	D _N - 1.102	.374	.100	.018	.012	.010	.330	.139
PQE3	18.226 - 27.500	-	-	D _N - 1.378	.453	.120	.022	.016	.014	.394	.139



Ordering example

Turcon® AQ-Seal®, complete with O-Ring and X-Ring Seal, recommended range, Series PQE1 (from Table XXXVII)

Bore diameter: $D_N = 4.000$ inches
 TSS Part No. PQE104000 (from Table XXXVIII)

Select the material from Table XXXVI. The corresponding code numbers are appended to the TSS Part No. (from Table XXXVIII). Together they form the TSS Article No. For all intermediate sizes not shown in Table XXXVIII, the TSS Article No. can be determined from the example opposite.

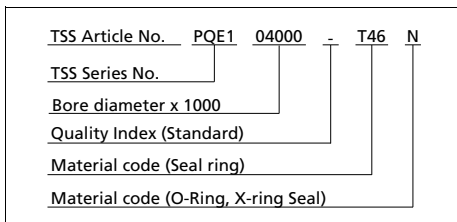

Table XXXVIII Installation dimensions / TSS Part No

Bore Diameter	Groove Diameter	Groove Width	TSS Part No.
D_N H9	d_1 h9	$L_1 +.010$	
1.500	1.067	.165	PQE001500
1.563	1.130	.165	PQE001563
1.625	1.192	.165	PQE401625
1.688	1.255	.165	PQE401688
1.750	1.317	.165	PQE401750
1.813	1.380	.165	PQE401813
1.875	1.442	.165	PQE401875
1.938	1.505	.165	PQE401938
2.000	1.567	.165	PQE402000
2.125	1.692	.165	PQE402125
2.250	1.817	.165	PQE402250
2.375	1.942	.165	PQE402375
2.500	2.067	.165	PQE402500
2.625	2.192	.165	PQE402625
2.750	2.317	.165	PQE402750
2.875	2.442	.165	PQE402875
3.000	2.567	.165	PQE403000
3.125	2.692	.165	PQE403125
3.250	2.640	.248	PQE403250
3.375	2.765	.248	PQE403375
3.500	2.890	.248	PQE403500
3.625	3.015	.248	PQE403625
3.750	3.140	.248	PQE403750
3.875	3.265	.248	PQE403875

Bore Diameter	Groove Diameter	Groove Width	TSS Part No.
D_N H9	d_1 h9	$L_1 +.010$	
4.000	3.390	.248	PQE404000
4.125	3.515	.248	PQE404125
4.250	3.640	.248	PQE404250
4.375	3.765	.248	PQE404375
4.500	3.890	.248	PQE404500
4.625	4.015	.248	PQE404625
4.750	4.140	.248	PQE404750
4.875	4.265	.248	PQE404875
5.000	4.390	.248	PQE405000
5.125	4.515	.248	PQE405125
5.250	4.640	.248	PQE405250
5.375	4.548	.319	PQE505375
5.500	4.673	.319	PQE505500
5.625	4.798	.319	PQE505625
5.750	4.923	.319	PQE505750
6.000	5.173	.319	PQE506000
6.250	5.423	.319	PQE506250
6.500	5.673	.319	PQE506500
6.750	5.923	.319	PQE506750
7.000	6.173	.319	PQE507000
7.250	6.423	.319	PQE507250
7.500	6.673	.319	PQE507500
7.750	6.923	.319	PQE507750
8.000	7.173	.319	PQE508000





Bore Diameter	Groove Diameter	Groove Width	TSS Part No.
D_N H9	d_1 h9	L_1 +.010	
8.250	7.423	.319	PQE508250
8.500	7.673	.319	PQE508500
8.750	7.923	.319	PQE508750
9.000	8.173	.319	PQE509000
9.250	8.423	.319	PQE509250
9.500	8.673	.319	PQE509500
9.750	8.923	.319	PQE509750
10.000	8.898	.374	PQE210000
10.500	9.398	.374	PQE210500
11.000	9.898	.374	PQE211000
11.500	10.398	.374	PQE211500
12.000	10.898	.374	PQE212000
12.500	11.398	.374	PQE212500
13.000	11.898	.374	PQE213000
13.500	12.398	.374	PQE213500
14.000	12.898	.374	PQE214000
14.500	13.398	.374	PQE214500
15.000	13.898	.374	PQE215000
15.500	14.398	.374	PQE215500
16.000	14.898	.374	PQE216000
16.500	15.398	.374	PQE216500
17.000	15.898	.374	PQE217000
17.500	16.398	.374	PQE217500
18.000	16.898	.374	PQE218000
18.500	17.122	.453	PQE318500
19.000	17.622	.453	PQE319000
19.500	18.122	.453	PQE319500
20.000	18.622	.453	PQE320000

The sizes listed in **bold** font are preferred sizes (more likely to be available for immediate shipment). Other dimensions and all intermediate sizes up to 100 inches (2540 mm) diameter can be supplied.



TURCON[®] AQ-SEAL[®] 5



- Double-Acting -
- O-Ring-Energized Slipper Seal Elastomer Contact -

- Material -
- Turcon[®] and Elastomer -





■ Turcon® AQ-Seal® 5

Description

The Turcon® AQ-Seal® 5 is a patented development of the proven standard Turcon® AQ-Seal®.

The seal profile of the Turcon® ring has been redesigned on both the dynamic and static sealing surfaces. Two O-Rings are used to energize the seal instead of one.

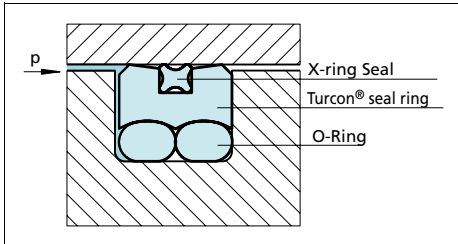

Figure 44 Turcon® AQ-Seal® 5

The AQ-Seal® 5 combines the benefits of a low-friction Turcon® slipper seal with the high sealing characteristics of an elastomeric seal by incorporating a limited foot print X-ring Seal in the dynamic sealing face. This optimizes leakage control while minimizing friction.

The unique characteristics of the AQ-Seal® 5 are the special seal profile with a defined seal edge and the use of two O-Rings as energizing elements to optimize the pressure profile and to reduce the force of attack at gas permeability.

Advantages

- High sealing effect in applications requiring media separation, e.g. fluid/fluid or fluid/gas
- Double security through the combination of low-friction special materials with elastomer seals
- Low gas permeation rate
- Higher pressure application, higher sliding speed compared to the AQ-Seal®
- Outstanding sliding properties, no stick-slip effect

Application Examples

The Turcon® AQ-Seal® 5 is the recommended sealing element for double acting pistons of accumulators and positioning and holding cylinders for:

- Machine tools
- Presses
- Rolling mills
- Offshore
- Accumulators
- Heavy duty suspension cylinders

It is particularly recommended for heavy duty and large diameter applications.

Technical Data

Operating conditions

- Pressure: 8,700 psi (60 MPa)
- Velocity: Up to 10 ft/s (3 m/s)
- Temperature: -22°F to +392°F (-30°C to +200°C)**
(depending on O-Ring and X-ring Seal material)
(For applications at low temperatures below -22°F (-30°C), please contact us).
- Media: For all common hydraulic fluids, including bio-oils and gases
- Clearance: The maximum permissible radial clearance S_{max} is shown in Table XL, as a function of the operating pressure and functional diameter.

Important Note:

The above data are maximum values and cannot be used at the same time. e.g. the maximum operating speed depends on material type, pressure, temperature and gap value. Temperature range also dependent on medium.

***) in the case of unpressurized applications in temperatures below 32 °F (0 °C) please contact our application engineers for assistance!



Turcon® AQ-Seal® 5

Materials

Standard Application:

- For hydraulic components in mineral oils or medium with good lubricating performance
- Mineral oils and gases

Seal ring: Turcon® T46

Energizer: O-Ring and X-ring seal in NBR 70 Shore A (code N)

Special Application:

- For special applications requiring other material combinations, please contact your local Trelleborg Sealing Solutions sales office.

Table XXXIX Turcon® Materials for Turcon® AQ-Seal® 5

Material, Applications, Properties	Code	O-Ring Material	Code	O-Ring Operating Temp.* °F	Mating Surface Material	PSI Max.
Turcon® T46 Standard material for hydraulics, high compressive strength, good sliding and wear properties, good extrusion resistance, BAM tested. Bronze-filled Color: grayish to dark brown	T46	NBR - 70 Shore A	N	-22 to +212	Steel tubes Steel, hardened Cast iron	8,700
		FKM - 70 Shore A	V	-14 to +392		
Turcon® T40 For all lubricating and non-lubricating hydraulic fluids, hydraulic oils without zinc, water hydraulic, soft mating surfaces. Surface texture not suitable for gases. Carbon fiber-filled Color: gray	T40	NBR - 70 Shore A	N	-22 to +212	Steel Cast iron Stainless steel, Aluminium Bronze Alloys	3,625
		FKM - 70 Shore A	V	-14 to +392		
		EPDM-70 Shore A	E**	-49 to +293		
Turcon® T10 For oil hydraulic and pneumatic for all lubricating and non-lubricating fluids, high extrusion resistance, good chemical resistance, BAM tested. Carbon, graphite-filled Color: black	T10	NBR - 70 Shore A	N	-22 to +212	Steel Stainless steel	8,700
		FKM - 70 Shore A	V	-14 to +392		
		EPDM-70 Shore A	E**	-49 to +293		

* The O-Ring operation Temperature is only valid in mineral hydraulic oil. ** Material not suitable for mineral oils.
 BAM: Tested by "Bundes Anstalt Materialprüfung, Germany". Highlighted materials are standard.



■ Installation Recommendation (Inch Piston Series)

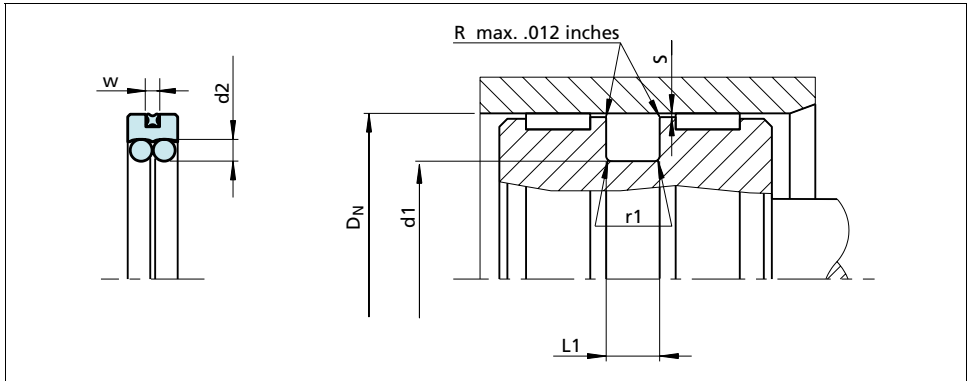

Figure 45 Installation drawing

Table XL Installation recommendation

TSS Series No.	Bore Diameter		Groove Diameter	Groove Width	Radius	Radial Clearance		O-Ring Cross-Section	X-Ring Cross-Section
	D _N H9					S max.*			
	Standard Application	Light Application					10 MPa 1500 psi		
PQ41	1.500 - 2.999	3.000 - 5.500	D _N - .394	.248	.005	.012	.009	.103	.070
PQ42	3.000 - 4.999	5.000 - 10.000	D _N - .512	.326	.010	.013	.010	.139	.103
PQ43	5.000 - 11.999	12.000 - 19.000	D _N - .709	.484	.015	.014	.011	.210	.139
PQ44	12.000 - 26.000	-	D _N - 1.220	.642	.015	.016	.013	.275	.210

* At pressures > 30 MPa (4,350 psi) use diameter tolerance H8/f8 (bore/piston) in area of the seal. The clearances stated as S in the above table are for the Turcon® AQ-Seal® 5 when specified with Slydring® bearings, the diametral clearance should be reduced.

Ordering example

Turcon®AQ-Seal®5, complete with O-Ring and X-Ring Seal, recommended range, Series PQ41 (from Table XLI)

Bore diameter: D_N = 2.000 inches
TSS Part No. PQ4102000 (from Table XLI)

Select the material from Table XXXIX. The corresponding code numbers are appended to the TSS Part No. (from Table XLI). Together they form the TSS Article No. For all intermediate sizes not shown in Table XLI, the TSS Article No. can be determined from the example opposite.

TSS Article No.	PQ41	02000	-	T46	N
TSS Series No.					
Bore diameter x 1000					
Material code (Seal ring)					
Material code (O-Ring, X-ring Seal)					

*** For diameters ≥ 100 inches please consult your Trelleborg Sealing Solutions sales office for special part no.



Table XLI Installation dimensions / TSS Part No.

Bore Diameter	Groove Diameter	Groove Width	TSS Part No.
D _N H9	d ₁ h9	L ₁ +.010	
1.500	1.106	.248	PQ4101500
1.563	1.169	.248	PQ4101563
1.625	1.231	.248	PQ4101625
1.688	1.294	.248	PQ4101688
1.750	1.356	.248	PQ4101750
1.813	1.419	.248	PQ4101813
1.875	1.481	.248	PQ4101875
1.938	1.544	.248	PQ4101938
2.000	1.606	.248	PQ4102000
2.125	1.731	.248	PQ4102125
2.250	1.856	.248	PQ4102250
2.375	1.981	.248	PQ4102375
2.500	2.106	.248	PQ4102500
2.625	2.231	.248	PQ4102625
2.750	2.356	.248	PQ4102750
2.875	2.481	.248	PQ4102875
3.000	2.488	.326	PQ4203000
3.125	2.613	.326	PQ4203125
3.250	2.738	.326	PQ4203250
3.375	2.863	.326	PQ4203375
3.500	2.988	.326	PQ4203500
3.625	3.113	.326	PQ4203625
3.750	3.238	.326	PQ4203750
3.875	3.363	.326	PQ4203875
4.000	3.488	.326	PQ4204000
4.125	3.613	.326	PQ4204125
4.250	3.738	.326	PQ4204250
4.375	3.863	.326	PQ4204375
4.500	3.988	.326	PQ4204500
4.625	4.113	.326	PQ4204625
4.750	4.238	.326	PQ4204750
4.875	4.363	.326	PQ4204875
5.000	4.291	.484	PQ4305000
5.125	4.416	.484	PQ4305125
5.250	4.541	.484	PQ4305250
5.375	4.666	.484	PQ4305375

Bore Diameter	Groove Diameter	Groove Width	TSS Part No.
D _N H9	d ₁ h9	L ₁ +.010	
5.500	4.791	.484	PQ4305500
5.625	4.916	.484	PQ4305625
5.750	5.041	.484	PQ4305750
5.875	5.166	.484	PQ4305875
6.000	5.291	.484	PQ4306000
6.250	5.541	.484	PQ4306250
6.500	5.791	.484	PQ4306500
6.750	6.041	.484	PQ4306750
7.000	6.291	.484	PQ4307000
7.250	6.541	.484	PQ4307250
7.500	6.791	.484	PQ4307500
7.750	7.041	.484	PQ4307750
8.000	7.291	.484	PQ4308000
8.250	7.541	.484	PQ4308250
8.500	7.791	.484	PQ4308500
8.750	8.041	.484	PQ4308750
9.000	8.291	.484	PQ4309000
9.250	8.541	.484	PQ4309250
9.500	8.791	.484	PQ4309500
9.750	9.041	.484	PQ4309750
10.000	9.291	.484	PQ4310000
10.500	9.791	.484	PQ4310500
11.000	10.291	.484	PQ4311000
11.500	10.791	.484	PQ4311500
12.000	10.780	.642	PQ4412000
12.500	11.280	.642	PQ4412500
13.000	11.780	.642	PQ4413000
13.500	12.280	.642	PQ4413500
14.000	12.780	.642	PQ4414000
14.500	13.280	.642	PQ4414500
15.000	13.780	.642	PQ4415000
15.500	14.280	.642	PQ4415500
16.000	14.780	.642	PQ4416000
16.500	15.280	.642	PQ4416500
17.000	15.780	.642	PQ4417000
17.500	16.280	.642	PQ4417500





Bore Diameter	Groove Diameter	Groove Width	TSS Part No.
D_N H9	d_1 h9	L_1 +.010	
18.000	16.780	.642	PQ4418000
18.500	17.280	.642	PQ4418500
19.000	17.780	.642	PQ4419000
19.500	18.280	.642	PQ4419500
20.000	18.780	.642	PQ4420000

The sizes listed in **bold** font are preferred sizes (more likely to be available for immediate shipment). Other dimensions and all intermediate sizes up to 100 inches (2540 mm) diameter can be supplied.



Turcon® AQ-Seal® 5

TURCON[®] VARISEAL[®] M2

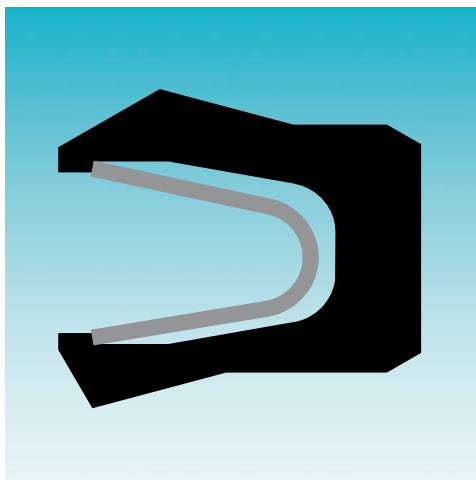

- Single-Acting -
- Spring-Energized Turcon[®] U-Cup -

- Material -
- Turcon[®] or Zurcon[®] -





■ Turcon® Variseal® M2

Description

The Turcon® Variseal® M2 is a single-acting seal consisting of a U-shaped seal jacket and a V-shaped corrosion-resistant spring.

The Variseal® M2 has an asymmetric seal profile. The heavy profile of its dynamic lip with an optimized front angle offers good leakage control, reduced friction and long service life.

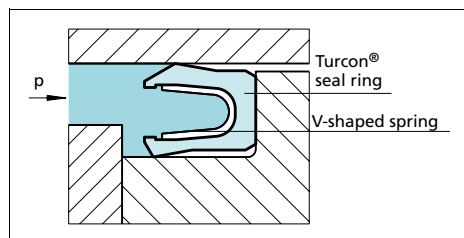

Figure 46 Turcon® Variseal® M2

At low and zero pressure, the metal spring provides the primary sealing force. As the system pressure increases, the main sealing force is achieved by the system pressure and ensures a tight seal from zero to high pressure.

The possibility of matching suitable materials for the seal and the spring allows use in a wide range of applications going beyond the field of hydraulics, e.g. in the chemical, pharmaceutical and foodstuffs industries.

The Variseal® M2 can be sterilized and is available in a special Hi-Clean version where the spring cavity is filled with a silicone gel preventing contaminants from being entrapped in the seal. This design also works well in applications involving mud, slurries or adhesives to keep grit from packing into the seal cavity and inhibiting the spring action.

For applications with highly viscous media, please contact your local sales office.

Variseal® M2 seals can be installed in grooves to AS4716 and ISO 3771. The seals can only be installed to a limited extent in closed grooves. For installation instructions, see Table VII.

Advantages

- Resistant to most fluids and chemicals
- Low coefficients of friction
- Stick-slip-free operating for precise control
- High abrasion resistance and dimensional stability
- Can handle rapid changes in temperature
- No contamination in contact with foodstuffs, pharmaceutical and medicinal fluids
- Sterilizable
- Unlimited shelf life

Application Examples

The Turcon® Variseal® M2 is the recommended sealing element for all applications requiring stick-slip-free operation as well as chemical resistance against almost all media. Some applications include:

- Valves
- Pumps
- Separators
- Actuators
- Dosing devices

It requires a mating surface of high quality to avoid high wear rates.



Turcon® Variseal® M2

Technical Data

Operating conditions

Pressure: For static loads: 5,800 psi (40MPa)
For dynamic loads: 2,900 psi (20 MPa)

Speed: Reciprocating up to 50 ft/s (15 m/s)
Rotating up to 3.3 ft/s (1 m/s)

Temperature: -94°F to +500°F (-70°C to +260°C)

For specific applications at lower temperatures, please contact your local Trelleborg Sealing Solutions sales office.

Media: Virtually all fluids, chemicals and gases

Important Note:

The above data are maximum values and cannot be used at the same time. e.g. the maximum operating speed depends on material type, pressure, temperature and gap value. Temperature range also dependent on medium.

Materials

All materials used are physiologically safe. They have no odor or taste-affecting substances.

The following material combination has proved effective for most fluid applications:

Seal ring: Turcon® T 40

Spring: Stainless steel, Material No. AISI 301
Material code S

For gas applications use:

Seal ring: T05 or Z80

For use in accordance with the demands of the Food and Drug Administration, suitable materials are available on request.

Table XLII Turcon® and Zurcon® Materials for Variseal® M2

Material, Applications, Properties	Code	Spring Material	Code	Operating Temp.* °F	Mating Surface Material	PSI Max.
Turcon® T40 For all lubricating and non-lubricating hydraulic fluids, hydraulic oils without zinc, water hydraulic, hard mating surfaces. Surface texture not suitable for gases. Carbon fiber-filled Color: gray	T40	AISI 301	S	-94 to +500	Steel Cast iron Stainless steel Aluminium Bronze Alloys	5,800
Turcon® T05 For all lubricating hydraulic fluids, soft mating surfaces, very good sliding properties, low friction. Color: turquoise	T05	AISI 301	S	-94 to +500	Steel, hardened	2,900
Zurcon® Z80 For lubricating and non-lubricating hydraulic fluids, high abrasion resistance, very good chemical resistance, limited temperature resistance. FDA compliance. Ultra high molecular weight polyethylene Color: white to off-white	Z80	AISI 301	S	-94 to +176	Steel Stainless steel Aluminium Bronze Ceramic coating	5,800
Zurcon® Z48 For tight sealing with long wear life, in applications without high temperatures or corrosive chemicals Colour: black	Z48	AISI 301	S	-76 to +266	Steel Steel, chrome plated Cast iron Stainless steel Aluminium Bronze Alloys Ceramic coating	5,800

* Depending on media. Highlighted materials are standard.



■ Installation Recommendation (Inch Piston Series)

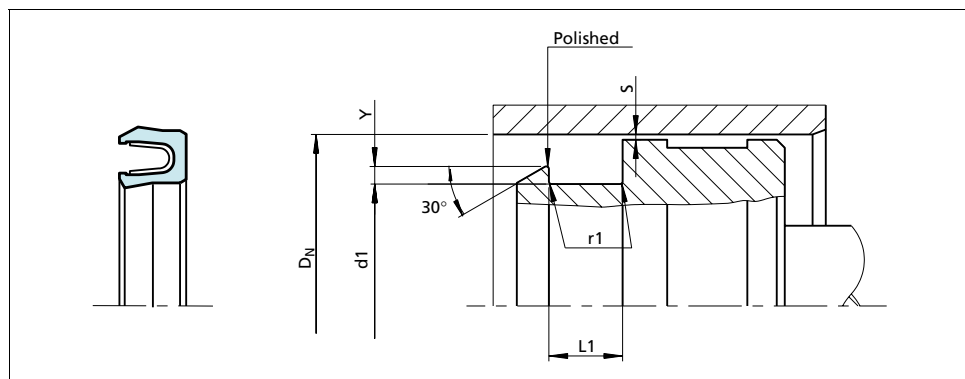

Figure 47 Installation drawing

Table XLIII Installation recommendation

TSS Series Number for Types	Cross-section	Groove Width	Radius	Radial Clearance S max.*			
				300 psi	1500 psi	3000 psi	5000 psi
Variseal M2	$D_N - d_1$ (Ref.)	$L_1 + .010$	r_1				
PVAA	.062	.094	.010	.008	.004	.003	.002
PVAB	.093	.141	.015	.010	.006	.004	.003
PVAC	.125	.187	.015	.014	.008	.006	.003
PVAD	.187	.281	.015	.020	.010	.008	.004
PVAE	.250	.375	.020	.024	.012	.010	.005
PVAF	.375	.591	.020	.030	.015	.012	.006

* At pressures > 40 MPa (5,800 psi) use diameter tolerance H8/f8 (bore/piston) in area of the seal.

Ordering example

Turcon® Variseal® M2, standard range, Series PVA3 (from Table XXXVI)

Bore diameter: $D_N = 80.0$ mm

TSS Part No.: PVACNB230 (from Table XLIII)

Select the material from Table XLII. The corresponding code numbers are appended to the TSS Part No. (from Table XLIII). Together they form the TSS Article No.

For all intermediate sizes not shown in Table XLIII, the TSS Article No. can be determined from the example opposite.

TSS Article No. PVAC NB230 - T40 S M

TSS Series No. _____

Size / dash No. _____

Quality Index (Standard) _____

Material code (Seal ring) _____

Material code (Spring) _____

Load (Spring) _____



Table XLIV Installation dimensions / TSS Part No.

Bore Diameter	Groove Diameter	Groove Width	TSS Part No.
D _N H9	d ₁ h9	L ₁ +.010	
.250	.125	.094	PVAANB006
.313	.188	.094	PVAANB008
.375	.187	.141	PVABNB106
.438	.250	.141	PVABNB108
.500	.312	.141	PVABNB109
.563	.375	.141	PVABNB110
.625	.437	.141	PVABNB111
.688	.500	.141	PVABNB112
.750	.500	.188	PVACNB206
.813	.563	.188	PVACNB207
.875	.625	.188	PVACNB208
.938	.688	.188	PVACNB209
1.000	.750	.188	PVACNB210
1.063	.813	.188	PVACNB211
1.125	.875	.188	PVACNB212
1.188	.938	.188	PVACNB213
1.250	1.000	.188	PVACNB214
1.313	1.063	.188	PVACNB215
1.375	1.125	.188	PVACNB216
1.438	1.188	.188	PVACNB217
1.500	1.125	.281	PVADNB320
1.625	1.250	.281	PVADNB322
1.750	1.375	.281	PVADNB324
1.875	1.500	.281	PVADNB325
2.000	1.625	.281	PVADNB326
2.125	1.750	.281	PVADNB327
2.250	1.875	.281	PVADNB328
2.375	2.000	.281	PVADNB329
2.500	2.125	.281	PVADNB330
2.625	2.250	.281	PVADNB331
2.750	2.375	.281	PVADNB332
2.875	2.500	.281	PVADNB333
3.000	2.625	.281	PVADNB334
3.125	2.750	.281	PVADNB335
3.250	2.875	.281	PVADNB336
3.375	3.000	.281	PVADNB337

Bore Diameter	Groove Diameter	Groove Width	TSS Part No.
D _N H9	d ₁ h9	L ₁ +.010	
3.500	3.125	.281	PVADNB338
3.625	3.250	.281	PVADNB339
3.750	3.375	.281	PVADNB340
3.875	3.500	.281	PVADNB341
4.000	3.625	.281	PVADNB342
4.125	3.750	.281	PVADNB343
4.250	3.875	.281	PVADNB344
4.375	4.000	.281	PVADNB345
4.500	4.125	.281	PVADNB346
4.625	4.125	.375	PVAENB422
4.750	4.250	.375	PVAENB423
4.875	4.375	.375	PVAENB424
5.000	4.500	.375	PVAENB425
5.125	4.625	.375	PVAENB426
5.250	4.750	.375	PVAENB427
5.375	4.875	.375	PVAENB428
5.500	5.000	.375	PVAENB429
5.625	5.125	.375	PVAENB430
5.750	5.250	.375	PVAENB431
6.000	5.500	.375	PVAENB433
6.250	5.750	.375	PVAENB435
6.500	6.000	.375	PVAENB437
6.750	6.250	.375	PVAENB438
7.000	6.500	.375	PVAENB439
7.250	6.750	.375	PVAENB440
7.500	7.000	.375	PVAENB441
7.750	7.250	.375	PVAENB442
8.000	7.500	.375	PVAENB443
8.500	8.000	.375	PVAENB445
9.000	8.500	.375	PVAENB446
9.500	9.000	.375	PVAENB447
10.000	9.500	.375	PVAENB448
10.500	10.000	.375	PVAENB449
11.000	10.500	.375	PVAENB450
11.500	11.000	.375	PVAENB451
12.000	11.500	.375	PVAENB452





Bore Diameter	Groove Diameter	Groove Width	TSS Part No.
D_N H9	d₁ h9	L₁ +.010	
12.500	12.000	.375	PVAENB453
13.000	12.500	.375	PVAENB454
13.500	13.000	.375	PVAENB455
14.000	13.500	.375	PVAENB456
14.500	14.000	.375	PVAENB457
15.000	14.500	.375	PVAENB458
15.500	15.000	.375	PVAENB459

The sizes listed in **bold** font are preferred sizes (more likely to be available for immediate shipment). Other dimensions and all intermediate sizes up to 102 inches (2600mm) diameter can be supplied.



Turcon® Variseal® M2

COMPACT SEAL PHD/P

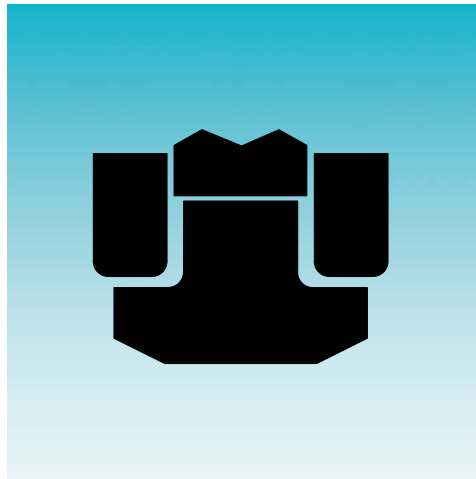

- Double-Acting -
- Elastomer-Energized Zurcon[®] Slipper Seal -

- Material -
- Zurcon[®] Polyurethane, POM -





■ Compact Seal PHD/P

Description

The PHD/P Seal is a high-pressure heavy-duty piston seal with excellent leakage control and superior extrusion and wear resistance.

The PHD/P seal is a combination of a Zurcon® polyurethane slipper seal energized by an elastomer profile ring and completed with two back-up rings (POM). It is manufactured with a predefined interference fit, which together with the squeeze of the elastomer part ensures a good sealing effect even at low system pressure. At higher pressures the elastomer part is energized by the system pressure and activates the slipper seal in the radial direction.

The back-up rings prevent the slipper seal from extrusion and ensure a long service life even under harsh conditions.

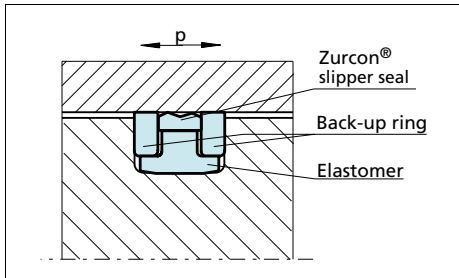

Figure 49 PHD/P Seal

Advantages

- Simple groove design
- Excellent sealing effect
- Excellent wear resistance
- Increased clearance possible
- Long service life

Application Examples

The PHD/P Seal is the recommended sealing element for double-acting pistons of hydraulic cylinders working in very harsh conditions. Some applications include:

- Excavators
- Heavy duty cylinders

Technical Data

Operating conditions

Pressure: Up to 5,800 psi (40 MPa)
Peak pressure up to 8,700 psi (60 MPa)

Velocity: Up to 1.65 ft/s (0.5 m/s)

Temperature: -31°F to +230°F (-35°C to +110°C)

Media: Mineral oil based hydraulic fluids

Clearance: The maximum permissible radial clearance S_{max} is shown in Table XXXIX, as a function of the operating pressure and functional diameter

Important Note:

The above data are maximum values and cannot be used at the same time. e.g. the maximum operating speed depends on material type, pressure, temperature and gap value. Temperature range also dependent on medium.

Materials

Standard Application:

For hydraulic components in mineral oils or medium with good lubricating performance

Seal ring: Zurcon® Z20 93 Shore A

Energizer: NBR 80 Shore A

Back-up rings: POM

Material code for the set: Z2053

Please contact your local Trelleborg Sealing Solutions sales office for inch dimensions. For metric dimensions, please use the metric catalog.



Compact Seal PHD/P

POLYPAC[®] - VEEPAC CH/G1

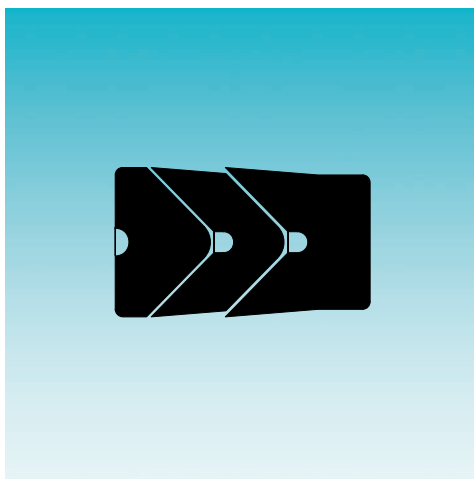

- **Single-Acting** -
- **Chevron Vee Packing Set** -
- **With Support and Pressure-Energizing Ring** -
- **Material** -
- **POM, PTFE, Fabric-Reinforced Rubber** -





■ Veepac CH/G1

Description

Veepac G1 is a set of fabric-reinforced rings comprised of one support ring, one sealing ring and a pressure-energizing ring. It is a single-acting piston seal.

The support ring, or base ring, is manufactured out of nitrile elastomer with high Shore A hardness and reinforced with impregnated cotton fabric layers for an optimal extrusion resistance.

The intermediate ring - the sealing ring - is a fabric-reinforced nitrile elastomer with good resilience characteristics enabling radial deflection under pressure load. The optimum sealing force is applied to the bore to be sealed.

The energizer, or spreader ring, is made of POM or PTFE. Its function is to ensure a uniform pre-load of the seal.

In some specific applications the energizer ring is made out of Acetal resin or Phenolic resin. Please contact your local Trelleborg Sealing Solutions sales office for further details.

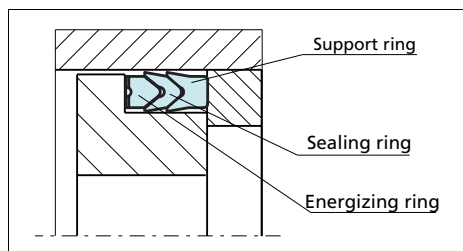

Figure 51 Veepac CH/G1

Advantages

- Exceptional wear resistance
- Pre-load adjustment capability
- Excellent behavior in harsh conditions

Application Examples

The Veepac seal is recommended for single-acting or double-acting (back-to-back installation) pistons in the following applications:

- Mining equipment
- Excavator cylinders
- Steel mill cylinders
- Presses

Technical Data

Operating conditions:

Pressure: Up to 5,800 psi (40 MPa)

Velocity: Up to 1.65 ft/s (0.5 m/s)

Temperature: -22°F to +392°F (-30°C to +200°C), depending on material

Media: Mineral oil, water glycol, water emulsions

Important Note:

The above data are maximum values and cannot be used at the same time. e.g. the maximum operating speed depends on material type, pressure, temperature and gap value. Temperature range also dependent on medium.

Materials

The following material can be delivered:

Material Set Code	Temperature °F	Sealing Ring Material	Energizer/ Spreader Ring Material
N00OC	-22 to +266	Cotton-reinforced NBR	POM
V0P0C	-4 to +302	Cotton-reinforced FKM	PTFE
V0P0A	-4 to +392	Aramid fiber-reinforced FKM	PTFE

Highlighted material is standard.

Please contact your local Trelleborg Sealing Solutions sales office for inch dimensions. For metric dimensions, please use the metric catalog.



COMPACT SEAL D A S TYPE A/B

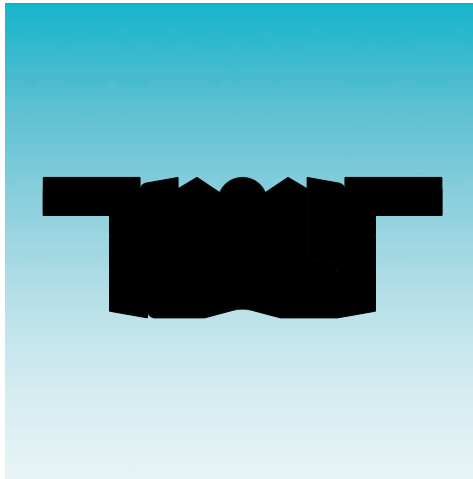

- Double-Acting -
- Combined Seal and Wear Ring -
- Material -
- NBR, Polyester Elastomer + POM -





■ Compact Piston Seals

Description

The Compact Seal is a double-acting seal and guide element comprised of an elastomeric profile seal ring, two back-up rings and two guide rings. The profile seal ring seals in both the static and dynamic range while the back-up rings prevent extrusion into the sealing gap. The function of the guide rings is to guide the piston in the cylinder tube and to absorb transverse forces. The design provides a compact seal and guide combination for a closed or split installation groove.

Designs

The Compact Seal is available in various profile geometries. The choice is normally determined by the existing installation grooves.

DAS Type A

This type is characterized by the straight, long-sided L-profiles of the guide rings. Compared with Type B, it exhibits a smaller groove depth with the same cylinder diameter.

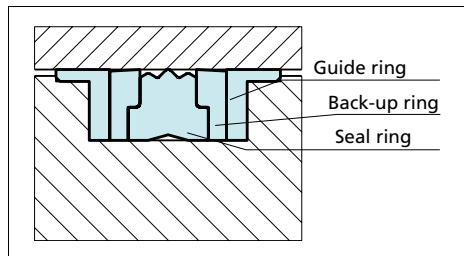

Figure 53 D-A-S Compact Seal, Type A

Please contact your local Trelleborg Sealing Solutions sales office for inch dimensions. For metric dimensions, please use the metric catalog.

DAS Type B

This type is characterized by a Z-shaped back-up ring which forms a chamber with the elastomer seal ring on the inside and is centered on the outside by the guide ring.

For many piston diameters, the width of the guide ring (dimension L2) can be selected due to sideloads.

Due to the larger groove depth, the profile of the seal ring is more rigid than that of Type A and requires higher installation forces.

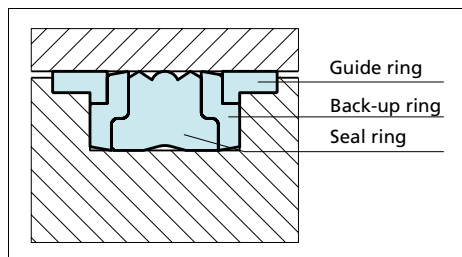

Figure 54 D-A-S Compact Seal, Type B

Advantages

- Good sealing effect, also suitable for holding cylinders
- Capable of installation in closed grooves for reduced machining costs
- Economic sealing and guiding solution
- Simple snap installation



Compact Seal

Application Examples

Compact seals are the recommended sealing element for double-acting pistons of hydraulic components such as:

- Machine tools
- Truck cranes
- Forklifts & handling machinery
- Agriculture equipment

Technical Data

Operating conditions

Pressure:	Up to 5,000 psi (35 MPa) peak up to 5,800 psi (40 MPa)
Velocity:	Up to 1.65 ft/s (0.5 m/s)
Temperature:	-22°F to +212°F (-30°C to +100°C)
Media:	Mineral oil-based hydraulic fluids, flame retardant hydraulic fluids, HFA, HFB, HFC (< +104°F (+40°C))

Important Note:

The above data are maximum values and cannot be used at the same time. e.g. the maximum operating speed depends on material type, pressure, temperature and gap value. Temperature range also dependent on medium.

Materials

- The D-A-S Compact Seal is available in the following material combinations:

Profile seal:	NBR 70 Shore A
Back-up ring:	Polyester elastomer
Guide rings:	POM
Set ref.:	NCRO

- The DBM Compact Seal is available in the following material combinations:

Profile seal:	NBR 80 Shore A
Back-up ring:	Polyester elastomer
Guide rings:	POM
Set reference:	N8RO

POLYPAC[®] - SELEMASTER DSM

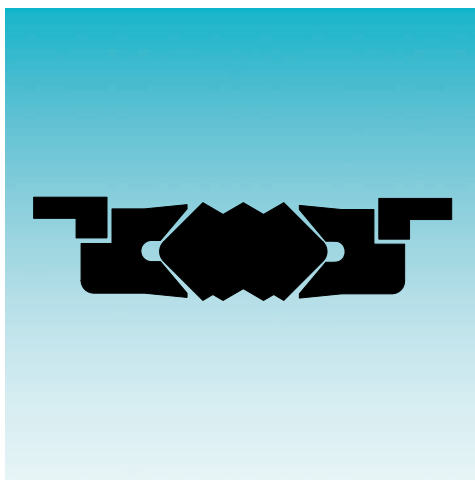

- Double-Acting -
- Combined Seal and Wear Ring -
- Material -
- NBR + Fiber-Reinforced NBR + POM -





Description

The piston seal DSM range has been designed to meet the needs of hydraulic equipment operating at high pressures and subjected to severe loading and vibration conditions.

The main sealing element is manufactured in a highly compression set resistant nitrile. The most important qualities of this element is the design of the multiple sealing lips for maximum sealing efficiency and end face configuration, which ensures that the selemaster can tolerate vibrations and severe misalignment.

The two support rings are made in cotton fabric-reinforced nitrile elastomer; the "U" shape is energized when pressure is applied.

The last elements are the two guide rings manufactured in acetal resin which have the function of anti-extrusion rings.

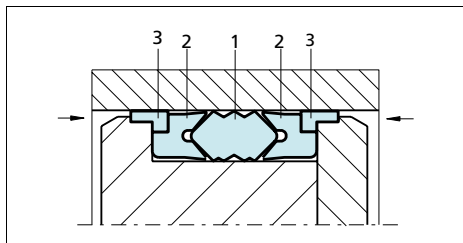

Figure 56 Selemaster design

- 1) Sealing element
- 2) Support ring
- 3) Guide ring

Advantages

- Effective sealing during vibration and shock loading
- High sealing efficiency
- Extrusion resistance at high pressure

Application Examples

- Earth moving machines
- Excavators
- Lift platforms

Technical Data

Operating conditions

Pressure: Up to 10,150 psi (70 MPa)

Velocity: Up to 1.65 ft/s (0.5 m/s)

Temperature: -40°F to +266°F (-40°C to +130°C)

Media: Hydraulic fluids

Mineral oil-based hydraulic fluids,
water and water/glycol emulsions

Groove type: Open

Important Note:

The above data are maximum values and cannot be used at the same time. e.g. the maximum operating speed depends on material type, pressure, temperature and gap value. Temperature range also dependent on medium.

Standard Material

- | | |
|--------------------|-----------------------|
| 1) Sealing element | NBR 80 |
| 2) Support ring | Cotton-reinforced NBR |
| 3) Guide ring | POM |

Please contact your local Trelleborg Sealing Solutions sales office for inch dimensions. For metric dimensions, please use the metric catalog.



POLYPAC® - Selemaster DSM

SCRAPERS

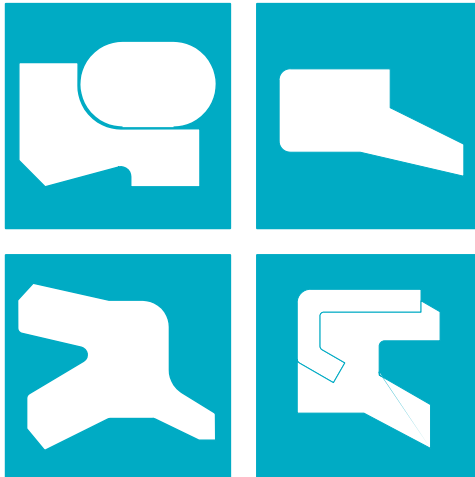



Scrapers

Contents

Choice of the Scraper Element	4
Zurcon® Scraper DA 22	7
Zurcon® Scraper DA 24	13
Zurcon® Scraper WKE	19
Scraper DA 17	25
Turcon® Excluder® 2	29
Turcon® Excluder® 5	37
Zurcon® Scraper WAE	45
Scraper WRM	51
Zurcon® Scraper SWP	55
Scraper WSA	61
Metal Scraper	67

■ Choice of the Scraper Element

Scrapers are installed in hydraulic cylinders to wipe any dirt, foreign particles, chips, moisture, etc. from the rod as it is retracted into the system. This prevents contamination of the hydraulic fluid, which would damage wear rings, seals and other components.

Single and double-acting scrapers are available, depending on the application and the sealing system. Single-acting scrapers are designed to keep out contamination from the outside; double-acting scrapers have the additional function of regulating the fluid film to avoid any external leakage.

In order to satisfy both the different technical and economic demands, there is a complete range of scrapers with optimized geometries made with high-quality materials.

Before selecting the scraper and the material, it is essential to know all the desired functional parameters. The table on the following pages allows a preliminary choice of the scraper type and material, according to the specific requirements of the application.

Further application information together with specific design and installation instructions for the particular scraper type and material can be found in this catalog.

Notes on Ordering

All multi-element standard scrapers are supplied as a complete set. The supply includes the scraper and energizing element.







Designs of scrapers no longer contained in this catalog continue to be available. For new applications we recommend the use of the DIN/ISO series listed in this catalog.

The sizes contained in this catalog are generally available from stock and can be supplied on short notice. We reserve the right to modify our article structure without prior notice.

Please do not hesitate to contact your local Trelleborg Sealing Solutions sales office for further information on specific applications and special technical questions.

Scrapers





Table I Selection Criteria for Scrapers

Scraper		Application	Standard	Size Range	Groove Type	Action		Technical Data*		Recommended Scraper Material		
Type	Page					Field of Application			ISO/DIN		Inch	Inch
			Light	Medium	Heavy	Single	Double	°F		Ft/s		
 Zurcon® Scraper DA 22	7	ISO Standard cylinder	●	●	●	6195 Type C	.188 - 10	Split <.709 Closed >.709	X	-30/+212	3	Zurcon® Z201
		Industrial hydraulic cylinders	●	●	●							
 Zurcon® Scraper DA 24	13	Mobile hydraulics	●	●	●	-	2 - 10	Closed	X	-30/+212	1.6	Zurcon® Z201
		Construction machinery	●	●	●							
		Agriculture machinery	●	●	●							
 Zurcon® Scraper WKE	19	Agriculture machinery		●	●	-	.500 - 8	Open	X	-30/+212	3	Zurcon® Z201 + Metal
		Mobile hydraulic machinery		●	●							
 Scraper DA 17	25	Industrial hydraulics	●	●		-	.375 - 20	Split <.709 Closed >.709	X	-22/+230	3	NBR
		Machine Tools	●	●								
		Presses	●	●								
 Turcon® Excluder® 2	30	Industrial hydraulics	●	●	●		.25 - 102	Split <1.181 Closed >1.181	X	-49/+392	50	Turcon® T46
		Machine Tools	●	●	●							
		Injection molding machines	●	●	●							
		Servo hydraulic cylinders	●	●	●							
		Robotics	●	●	●							
 Turcon® Excluder® 5	37	Heavy duty mobile and Industrial hydraulics	●	●	●	6195 Type D	.750 - 102	Split <1.181 Closed >1.181	X	-49/+392	50	Turcon® T46
		Presses	●	●	●		.750 - 86			-49/+212	6	Zurcon® Z52
		Steel Mills	●	●	●							
 Zurcon® Scraper WAE	45	Agriculture machinery	●	●		-	.315 - 8	Split <.515 Closed >.515	X	-30/+230	3	Zurcon® Z201
		Mobile hydraulic machinery	●	●								

* The data above are maximum values and cannot be used at the same time

** Temperature range depends on choice of elastomer material and media.

Scrapers

Scraper		Application			Standard	Size Range	Groove Type	Action		Technical Data*		Recommended Scraper Material
Type	Page	Field of Application			ISO/DIN	Inch	Inch	Single	Double	Temp. Range**	Velocity	
			Light	Medium						Heavy	°F	
 Scraper WRM	51	Agriculture machinery	●	●	-	.500 - 20	Closed	X		-22/+230	3	NBR
		Handling equipment	●	●								
 Zurcon® Scraper SWP	55	Construction machinery		●	-	2 - 8	Open	X		-30/+212	3	Zurcon® Z201 + Metal
		Link pin seals		●								
 Zurcon® Scraper WRM/C-WSA	61	Agriculture machinery	●	●	-	.500 - 8	Open	X		-22/+230	3	NBR + Metal
		Mobile hydraulic machinery	●	●								
 Metal Wiper	67	Agriculture machinery	●	●	-	.500 - 8,5	Open	X		-40/+230	3	Metal + NBR + Brass
		Mobile hydraulic machinery	●	●								
		ISO Standard cylinder	●	●								

* The data above are maximum values and cannot be used at the same time

** Temperature range depends on choice of elastomer material and media.

ZURCON[®] SCRAPER DA 22

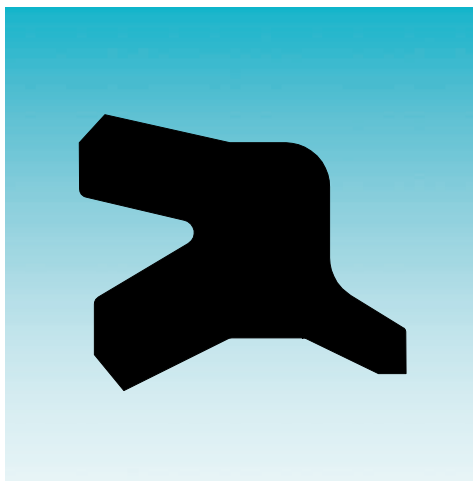

- Double-Acting -

- Material -

- Zurcon[®] Polyurethane -





■ Zurcon® Scraper DA 22

Description

The DA 22 is a double-acting polyurethane scraper for closed groove installation. Significant improvements are achieved in profile geometry and material used if compared with conventional elastomeric scrapers.

The scraper lip is designed so that it effectively removes dirt while leaving only the oil film which is required for correct operation. The radial squeeze is sufficient to remove particles, dust and water.

The scraping lip, which faces inward, it assumes a sealing function even under low pressure. The static seal is achieved by a tight radial fit between the scraper body and the groove.

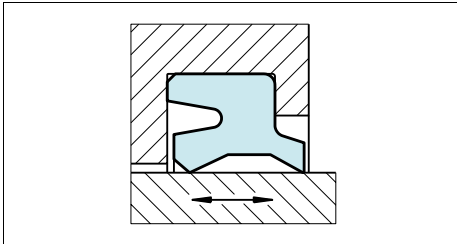

Figure 1 Scraper DA 22

Advantages

- Good scraping effect
- Wear resistant, long service life
- Retaining residual oil film
- Standard elements for standardized installation grooves

Application Examples

Due to the outstanding wiping capacities, the DA22 scraper is recommended wherever there are dusty and humid conditions, especially for the following applications:

- ISO standard cylinders
- Hydraulic industrial cylinders
- Agriculture machinery

Technical Data

Operating conditions

Pressure

Scraper side: Atmospheric pressure

Seal side:

Pressures up to 290 psi (2 MPa)
A relief bore must be provided with higher pressures.

Velocity:

Up to 3 ft/s (1 m/s)

Temperature:

-31°F to +212°F (-35°C to +100°C)

Media:

Mineral oils and greases

Groove type:

Closed

Important Note:

The above data are maximum values and cannot be used at the same time. e.g. the maximum operating speed depends on material type, pressure, temperature and gap value. Temperature range also dependent on medium.

Materials

Standard application:

Zurcon® Polyurethane: 93 Shore A

Material code:

Z201

Color:

Turquoise



Installation Recommendation (Inch Series)

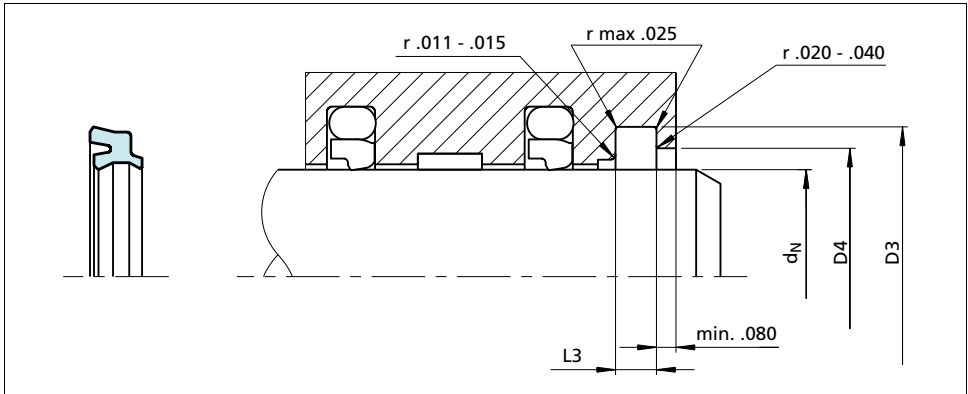

Figure 2 Installation drawing

Table II Installation Recommendation

TSS Series No.	Rod Diameter d_N f8/h9	Groove Diameter	Relief Diameter	Groove Width	Radius
	Standard Application	D_3 H9	D_4 H11	L_3 +.008	r_1
WDE1	.250 - .812	d_N +.302	d_N +.120	.203	.025
WDE2	.813 - 2.499	d_N +.365	d_N +.135	.218	.025
WDE3	2.500 - 9.999	d_N +.495	d_N +.195	.281	.025

Ordering Example

Rod diameter: $d_N = 2.000$ inches
 TSS Part No.: WDE202000
 Material Code (Scraper): Z201

TSS Article No.	WDE2	02000	-	Z201
TSS Series No.				
Rod diameter x 1000				
Quality Index				
Material Code (Scraper)				



Table III Installation Dimensions / TSS Part No.

Rod Diameter	Groove Diameter	Groove Width	Bore Diameter	TSS Part No.
d_n h9	D_3 H9	L_3 +0.10	D_4 h11	
.500	.802	.203	.620	WDE100500
.625	.927	.203	.745	WDE100625
.750	1.052	.203	.870	WDE100750
.875	1.240	.218	1.010	WDE200875
1.000	1.365	.218	1.135	WDE201000
1.125	1.490	.218	1.260	WDE201125
1.250	1.615	.218	1.385	WDE201250
1.375	1.740	.218	1.510	WDE201375
1.500	1.865	.218	1.635	WDE201500
1.625	1.990	.218	1.760	WDE201625
1.750	2.115	.218	1.885	WDE201750
1.875	2.240	.218	2.010	WDE201875
2.000	2.365	.218	2.135	WDE202000
2.125	2.490	.218	2.260	WDE202125
2.250	2.745	.281	2.445	WDE302250
2.375	2.870	.281	2.570	WDE302375
2.500	2.995	.281	2.695	WDE302500
2.750	3.245	.281	2.945	WDE302750
3.000	3.495	.281	3.195	WDE303000
3.250	3.745	.281	3.445	WDE303250
3.500	3.995	.281	3.695	WDE303500
3.750	4.245	.281	3.945	WDE303750
4.000	4.495	.281	4.195	WDE304000
4.250	4.745	.281	4.445	WDE304250
4.500	4.995	.281	4.695	WDE304500
4.750	5.245	.281	4.945	WDE304750
5.000	5.495	.281	5.195	WDE305000
5.250	5.745	.281	5.445	WDE305250
5.500	5.995	.281	5.695	WDE305500
5.750	6.245	.281	5.945	WDE305750
6.000	6.495	.281	6.195	WDE306000
6.500	6.995	.281	6.695	WDE306500
7.000	7.495	.281	7.195	WDE307000

The sizes listed in **bold** font are preferred sizes (more likely to be available for immediate shipment).
Up to .7 inches (18 mm) diameter we recommend a split groove.
Other dimensions and all intermediate sizes up to 20 inches (508 mm) diameter can be supplied.



Zurcon® Scraper DA 22

Rod Diameter	Groove Diameter	Groove Width	Bore Diameter	TSS Part No.
d_n h9	D_3 H9	L_3 +.010	D_4 h11	
7.500	7.995	.281	7.695	WDE307500
8.000	8.495	.281	8.195	WDE308000
8.500	8.995	.281	8.695	WDE308500

The sizes listed in **bold** font are preferred sizes (more likely to be available for immediate shipment).

Up to .7 inches (18 mm) diameter we recommend a split groove.

Other dimensions and all intermediate sizes up to 20 inches (508 mm) diameter can be supplied.

ZURCON[®] SCRAPER DA 24

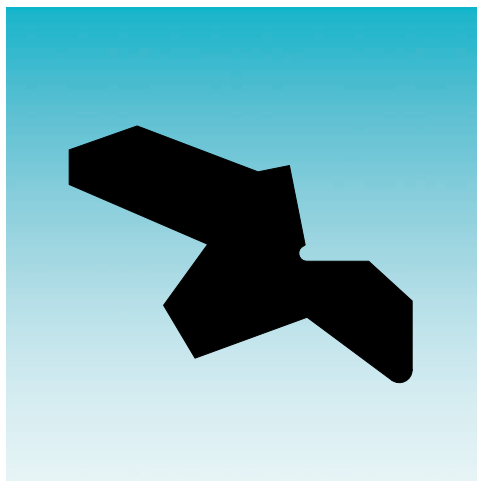

- Double-Acting -

- Material -

- Zurcon[®] Polyurethane -





■ Zurcon® Scraper DA 24

Description

The DA 24 is a double-acting scraper made of polyurethane. It is ideal for severe operating conditions and heavy attack of dirt.

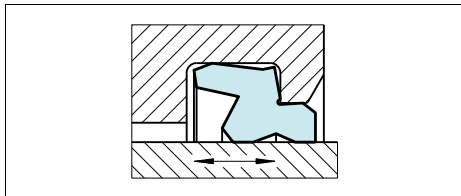

Figure 3 Scraper DA 24

The special design of the inward-facing sealing lip contributes to an optimum contact pressure resulting in a very high scraper effect of the residual oil film.

The outward-facing scraper lip leans against the housing. This ensures an optimum sealing force and prevents the penetration of dirt and water across the groove bottom. Also at heavy attacks of dirt and side steering of the piston rod the scraper effect remains stable. The polyurethane material ensures a high service life, also under heavy requirements, and ensures against installation damage.

Advantages

- Very good scraper effect of the outward lip
- Very good sealing effect of the inward lip
- Reliable at side steering of the piston rod
- Sturdy and wear-resistant
- Simple installation

Application examples

The scraper DA 24 is especially suitable for applications in:

- Construction machinery
- Agriculture and forestry machinery
- Mobile hydraulics
- High attack of dirt
- Side steering of piston rod

Scraper DA 24 is used in connection with our rod seal system Zurcon® RU-9 and Zurcon® Buffer seal.

Technical Data

Operating conditions:

Pressure: Max. 725 psi (5 MPa)

Velocity: Up to 1.6 ft/s (0.5 m/s)
For applications at high strokes and higher speed, please contact your local Trelleborg Sealing Solutions sales office

Temperature: -31°F to +212°F (-35°C to +100°C)

Media: Mineral oil-based hydraulic fluids

Important Note:

The above data are maximum values and cannot be used at the same time. e.g. the maximum operating speed depends on material type, pressure, temperature and gap value. Temperature range also dependent on medium.

Material

The scraper DA 24 consists of Zurcon® polyurethane material with high wearability, low deformation and high resistance to extrusion.

Standard:

Special Polyurethane: Zurcon® Z201 93 Shore A

Color: Turquoise



Installation Recommendation (Inch Series)

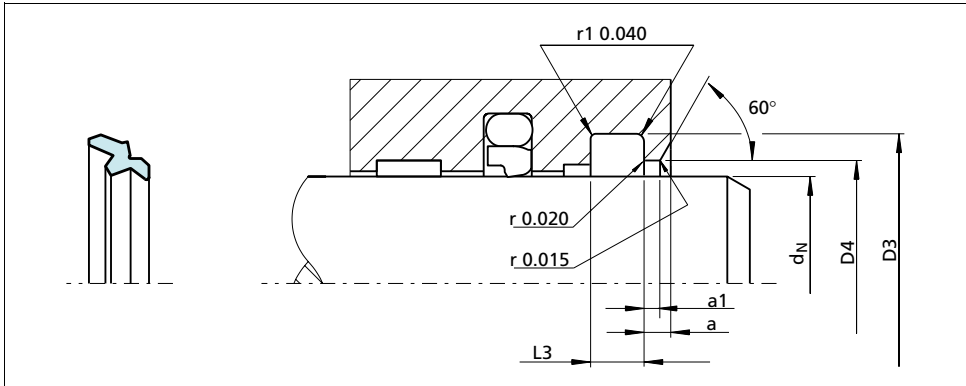

Figure 4 Installation drawing

Table IV Installation Recommendation

TSS Series No.	Rod Diameter	Groove Diameter	Relief Diameter	Groove Width	Step Width	Step Width
	d_N f8/h9	D_3 H9	D_4 H9	L_3 +.008	a min.	a_1 min
WDG1	2.000 - 2.749	d_N + .346	d_N + .173	.248	.125	.080
WDG2	2.750 - 5.499	d_N + .480	d_N + .236	.319	.160	.100
WDG3	5.500 - 10.000	d_N + .630	d_N + .315	.374	.200	.120

Ordering Example

Rod diameter: $d_N = 2.500$ inches
 TSS Part No.: WDG102500
 Material Code: Z201

TSS Article No.	WDG1	02500	-	Z201
TSS Series No.	_____			
Rod Diameter x 1000	_____			
Quality Index	_____			
Material Code	_____			

Notes:

1) Tolerances used are per ISO-286 ISO System Of Limits and Fits. The tolerances are converted from metric and rounded to the nearest three place decimal.



Table V Installation Dimensions / TSS Part No.

Rod Diam.	Groove Diam.	Groove Width	Relief Diam.	Step Width	Step Width	TSS Part No.
D_N f8/h9	D_3 H9	L_3 +.008	D_4 H9	a min	a1 min.	
2.000	2.346	0.248	2.173	0.125	0.080	WDG102000
2.250	2.596	0.248	2.423	0.125	0.080	WDG102250
2.500	2.846	0.248	2.673	0.125	0.080	WDG102500
2.750	3.230	0.319	2.986	0.160	0.100	WDG202750
3.000	3.480	0.319	3.236	0.160	0.100	WDG203000
3.250	3.730	0.319	3.486	0.160	0.100	WDG203250
3.500	3.980	0.319	3.736	0.160	0.100	WDG203500
3.750	4.230	0.319	3.986	0.160	0.100	WDG203750
4.000	4.480	0.319	4.236	0.160	0.100	WDG204000
4.500	4.980	0.319	4.736	0.160	0.100	WDG204500
5.000	5.480	0.319	5.236	0.160	0.100	WDG205000
5.500	6.130	0.374	5.815	0.200	0.120	WDG305500
6.000	6.630	0.374	6.315	0.200	0.120	WDG306000
6.500	7.130	0.374	6.815	0.200	0.120	WDG306500
7.000	7.630	0.374	7.315	0.200	0.120	WDG307000
8.000	8.630	0.374	8.315	0.200	0.120	WDG308000

The sizes listed in **bold** font are preferred sizes (more likely to be available for immediate shipment). Other dimensions and all intermediate sizes up to 10 inches (250 mm) diameter can be supplied.



ZURCON[®] SCRAPER WKE



- Single-Acting -
- Metal-Encased Wiper -

- Material -
- Zurcon[®] Polyurethane + Metal -





■ Zurcon® Scraper WKE

Description

The WKE is a polyurethane single-lipped wiper with integrated metal reinforcement for open groove assembly. These are typically used in heavy-duty and medium-duty tough applications that demand keeping the hydraulic system clean. The inner seal edge wipes the fluid film to maximize wiper life, yet prevent oil dripping in conjunction with the primary seal.

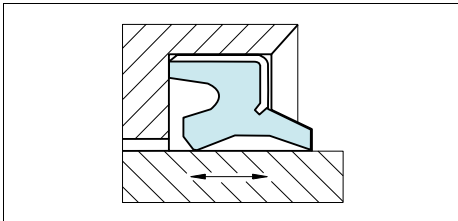

Figure 5 Scraper WKE

Advantages

- Space-saving construction
- High wear resistance / long life
- Simple, easy construction groove
- Firm fit in the groove due to metallic press fit
- Accurate fluid film control

Application Examples

Due to their outstanding wiping capacities WKE scrapers are recommended wherever there are dusty and humid conditions and especially for the following applications:

- Mobile hydraulic machinery
- Agriculture machinery
- Construction machinery
- Lift trucks

Technical Data

Velocity:	Up to 3 ft/s (1 m/s)
Temperature:	-31°F to +212°F (-35°C to +100°C)
Media:	Mineral oil-based hydraulic fluids
Groove type:	Open

Important Note:

The above data are maximum values and cannot be used at the same time. e.g. the maximum operating speed depends on material type, pressure, temperature and gap value. Temperature range also dependent on medium.

Materials

Standard application

Zurcon® Polyurethane:	93 Shore A
Color:	Turquoise
Metal case:	Non-alloyed steel DIN 1624
Material set code:	Z201



Installation Recommendation (Inch Series)

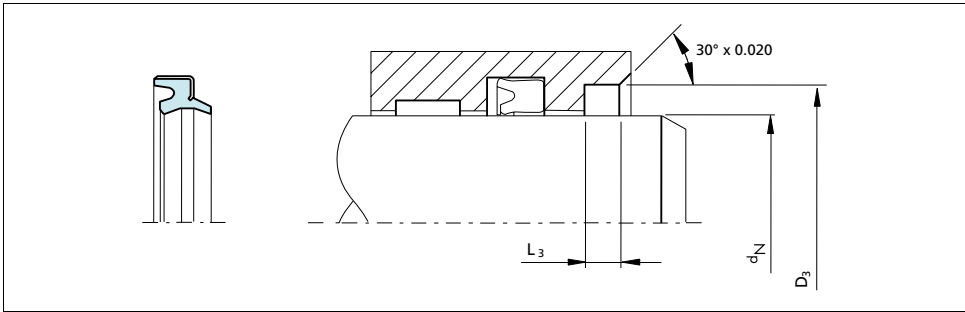

Figure 6 Installation drawing

Table VI Installation Recommendation

TSS Series	Rod Diameter d_N f8/h9		Groove Diameter D_3 H9	Groove Width L_3 +.015
	Standard Application	Light Application		
WKE2	.500 - .1.000	1.001 - 2.000	d_N +500	.250
WKE3	1.001 - 3.000	-	d_N +500	.313
WKE4	3.001 - 4.750	4.751 - 5.250	d_N +625	.313
WKE5	4.751 - 6.000	-	d_N +625	.375
WKE6	-	4.000 - 7.000	d_N +750	.375
WKE7	6.001 - 8.000	8.001 - 10.000	d_N +1.000	.500

Ordering Example

Rod diameter: d_N = 2.500 inches
 Groove diameter: D_3 = 3.000 inches
 TSS Part No.: WKE302500
 Material Set-Code: Z201

TSS Article No.	WKE3	02500	-	Z201
TSS Series No.				
Rod diameter x 1000				
Quality Index				
Material Code				

Notes:

1) Tolerances used are per ISO-286 ISO System Of Limits and Fits. The tolerances are converted from metric and rounded to the nearest three place decimal.



Table VII Installation Dimensions / TSS Part No.

Rod Diameter	Groove Diameter	Groove Width	TSS Part No.
d _N h9	D ₃ H11	L ₃ +.015	
1.000	1.500	.250	WKE201000
1.125	1.625	.313	WKE301125
1.250	1.750	.313	WKE301250
1.375	1.875	.313	WKE301375
1.500	2.000	.313	WKE301500
1.625	2.125	.313	WKE301625
1.750	2.250	.313	WKE301750
1.875	2.375	.313	WKE301875
2.000	2.500	.313	WKE302000
2.125	2.625	.313	WKE302125
2.250	2.750	.313	WKE302250
2.375	2.875	.313	WKE302375
2.500	3.000	.313	WKE302500
2.625	3.125	.313	WKE302625
2.750	3.250	.313	WKE302750
2.875	3.375	.313	WKE302875
3.000	3.500	.313	WKE303000
3.125	3.750	.313	WKE403125
3.250	3.875	.313	WKE403250
3.375	4.000	.313	WKE403375
3.500	4.125	.313	WKE403500
3.750	4.375	.313	WKE403750
4.000	4.625	.313	WKE404000
4.250	4.875	.313	WKE404250
4.500	5.125	.313	WKE404500
4.750	5.375	.313	WKE404750
5.000	5.625	.375	WKE505000
5.250	5.875	.375	WKE505250
5.500	6.125	.375	WKE505500
5.750	6.375	.375	WKE505750
6.000	6.625	.375	WKE506000
6.500	7.500	.500	WKE706500
7.000	8.000	.500	WKE707000
7.500	8.500	.500	WKE707500
8.000	9.000	.500	WKE708000

The sizes listed in **bold** font are preferred sizes (more likely to be available for immediate shipment). Other dimensions and all intermediate sizes up to 10 inches (250 mm) diameter can be supplied.



SCRAPER DA 17



- Double-Acting -

- Material -

- Elastomer -





■ Scraper DA 17

Description

The DA 17 is a molded double-acting elastomer scraper. It has two geometrically different scraper lips.

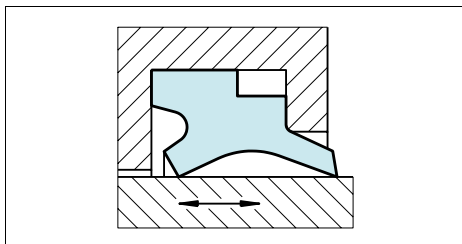

Figure 7 Scraper DA 17

The scraper is used for reciprocating piston rods and plunger pistons in hydraulic cylinders. It prevents the penetration of dirt into the system and holds back the residual oil film from the extending piston rod.

The scraper is preferably used in conjunction with our rod seals with a hydrodynamic back-pumping function.

Advantages

- Low friction
- Good scraping effect both inwards and outwards
- Simple, small installation groove
- Compact design
- Easy installation and removal without tools

Technical Data

Velocity:	Up to 3 ft/s (1 m/s)
Temperature:	-22°F to +230°F (-30° to +110°C)
Media:	Mineral oil-based hydraulic fluids, flame retardant hydraulic fluids (HFA, HFB, HFC), water, air, etc.

Important Note:

The above data are maximum values and cannot be used at the same time. e.g. the maximum operating speed depends on material type, pressure, temperature and gap value. Temperature range also dependent on medium.

Material

Standard material: NBR, 90 Shore A



Scraper DA 17

Installation Recommendation (Inch Series)

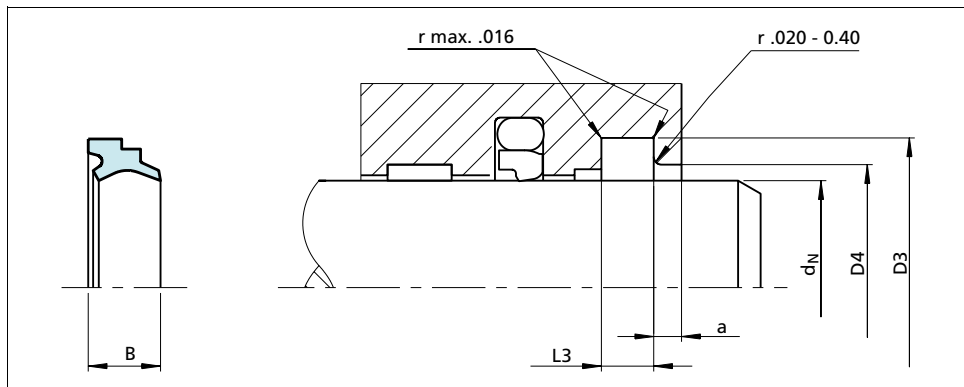

Figure 8 Installation drawing

Ordering Example

Scraper DA 17
 Rod diameter: $d_N = 2.500$ inches
 TSS Part No.: WD1700635 (from Table IX)
 Material: Standard material
 NBR 90 Shore A, Code N9

TSS Article No.	WD17	00635	-	N9
TSS Series No.				
Metric rod diameter x 10				
Quality Index				
Material Code				

Notes:

- 1) Tolerances used are per ISO-286 ISO System Of Limits and Fits. The tolerances are converted from metric and rounded to the nearest three place decimal.

Table IX Installation Dimensions / TSS Part No.

Rod Diam.	Groove Diam.	Groove Width	Relief Diam.	Step Width	TSS Part No.
d_N f8/h9	D_3 H9	L_3 +.015	D_4 h11	a 1 min.	
.500	.814	.236	.638	.079	WD1700127
.750	1.064	.236	.888	.079	WD1700191
1.000	1.314	.236	1.138	.079	WD1700254

The sizes listed in **bold** font are preferred sizes (more likely to be available for immediate shipment). Intermediate sizes above 5 inches (125 mm) diameter can also be supplied in impact vulcanized form. Other dimensions and all intermediate sizes up to 20 inches diameter can be supplied. Up to .7 inches (18 mm) diameter we recommend a split groove.



Rod Diam.	Groove Diam.	Groove Width	Relief Diam.	Step Width	TSS Part No.
d_N f8/h9	D_3 H9	L_3 +.015	D_4 h11	a1 min.	
1.250	1.564	.236	1.388	.079	WD1700318
1.500	1.841	.236	1.683	.079	WD1700381
1.750	2.064	.236	1.888	.079	WD1700445
2.000	2.314	.236	2.138	.079	WD1700508
2.250	2.564	.236	2.388	.079	WD1700572
2.500	2.814	.236	2.638	.079	WD1700635
2.750	3.064	.236	2.888	.079	WD1700699
3.000	3.314	.236	3.138	.079	WD1700762
3.250	3.564	.236	3.388	.079	WD1700826
3.500	3.814	.236	3.638	.079	WD1700889
3.750	4.064	.236	3.888	.079	WD1700953
4.000	4.472	.322	4.197	.118	WD1701016
4.250	4.972	.322	4.697	.118	WD1701143
5.000	5.472	.322	5.197	.118	WD1701270
5.500	5.972	.322	5.697	.118	WD1701397
6.000	6.472	.322	6.197	.118	WD1701524

The sizes listed in **bold** font are preferred sizes (more likely to be available for immediate shipment). Intermediate sizes above 5 inches (125 mm) diameter can also be supplied in impact vulcanized form. Other dimensions and all intermediate sizes up to 20 inches diameter can be supplied. Up to .7 inches (18 mm) diameter we recommend a split groove.

TURCON[®] EXCLUDER[®] 2



- Double-Acting -
- O-Ring-Energized Scraper -
- Material -
- Turcon[®] or Zurcon[®] + Elastomer -



■ Turcon® Excluder® 2

Description

The Turcon® Excluder® 2 is a double-acting scraper with two geometrically different scraper lips which are installed back-to-back. The Excluder® 2 is installed together with an elastic O-Ring in one groove. The scraper function is performed by the Excluder® 2. The O-Ring maintains the pressure of the scraper lips against the sliding surface and can compensate for any deflections of the piston rod.

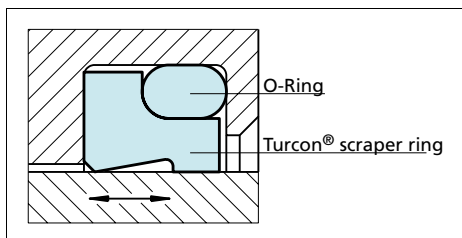

Figure 9 Turcon® Excluder® 2

The Excluder® 2 has two functions:

- Scrape contaminants from the retracting piston rod
- Hold back the residual oil film on the extending piston rod on the medium side

The Excluder® 2 is used with the Turcon® Stepseal®2K, i.e. seals with a hydrodynamic back-pumping function.

Advantages

- Outstanding sliding properties
- Stick-slip-free
- Can compensate for deflections of the piston rod or plunger
- Space-saving construction
- Very good scraping effect against outside contaminants, even with firmly adhered dirt, etc.
- Very good scraping effect from the inside against the residual oil film adhering to the surface of the piston rod
- Very high resistance to hydraulic media
- Available for all diameters up to 102.000 inches (2,600 mm) (Turcon®) and up to 86.000 inches (2,200 mm) (Zurcon®)

Technical Data

Velocity:	50 ft/s (15 m/s) for Turcon® materials
Temperature:	-49°F to +392°F (-45°C to +200°C) (depending on O-Ring material)
Media:	Mineral oil-based hydraulic fluids, flame retardant hydraulic fluids, environmentally safe hydraulic fluids (bio-oils), water, air and others, depending on the O-Ring material

Important Note:

The above data are maximum values and cannot be used at the same time. e.g. the maximum operating speed depends on material type, pressure, temperature and gap value. Temperature range also dependent on medium.

Materials

The following material combination has proven effective for most applications:

Excluder®:	Turcon® T46
O-Ring:	NBR, 70 Shore A

For other applications, other material combinations as listed in Table X, may also be used.

Design and Installation Instructions

Excluder® 2 scrapers can be installed in split and closed grooves (For installation dimensions, see table XI). Installation in closed grooves depends on the rod diameter, profile cross-section of the scraper and on the cord cross section of the corresponding O-Ring.



Turcon® Excluder® 2

Table X Turcon® and Zurcon® Materials for Excluder® 2

Material, Applications, Properties	Code	O-Ring Material	Code	O-Ring Operating Temp.* °F	Mating Surface Material	Speed Ft/s max.
Turcon® T46 Standard material for hydraulics, high compressive strength, good sliding and wear properties, BAM tested . Bronze-filled Color: grayish to dark brown	T46	NBR - 70 Shore A	N	-22 to +212	Steel, hardened Steel, chrome-plated Cast iron	50
		NBR - Low temp. 70 Shore A	T	-49 to +176		
		FKM - 70 Shore A	V	-14 to +392		
Turcon® T40 For all lubricating and non-lubricating hydraulic fluids, hydraulic oils without zinc, water hydraulic, soft mating surfaces . Surface texture not suitable for gases. Carbon fiber-filled Color: gray	T40	NBR - 70 Shore A	N	-22 to +212	Steel Steel, chrome-plated Cast iron Stainless steel Aluminium Bronze Alloys	50
		NBR - Low temp. 70 Shore A	T	-49 to +176		
		FKM - 70 Shore A	V	-14 to +392		
		EPDM-70 Shore A	E**	-49 to +293		
Turcon® T05 For all lubricating hydraulic fluids, hard mating surfaces, very good slide properties, low friction . Color: turquoise	T05	NBR - 70 Shore A	N	-22 to +212	Steel, hardened Steel, chrome-plated	50
		NBR - Low temp. 70 Shore A	T	-49 to +176		
		FKM - 70 Shore A	V	-14 to +392		
Zurcon® Z52 For lubricating hydraulic fluids, high abrasion resistance . Cast polyurethane Color: turquoise	Z52	NBR - 70 Shore A	N	-22 to +212	Steel Steel, hardened Steel, chrome-plated Cast iron Stainless steel Ceramic coating Aluminium Bronze Alloys	6.5
		NBR - Low temp. 70 Shore A	T	-49 to +176		

* The O-Ring operation temperature is only valid in mineral hydraulic oil. BAM: Tested by Bundes Anstalt Materialprüfung, Germany.

□ Highlighted materials are standard. ** Material not suitable for mineral oils.



Installation Recommendation (Inch Series)

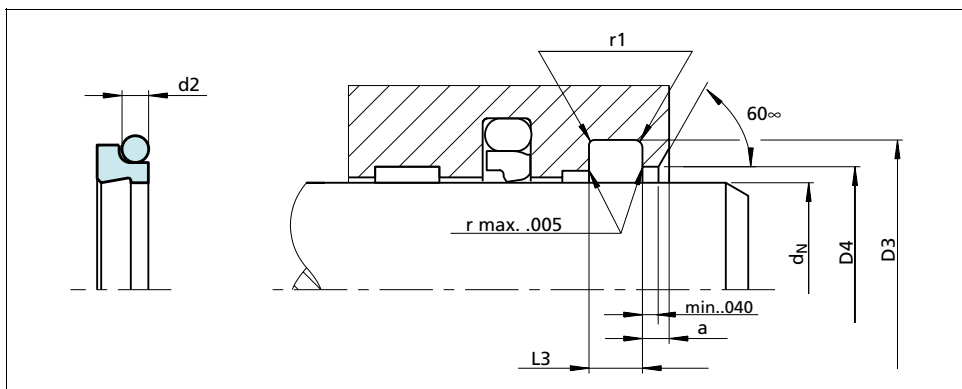

Figure 10 Installation drawing

Table XI Installation Recommendation

TSS Series No.	Rod Diameter d _N f8/h9			Groove Diameter D ₃ H9	Relief Diameter D ₄ H11	Groove Width L ₃ +.008	Radius r ₁	O-Ring Cross-Section d ₂
	Standard Application	Light Application	Heavy Duty Application					
WE20	.313 - .499	.500 - 5.125	-	d _N + .190	d _N + .060	.146	.015	.070
WE21	.500 - 2.499	2.500 - 9.625	.375 - .499	d _N + .270	d _N + .060	.196	.015	.103
WE22	2.500 - 9.999	10.000 - 15.750	1.000 - 2.499	d _N + .345	d _N + .060	.236	.015	.139
WE23	10.000 - 16.999	17.000 - 25.750	1.625 - 9.999	d _N + .480	d _N + .080	.332	.035	.210
WE24	17.000 - 19.999	20.000 - 25.750	4.375 - 16.999	d _N + .630	d _N + .080	.434	.035	.275

For diameters > 15.7 inches (400 mm) we recommend the use of Turcon® Excluder® 5.

Ordering Example

Turcon® Excluder® 2 with O-Ring, NBR
 Rod diameter: d_N = 2.500 inches
 Series: WE22 (from Table XI)
 TSS Part No.: WE2202500 (from Table XII)

TSS Article No.	WE22	02500	-	T46	N
TSS Series No.					
Rod diameter x 1000					
Quality Index					
Material Code (scraper)					
Material Code (O-Ring)					



Notes:

- 1) Tolerances used are per ISO-286 ISO System Of Limits and Fits. The tolerances are converted from metric and rounded to the nearest three place decimal.

Table XII Installation Dimensions / TSS Part No.

Rod Diam.	Groove Diam.	Groove Width	Relief Diam.	Step Width	TSS Part No.
d_N f8/h9	D_3 H9	L_3 +.008	D_4 h11	a min	
1.500	1.770	.196	1.560	.079	WE2101500
1.563	1.833	.196	1.623	.079	WE2101563
1.625	1.895	.196	1.685	.079	WE2101625
1.688	1.958	.196	1.748	.079	WE2101687
1.750	2.020	.196	1.810	.079	WE2101750
1.813	2.083	.196	1.873	.079	WE2101812
1.875	2.145	.196	1.935	.079	WE2101875
1.938	2.208	.196	1.998	.079	WE2101938
2.000	2.270	.196	2.060	.079	WE2102000
2.125	2.395	.196	2.185	.079	WE2102125
2.250	2.520	.196	2.310	.079	WE2102250
2.375	2.645	.196	2.435	.079	WE2102375
2.500	2.845	.236	2.560	.118	WE2202500
2.625	2.970	.236	2.685	.118	WE2202625
2.750	3.095	.236	2.810	.118	WE2202750
2.875	3.220	.236	2.935	.118	WE2202875
3.000	3.345	.236	3.060	.118	WE2203000
3.125	3.470	.236	3.185	.118	WE2203125
3.250	3.595	.236	3.310	.118	WE2203250
3.375	3.720	.236	3.435	.118	WE2203375
3.500	3.845	.236	3.560	.118	WE2203500
3.625	3.970	.236	3.685	.118	WE2203625
3.750	4.095	.236	3.810	.118	WE2203750
3.875	4.220	.236	3.935	.118	WE2203875
4.000	4.345	.236	4.060	.118	WE2204000
4.125	4.470	.236	4.185	.118	WE2204125
4.250	4.595	.236	4.310	.118	WE2204250
4.375	4.720	.236	4.435	.118	WE2204375
4.500	4.845	.236	4.560	.118	WE2204500
4.625	4.970	.236	4.685	.118	WE2204625

Other dimensions and all intermediate sizes up to 102 inches (2,600 mm) diameter can be supplied. The sizes listed in **bold** font are preferred sizes (more likely to be available for immediate shipment).



Rod Diam.	Groove Diam.	Groove Width	Relief Diam.	Step Width	TSS Part No.
d_N f8/h9	D_3 H9	L_3 +.008	D_4 h11	a min	
4.750	5.095	.236	4.810	.118	WE2204750
4.875	5.220	.236	4.935	.118	WE2204875
5.000	5.345	.236	5.060	.118	WE2205000
5.125	5.470	.236	5.185	.118	WE2205125
5.250	5.595	.236	5.310	.118	WE2205250
5.375	5.720	.236	5.435	.118	WE2205375
5.500	5.845	.236	5.560	.118	WE2205500
5.625	5.970	.236	5.685	.118	WE2205625
5.750	6.095	.236	5.810	.118	WE2205750
6.000	6.345	.236	6.060	.118	WE2206000
6.250	6.595	.236	6.310	.118	WE2206250
6.500	6.845	.236	6.560	.118	WE2206500
6.750	7.095	.236	6.810	.118	WE2206750
7.000	7.345	.236	7.060	.118	WE2207000
7.250	7.595	.236	7.310	.118	WE2207250
7.500	7.845	.236	7.560	.118	WE2207500
7.750	8.095	.236	7.810	.118	WE2207750
8.000	8.345	.236	8.060	.150	WE2208000
8.250	8.595	.236	8.310	.150	WE2208250
8.500	8.845	.236	8.560	.150	WE2208500
8.750	9.095	.236	8.810	.150	WE2208750
9.000	9.345	.236	9.060	.150	WE2209000
9.250	9.595	.236	9.310	.150	WE2209250
9.500	9.845	.236	9.560	.150	WE2209500
9.750	10.095	.236	9.810	.150	WE2209750
10.000	10.480	.332	10.080	.150	WE2310000
10.500	10.980	.332	10.580	.150	WE2310500
11.000	11.480	.332	11.080	.150	WE2311000
11.500	11.980	.332	11.580	.150	WE2311500
12.000	12.480	.332	12.080	.150	WE2312000
12.500	12.980	.332	12.580	.150	WE2312500
13.000	13.480	.332	13.080	.150	WE2313000
13.500	13.980	.332	13.580	.150	WE2313500
14.000	14.480	.332	14.080	.150	WE2314000
14.500	14.980	.332	14.580	.150	WE2314500
15.000	15.480	.332	15.080	.150	WE2315000

Other dimensions and all intermediate sizes up to 102 inches (2,600 mm) diameter can be supplied. The sizes listed in **bold** font are preferred sizes (more likely to be available for immediate shipment).



Turcon® Excluder® 2

Rod Diam.	Groove Diam.	Groove Width	Relief Diam.	Step Width	TSS Part No.
d_N f8/h9	D_3 H9	L_3 +.008	D_4 h11	a min	
15.500	15.980	.332	15.580	.150	WE2315500
16.000	16.480	.332	16.080	.150	WE2316000
16.500	16.980	.332	16.580	.150	WE2316500
17.000	17.630	.434	17.080	.150	WE2417000
17.500	18.130	.434	17.580	.150	WE2417500
18.000	18.630	.434	18.080	.150	WE2418000
18.500	19.130	.434	18.580	.150	WE2418500
19.000	19.630	.434	19.080	.150	WE2419000
19.500	20.130	.434	19.580	.150	WE2419500
20.000	20.630	.434	20.080	.150	WE2420000

Other dimensions and all intermediate sizes up to 102 inches (2,600 mm) diameter can be supplied.
The sizes listed in **bold** font are preferred sizes (more likely to be available for immediate shipment).

TURCON[®] EXCLUDER[®] 5



- Double-Acting -
- O-Ring-Energized Scraper -

- Material -
- Turcon[®] and Zurcon[®] -





■ Turcon® Excluder® 5

Description

The Turcon® Excluder® 5 is a patented double-acting scraper with two geometrically different scraper lips which are installed back-to-back. The scraper is installed together with an O-Ring as the elastic energizing element in one groove. The scraper function is performed by the Excluder® 5. The O-Ring maintains the pressure of the scraper lips against the sliding surface and can compensate for deflections of the piston rod.

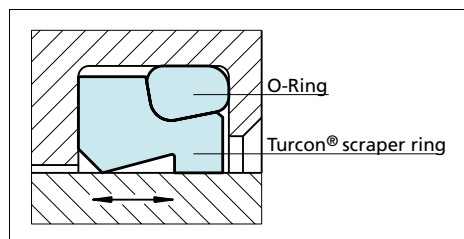

Figure 11 Turcon® Excluder® 5

The Excluder® 5 has two functions:

- Scrape contaminants from the retracting piston rod
- Hold back the residual oil film on the extending piston rod on the medium side

Excluder® 5 is preferably used with the Turcon® Stepseal®2K, our rod seal with a hydrodynamic back-pumping function. In contrast to the Excluder® 2, the Excluder® 5 is used for heavy duty applications such as construction machinery, presses, etc.

Advantages

- Outstanding sliding properties
- Stick-slip-free (Turcon® material)
- Tough scraper for heavy-duty operation
- Can compensate for deflections of the piston rod or plunger
- Very good scraping effect even against firmly adhered dirt, etc.
- Very good scraping effect from the inside against the residual oil film adhering to the surface of the piston rod

- Very high resistance to hydraulic media
- Available for all diameters up to 102.000 inches (2,600 mm) (Turcon®), up to 86.000 inches (2,200 mm) (Zurcon®)

Technical Data

Velocity:	50 ft/s (15 m/s) for Turcon® materials 6.5 ft/s (2 m/s) for Zurcon® materials
Temperature:	-49°F to +392°F (-45°C to +200°C) (Turcon®) -49°F to +212°F (-45°C to +100°C) (Zurcon®) (depending on O-Ring material)
Media:	Mineral oil-based hydraulic fluids, flame retardant hydraulic fluids, environmentally safe hydraulic fluids (bio-oils), water, air and others, depending on the scraper and O-Ring material

Important Note:

The above data are maximum values and cannot be used at the same time. e.g. the maximum operating speed depends on material type, pressure, temperature and gap value. Temperature range also dependent on medium.

Materials

The following material combination has proven effective for most applications:

Excluder®:	Turcon® T46
O-Ring:	NBR, 70 Shore A
Set Code:	T46N

For other applications, other material combinations as listed in Table XIII may also be used.

Design and Installation Instructions

Excluder® 5 scrapers can be installed in split and closed grooves (For installation dimensions, see table XIV).

Installation in closed grooves is depends on the rod diameter, profile cross-section of the scraper and on the cross section of the corresponding O-Ring.



Turcon® Excluder® 5

Table XIII Turcon® and Zurcon® Materials for Excluder® 5

Material, Applications, Properties	Code	O-Ring Material	Code	O-Ring Operating Temp. * °F	Mating Surface Material	Speed Ft/s max.
Turcon® T46 Standard material for hydraulics, high compressive strength, good sliding and wear properties, BAM tested. Bronze-filled Color: grayish to dark brown	T46	NBR - 70 Shore A	N	-22 to +212	Steel, hardened Steel, chrome-plated	50
		NBR - Low temp. 70 Shore A	T	-49 to +176		
		FKM - 70 Shore A	V	-14 to +392		
Turcon® T40 For all lubricating and non-lubricating hydraulic fluids, hydraulic oils without zinc, water hydraulic, soft mating surfaces. Surface texture not suitable for gases. Carbon fiber-filled Color: gray	T40	NBR - 70 Shore A	N	-22 to +212	Steel Steel, chrom-eplated Cast iron Stainless steel Aluminium Bronze Alloys	50
		NBR - Low temp. 70 Shore A	T	-49 to +176		
		FKM - 70 Shore A	V	-14 to +392		
		EPDM-70 Shore A	E**	-49 to +293		
Zurcon® Z52 For lubricating hydraulic fluids, high abrasion resistance. Cast polyurethane Color: turquoise	Z52	NBR - 70 Shore A	N	-22 to +212	Steel Steel, hardened Steel, chrome-plated Cast iron Stainless steel Ceramic coating Aluminium Bronze Alloys	6.5
		NBR - Low temp. 70 Shore A	T	-49 to +176		

* The O-Ring operation temperature is only valid in mineral hydraulic oil. BAM: Tested by Bundes Anstalt Materialprüfung, Germany.
 □ Highlighted materials are standard. ** Material not suitable for mineral oils.



Installation Recommendation (Inch Series)

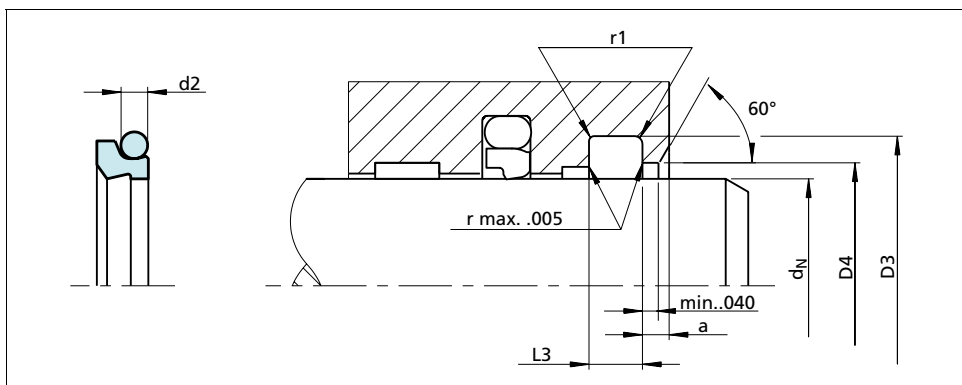

Figure 12 Installation drawing

Table XIV Installation Recommendation

TSS Series	Rod Diameter d_N f8/h9			Groove Diameter D_3 H9	Relief Diameter D_4 H11	Groove Width L_3 +.008	Radius r_1	O-Ring Cross-Section d_2
	Standard Application	Light Application	Heavy Duty Application					
WEE1	1.500 - 2.749	2.750 - 7.750	1.188 - 1.499	$d_N + .346$	$d_N + .060$.248	.015	.103
WEE2	2.750 - 5.499	5.500 - 13.750	-	$d_N + .480$	$d_N + .080$.319	.015	.139
WEE3	5.500 - 15.749	15.750 - 25.500	4.000 - 5.499	$d_N + .630$	$d_N + .100$.374	.035	.210
WEE4	15.750 - 25.500	-	7.875 - 15.749	$d_N + .945$	$d_N + .100$.551	.035	.275

Ordering example

Turcon® Excluder® 5 with O-Ring in NBR
 Rod diameter: $d_N = 2.500$ inches
 Series: WEE1 (from Table XIV)
 TSS Part No.: WEE102500 (from Table XV)

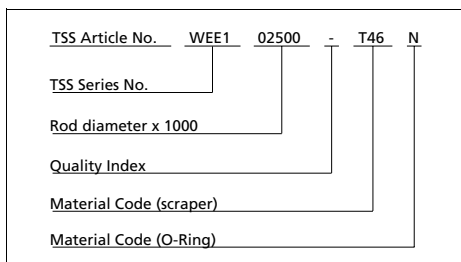



Table XV Installation Dimensions / TSS Part No.

Rod Diam.	Groove Diam.	Groove Width	Relief Diam.	Step Width	TSS Part No.
d_N f8/h9	D_3 H9	L_3 +.008	D_4 H11	a min.	
1.500	1.846	.248	1.560	.079	WEE101500
1.563	1.909	.248	1.623	.079	WEE101563
1.625	1.971	.248	1.685	.079	WEE101625
1.688	2.034	.248	1.748	.079	WEE101687
1.750	2.096	.248	1.810	.079	WEE101750
1.813	2.159	.248	1.873	.079	WEE101812
1.875	2.221	.248	1.935	.079	WEE101875
1.938	2.284	.248	1.998	.079	WEE101938
2.000	2.346	.248	2.060	.079	WEE102000
2.125	2.471	.248	2.185	.079	WEE102125
2.250	2.596	.248	2.310	.079	WEE102250
2.375	2.721	.248	2.435	.079	WEE102375
2.500	2.846	.248	2.560	.079	WEE102500
2.625	2.971	.248	2.685	.079	WEE102625
2.750	3.230	.319	2.810	.079	WEE202750
2.875	3.355	.319	2.955	.118	WEE202875
3.000	3.480	.319	3.080	.118	WEE203000
3.125	3.605	.319	3.205	.118	WEE203125
3.250	3.730	.319	3.330	.118	WEE203250
3.375	3.855	.319	3.455	.118	WEE203375
3.500	3.980	.319	3.580	.118	WEE203500
3.625	4.105	.319	3.705	.118	WEE203625
3.750	4.230	.319	3.830	.118	WEE203750
3.875	4.355	.319	3.955	.118	WEE203875
4.000	4.480	.319	4.080	.118	WEE204000
4.125	4.605	.319	4.205	.118	WEE204125
4.250	4.730	.319	4.330	.118	WEE204250
4.375	4.855	.319	4.455	.118	WEE204375
4.500	4.980	.319	4.580	.118	WEE204500
4.625	5.105	.319	4.705	.118	WEE204625
4.750	5.230	.319	4.830	.118	WEE204750
4.875	5.355	.319	4.955	.118	WEE204875
5.000	5.480	.319	5.080	.118	WEE205000

The sizes listed in **bold** font are preferred sizes (more likely to be available for immediate shipment). Other dimensions and all intermediate sizes up to 102 inches (2,600 mm) diameter can be supplied.



Rod Diam.	Groove Diam.	Groove Width	Relief Diam.	Step Width	TSS Part No.
d_N f8/h9	D_3 H9	L_3 +.008	D_4 H11	a min.	
5.125	5.605	.319	5.205	.118	WEE205125
5.250	5.730	.319	5.330	.118	WEE205250
5.375	5.855	.319	5.455	.118	WEE205375
5.500	6.130	.374	5.580	.118	WEE305500
5.625	6.255	.374	5.725	.118	WEE305625
5.750	6.380	.374	5.850	.118	WEE305750
6.000	6.630	.374	6.100	.118	WEE306000
6.250	6.880	.374	6.350	.118	WEE306250
6.500	7.130	.374	6.600	.118	WEE306500
6.750	7.380	.374	6.850	.118	WEE306750
7.000	7.630	.374	7.100	.118	WEE307000
7.250	7.880	.374	7.350	.118	WEE307250
7.500	8.130	.374	7.600	.118	WEE307500
7.750	8.380	.374	7.850	.118	WEE307750
8.000	8.630	.374	8.100	.150	WEE308000
8.250	8.880	.374	8.350	.150	WEE308250
8.500	9.130	.374	8.600	.150	WEE308500
8.750	9.380	.374	8.850	.150	WEE308750
9.000	9.630	.374	9.100	.150	WEE309000
9.250	9.880	.374	9.350	.150	WEE309250
9.500	10.130	.374	9.600	.150	WEE309500
9.750	10.380	.374	9.850	.150	WEE309750
10.000	10.630	.374	10.100	.150	WEE310000
10.500	11.130	.374	10.600	.150	WEE310500
11.000	11.630	.374	11.100	.150	WEE311000
11.500	12.130	.374	11.600	.150	WEE311500
12.000	12.630	.374	12.100	.150	WEE312000
12.500	13.130	.374	12.600	.150	WEE312500
13.000	13.630	.374	13.100	.150	WEE313000
13.500	14.130	.374	13.600	.150	WEE313500
14.000	14.630	.374	14.100	.150	WEE314000
14.500	15.130	.374	14.600	.150	WEE314500
15.000	15.630	.374	15.100	.150	WEE315000
15.500	16.130	.374	15.600	.150	WEE315500
16.000	16.945	.551	16.100	.150	WEE416000
16.500	17.445	.551	16.600	.150	WEE416500

The sizes listed in **bold** font are preferred sizes (more likely to be available for immediate shipment). Other dimensions and all intermediate sizes up to 102 inches (2,600 mm) diameter can be supplied.



Turcon® Excluder® 5

Rod Diam.	Groove Diam.	Groove Width	Relief Diam.	Step Width	TSS Part No.
d_N f8/h9	D_3 H9	L_3 +.008	D_4 H11	a min.	
17.000	17.945	.551	17.100	.150	WEE417000
17.500	18.445	.551	17.600	.150	WEE417500
18.000	18.945	.551	18.100	.150	WEE418000
18.500	19.445	.551	18.600	.150	WEE418500
19.000	19.945	.551	19.100	.150	WEE419000
19.500	20.445	.551	19.600	.150	WEE419500
20.000	20.945	.551	20.100	.150	WEE420000

The sizes listed in **bold** font are preferred sizes (more likely to be available for immediate shipment). Other dimensions and all intermediate sizes up to 102 inches (2,600 mm) diameter can be supplied.

ZURCON[®] SCRAPER WAE

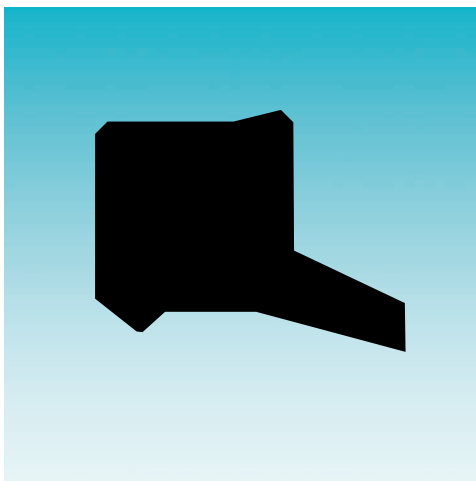

- Single-Acting -

- Material -

- Zurcon[®] Polyurethane -





■ Zurcon® Scraper WAE

Description

The WAE is a single-acting polyurethane scraper.

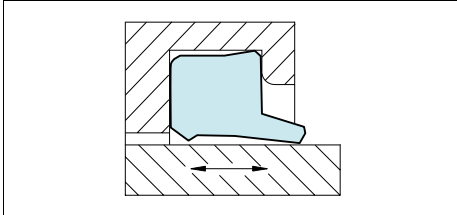

Figure 13 Scraper WAE

The special feature of this scraper is an additional support on the inner surface. It prevents tilting or twisting of the scraper in the groove. At the same time this support improves the firm seating in the groove, preventing the penetration of impurities via the back of the scraper. This represents a technical improvement compared to similar scraper types.

Advantages

- Simple groove design
- Very good scraping effect, wear-resistant
- No tilting or twisting in the groove
- Simple installation
- Flush fitting with the outer surface

Technical Data

Velocity:	Up to 3 ft/s (1 m/s)
Temperature:	-31°F to +212°F (-35°C to +100°C)
Media:	Mineral oil-based hydraulic fluids

Important Note:

The above data are maximum values and cannot be used at the same time. e.g. the maximum operating speed depends on material type, pressure, temperature and gap value. Temperature range also dependent on medium.

Material

The standard material is a wear-resistant Zurcon® polyurethane.

Standard material:	Polyurethane, 93 Shore A Material No. Z201
Color:	Turquoise



Installation Recommendation (Inch Series)

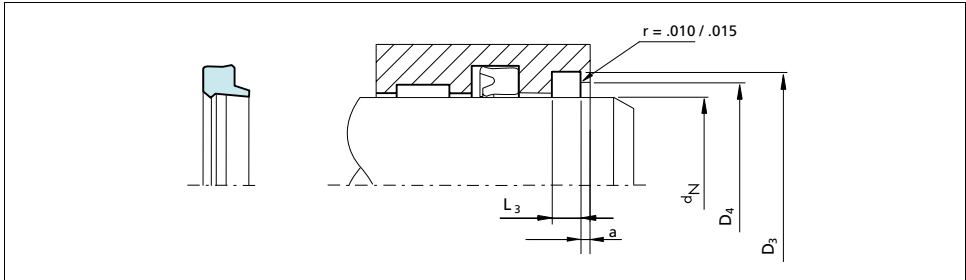

Figure 14 Installation drawing

Table XVI Installation Recommendation

TSS Series	Rod Diameter	Groove Diameter	Relief Diameter	Groove Width
	d_N f8/h9	D_3 H9	D_4 h11	L_3 +.015
WAE1	.250 - .687	d_N +.250	d_N +.160	.125
WAE2	.688 - 1.999	d_N +.375	d_N +.240	.187
WAE3	2.000 - 4.375	d_N +.500	d_N +.325	.250
WAE4	3.625 - 4.375	d_N +.625	d_N +.405	.312
WAE5	4.376 - 8.000	d_N +.750	d_N +.485	.375
WAE6	7.000 - 10.000	d_N +1.000	d_N +.650	.500

Ordering Example

Scraper WAE
 Rod diameter: $d_N = 2.500$ inches
 TSS Part No.: WAE302500 (from Table XVII)
 Material: Z201

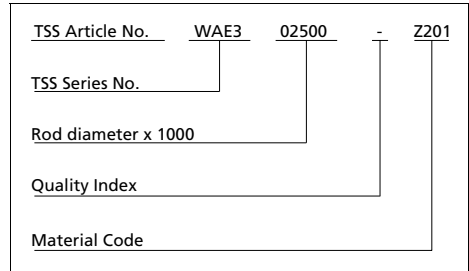

Notes:

- 1) Tolerances used are per ISO-286 ISO System Of Limits and Fits. The tolerances are converted from metric and rounded to the nearest three place decimal.
- 2) Grooves are ISO 6195 Type D to the nearest inch size and typical to industry standards



Table XVII Installation Dimensions / TSS Part No.

Rod Diam.	Groove Diam.	Groove Width	Relief Diam.	Step Width	TSS Part No.
d_N f8/h9	D_3 H9	L_3 +.008	D_4 h11	a min	
.500	.750	.125	.660	.079	WAE100500
.625	.875	.125	.785	.079	WAE100625
.750	1.125	.187	.995	.079	WAE200750
.875	1.250	.187	1.120	.079	WAE200875
1.000	1.375	.187	1.245	.079	WAE201000
1.125	1.500	.187	1.370	.079	WAE201125
1.250	1.625	.187	1.497	.079	WAE201250
1.375	1.750	.187	1.622	.079	WAE201375
1.500	1.875	.187	1.747	.079	WAE201500
1.625	2.000	.187	1.872	.079	WAE201625
1.750	2.125	.187	1.997	.079	WAE201750
1.875	2.250	.187	2.122	.079	WAE201875
2.000	2.500	.250	2.327	.079	WAE302000
2.125	2.625	.250	2.452	.079	WAE302125
2.250	2.750	.250	2.577	.079	WAE302250
2.375	2.875	.250	2.702	.079	WAE302375
2.500	3.000	.250	2.827	.079	WAE302500
2.625	3.125	.250	2.952	.079	WAE302625
2.750	3.250	.250	3.077	.079	WAE302750
2.875	3.375	.250	3.202	.079	WAE302875
3.000	3.500	.250	3.327	.079	WAE303000
3.250	3.750	.250	3.577	.079	WAE303250
3.500	4.000	.250	3.827	.079	WAE303500
3.750	4.250	.250	4.077	.079	WAE303750
3.875	4.375	.250	4.202	.079	WAE303875
4.000	4.500	.250	4.327	.079	WAE304000
4.250	4.750	.250	4.577	.079	WAE304250
4.500	5.250	.375	4.993	.079	WAE504500
4.750	5.500	.375	5.243	.079	WAE504750
5.000	5.750	.375	5.493	.079	WAE505000
5.250	6.000	.375	5.743	.079	WAE505250
5.500	6.250	.375	5.993	.079	WAE505500
5.750	6.500	.375	6.243	.079	WAE505750

The sizes listed in **bold** font are preferred sizes (more likely to be available for immediate shipment). Other dimensions and all intermediate sizes up to 10 inches (250 mm) diameter can be supplied. A split groove is required up to 0.600 inches (14 mm) diameter.



Zurcon® Scraper WAE

Rod Diam.	Groove Diam.	Groove Width	Relief Diam.	Step Width	TSS Part No.
d_N f8/h9	D_3 H9	L_3 +.008	D_4 h11	a min	
6.000	6.750	.375	6.493	.079	WAE506000
6.250	7.000	.375	6.743	.079	WAE506250
6.500	7.250	.375	6.993	.079	WAE506500
6.750	7.500	.375	7.243	.079	WAE506750
7.000	7.750	.375	7.493	.079	WAE507000
7.500	8.250	.375	7.993	.079	WAE507500
8.000	8.750	.375	8.493	.079	WAE508000

The sizes listed in **bold** font are preferred sizes (more likely to be available for immediate shipment). Other dimensions and all intermediate sizes up to 10 inches (250 mm) diameter can be supplied. A split groove is required up to 0.600 inches (14 mm) diameter.

SCRAPER WRM

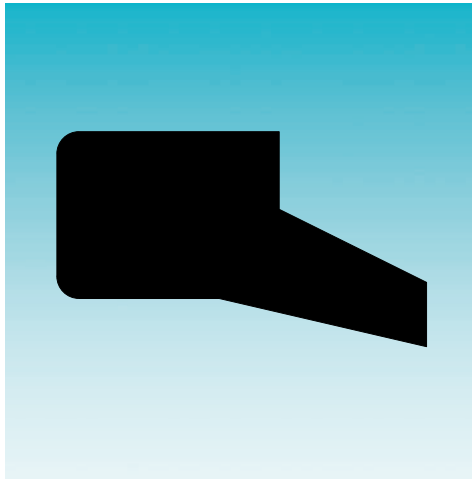

- Single-Acting -

- Material -

- NBR Elastomer -





■ Scraper WRM

Description

Wipers are essential components of any hydraulic or pneumatic equipment.

These are protection components for axial moving rods; they ensure that foreign matter is not introduced into the system, avoiding costly wear and damage to all the internal components including seals.

WRM scrapers are manufactured in nitrile elastomer with precision machined wiper lip, which produces a very effective wiping action.

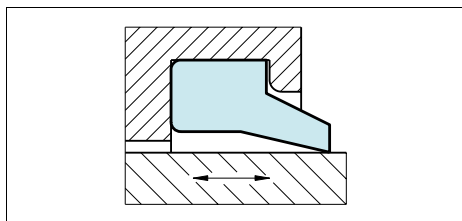

Figure 16 Scraper WRM

Advantages

- Space-saving construction
- Low cost, economical solution
- Simple, easy construction groove
- Easy installation and removal without tools

Application Examples

Due to their outstanding wiping capacities WRM scrapers are recommended wherever there are dusty and humid conditions and especially for the following applications:

- Valve spindles
- Slide valves
- Hydraulic cylinders
- Agriculture machinery

Technical Data

Operating conditions

Velocity: Up to 3 ft/s (1 m/s)

Temperature: -31°F to +230°F (-30°C to +110°C)

Media: Mineral oil-based hydraulic fluids, polyglycol-water emulsions, water-oil emulsions

Groove type: Closed

Important Note:

The above data are maximum values and cannot be used at the same time. e.g. the maximum operating speed depends on material type, pressure, temperature and gap value. Temperature range also dependent on medium.

Materials

Standard application:

Nitrile elastomer NBR 90 Shore A

Material code: N9



Scraper WRM

Installation Recommendation (Inch Series)

Ordering Example

Rod diameter: $d_N = 2.500$ inches
 TSS Part No.: WAP000635
 Material Code: N9T60 (standard)

TSS Article No.	WAP0	00635	-	N9
TSS Series No.				
Metric rod diameter x 10				
Quality Index				
Material Code				

Table XIX Installation Dimensions / TSS Part No.

Rod Diam.	Groove Diam.	Groove Width	Relief Diam.	TSS Part No.
d_N f8/h9	D_3 H9	L_3 +.015	D_4 h11	
.500	.760	.150	.618	WAP000127
.750	1.010	.150	.868	WAP000191
1.000	1.339	.209	1.118	WAP000254
1.250	1.589	.209	1.368	WAP000318
1.500	1.839	.209	1.618	WAP000381
1.750	2.089	.209	1.868	WAP000445
2.000	2.339	.209	2.118	WAP000508
2.250	2.589	.209	2.368	WAP000572
2.500	2.839	.209	2.618	WAP000635
2.750	3.089	.209	2.868	WAP000699
3.000	3.339	.209	3.118	WAP000762
3.250	3.589	.209	3.368	WAP000826
3.500	3.839	.209	3.618	WAP000889
3.750	4.089	.209	3.868	WAP000953
4.000	4.480	.279	4.236	WAP001016
4.500	4.980	.279	4.736	WAP001143
5.000	5.480	.279	5.236	WAP001270
5.500	5.980	.279	5.736	WAP001397
6.000	6.480	.279	6.236	WAP001524

Other dimensions and all intermediate sizes up to 20 inches (508 mm) diameter can be supplied.
 The sizes listed in **bold** font are preferred sizes (more likely to be available for immediate shipment).

ZURCON[®] SCRAPER SWP

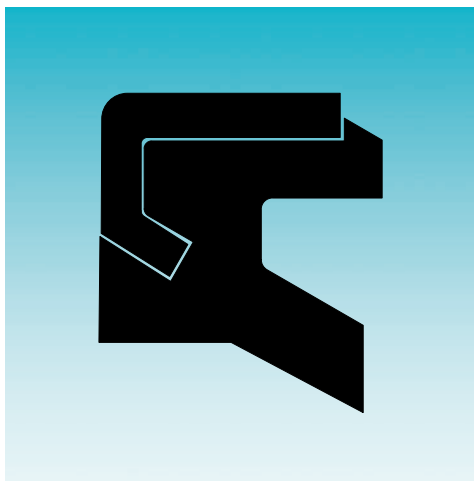

- Single-Acting -
- Metal-Encased Wiper -

- Material -
- Zurcon[®] Polyurethane + Metal -





■ Zurcon® Scraper SWP

Description

The SWP is a polyurethane single-lipped scraper with integrated metal reinforcement for open groove assembly. It is typically used in severe applications where there is abrasion due to solid matter on the rod surface.

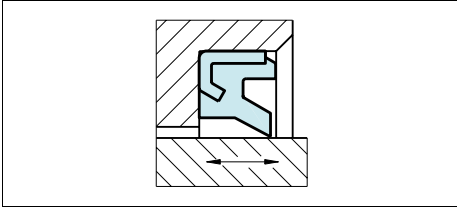

Figure 18 Scraper SWP

Advantages

- Space-saving construction
- Simple small installation groove
- Firm fit in the groove due to metallic press fit
- At regreasing of drag bearing, the scraper lip opens at low overpressure; old grease can escape
- High wear resistance / long life

Application Examples

Due to their outstanding wiping capacities SWP scrapers are recommended wherever there are dusty and humid conditions and especially for the following applications:

- Mobile hydraulic machinery
- Construction machinery
- Link pin seals
- Lift trucks
- Truck cargo cranes
- Agriculture machinery

Technical Data

Operating conditions

Velocity:	Up to 3 ft/s (1 m/s)
Temperature:	-31°F to +212°F (-35°C to +100°C)
Media:	Mineral oil-based hydraulic fluids
Groove type:	Open

Important Note:

The above data are maximum values and cannot be used at the same time. e.g. the maximum operating speed depends on material type, pressure, temperature and gap value. Temperature range also dependent on medium.

Materials

Standard application

Zurcon® Polyurethane:	93 Shore A
Color:	Turquoise
Metal case:	Non-alloyed steel DIN 1624
Material set code:	Z2022



Installation Recommendation (Inch Series)

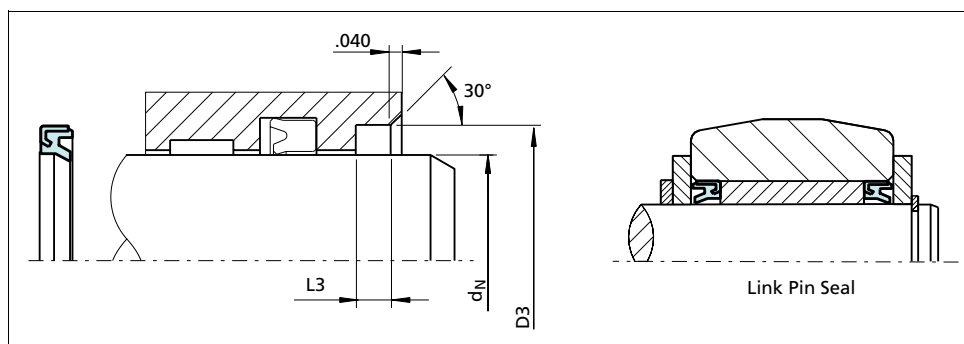

Figure 19 Installation drawing

Table XX Installation Recommendation

TSS Series	Rod Diameter	Groove Diameter	Groove Width
	d_N f8/h9	D_3 H9	L_3 +.015
WSKCB	.50 - 2.00	d_N +.500	.250
WSKCC	.75 - 3.00	d_N +.500	.313
WSKDC	2.50 - 5.25	d_N +.625	.313
WSKDD	3.00 - 6.00	d_N +.625	.375
WSKED	4.00 - 7.00	d_N +.750	.375
WSKFF	5.00 -10.0	d_N +1.000	.500

Ordering Example

Rod diameter: d_N = 2.500 inches
 Groove diameter: D_3 = 3.000 inches
 TSS Part No.: WSKCC02500
 Material set code: Z2022 (standard)

TSS Article No.	WSKCC	02500	-	Z2022
TSS Series No.				
Rod diameter x 1000				
Quality Index				
Material Code				

Notes:

1) Tolerances used are per ISO-286 ISO System Of Limits and Fits. The tolerances are converted from metric and rounded to the nearest three place decimal.



Table XXI Installation Dimensions / TSS Part No.

Rod Diam.	Groove Diam.	Groove Width	TSS Part No.
d_N f8/h9	D₃ H8	L₃ +.015	
1.000	1.500	.250	WSKCB1000
1.125	1.625	.313	WSKCC1125
1.250	1.750	.313	WSKCC1250
1.375	1.875	.313	WSKCC1375
1.500	2.000	.313	WSKCC1500
1.625	2.125	.313	WSKCC1625
1.750	2.250	.313	WSKCC1750
1.875	2.375	.313	WSKCC1875
2.000	2.500	.313	WSKCC2000
2.250	2.750	.313	WSKCC2250
2.500	3.000	.313	WSKCC2500
2.750	3.250	.313	WSKCC2750
3.000	3.500	.313	WSKCC3000
3.250	3.875	.313	WSKDC3250
3.500	4.125	.313	WSKDC3500
3.750	4.375	.313	WSKDC3750
4.000	4.625	.313	WSKDC4000
4.250	4.875	.313	WSKDC4250
4.500	5.125	.313	WSKDC4500
4.750	5.375	.313	WSKDC4750
5.000	5.625	.375	WSKDD5000
5.250	5.875	.375	WSKDD5250
5.500	6.125	.375	WSKDD5500
6.000	6.625	.375	WSKDD6000
7.000	8.000	.500	WSKFF7000
8.000	9.000	.500	WSKFF8000

The sizes listed in **bold** font are preferred sizes (more likely to be available for immediate shipment).

Other dimensions and all intermediate sizes up to 10 inches (250 mm) diameter can be supplied.



SCRAPER WSA

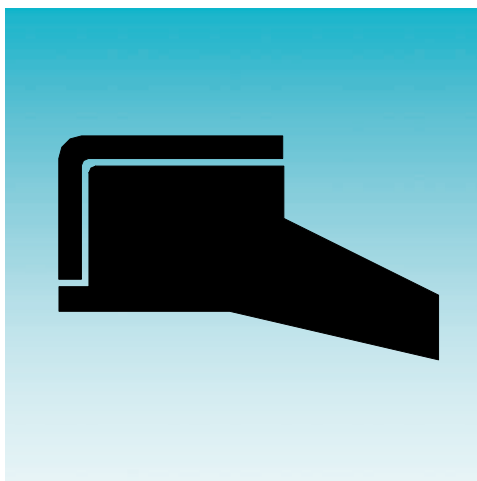

- Single-Acting -
- Metal-Encased Wiper -

- Material -
- NBR and Metal -





■ Scraper WSA

Description

The WSA is a mold-vulcanized single-acting elastomer scraper with integral metal reinforcement for open groove assembly. In conjunction with the scraper interference, an exact fit is obtained in the housing.

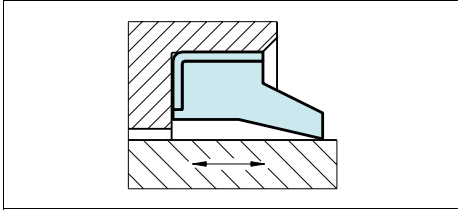

Figure 20 Scraper WSA

Advantages

- Space-saving construction
- Low cost, economical solution
- Simple, easy construction groove
- Firm fit in the groove due to metallic press fit

Application Examples

- Hydraulic cylinders
- Agriculture machinery
- Construction machinery
- Lift trucks
- Mobile hydraulics

Technical Data

Operating conditions

Velocity: Up to 3 ft/s (1 m/s)

Temperature: -22° F to +230° F (-30° C to +110° C)

Media: Mineral oil-based hydraulic fluids, polyglycol-water emulsions, water-oil emulsions

Groove type: Open

Important Note:

The above data are maximum values and cannot be used at the same time. e.g. the maximum operating speed depends on material type, pressure, temperature and gap value. Temperature range also dependent on medium.

Materials

Standard application:

Material: NBR 90 Shore A + Metal

TSS code: N9MN



Installation Recommendation (Inch Series)

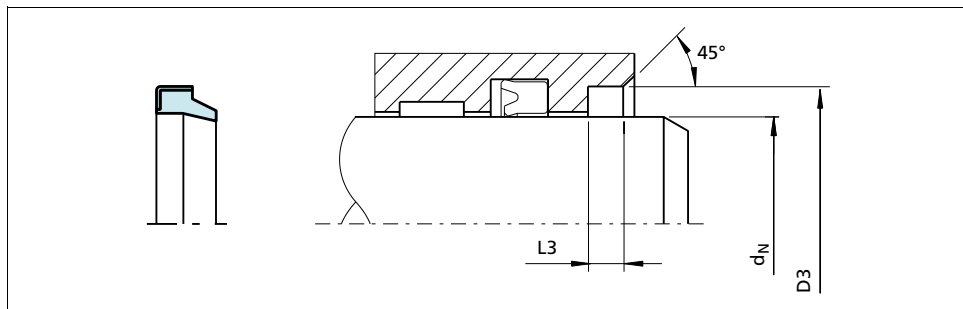

Figure 21 Installation drawing

Table XXII Installation Recommendation

TSS Series	Rod Diameter d_N f8/h9		Groove Diameter D_3 H9	Groove Width L_3 +.015
	Standard Application	Light Application		
WSF2	.500 - 1.000	1.001 - 2.000	d_N +.500	.250
WSF3	1.001 - 3.000	-	d_N +.500	.313
WSF4	3.001 - 4.750	4.751 - 5.250	d_N +.625	.313
WSF5	4.751 - 6.000	-	d_N +.625	.375
WSF6	-	4.000 - 7.000	d_N +.750	.375
WSF7	6.001 - 8.000	8.001 - 10.000	d_N +1.000	.500

Ordering Example

Rod diameter: $d_N = 2.500$ inches
 Groove diameter: $D_3 = 3.000$ inches
 TSS Part No.: WSF302500

Material set code:
 TSS: N9MN

TSS Article No.	WSF3	02500	-	N9MN
TSS Series No.				
Rod diameter x 1000				
Quality Index				
Material Set Code				

Notes:

- 1) Tolerances used are per ISO-286 ISO System Of Limits and Fits. The tolerances are converted from metric and rounded to the nearest three place decimal.



Table XXIII Installation Dimensions / TSS Part No.

Rod Diam.	Groove Diam.	Groove Width	TSS Part No.
d_N f8/h9	D_3 H8	L_3 +.015	
.500	1.000	.250	WSF200500
.563	1.063	.250	WSF200563
.625	1.125	.250	WSF200625
.688	1.188	.250	WSF200688
.750	1.250	.250	WSF200750
.813	1.313	.250	WSF200813
.875	1.375	.250	WSF200875
.938	1.438	.250	WSF200938
1.000	1.500	.250	WSF201000
1.063	1.563	.313	WSF301062
1.125	1.625	.313	WSF301125
1.188	1.688	.313	WSF301188
1.250	1.750	.313	WSF301250
1.313	1.813	.313	WSF301313
1.375	1.875	.313	WSF301375
1.438	1.938	.313	WSF301438
1.500	2.000	.313	WSF301500
1.563	2.063	.313	WSF301563
1.625	2.125	.313	WSF301625
1.688	2.188	.313	WSF301688
1.750	2.250	.313	WSF301750
1.813	2.313	.313	WSF301813
1.875	2.375	.313	WSF301875
1.938	2.438	.313	WSF301938
2.000	2.500	.313	WSF302000
2.125	2.625	.313	WSF302125
2.250	2.750	.313	WSF302250
2.375	2.875	.313	WSF302375
2.500	3.000	.313	WSF302500
2.625	3.125	.313	WSF302625
2.750	3.250	.313	WSF302750
2.875	3.375	.313	WSF302875
3.000	3.500	.313	WSF303000
3.125	3.750	.313	WSF403125
3.250	3.875	.313	WSF403250
3.375	4.000	.313	WSF403375

Rod Diam.	Groove Diam.	Groove Width	TSS Part No.
d_N f8/h9	D_3 H8	L_3 +.015	
3.500	4.125	.313	WSF403500
3.625	4.250	.313	WSF403625
3.750	4.375	.313	WSF403750
3.875	4.500	.313	WSF403875
4.000	4.625	.313	WSF404000
4.125	4.750	.313	WSF404125
4.250	4.875	.313	WSF404250
4.375	5.000	.313	WSF404375
4.500	5.125	.313	WSF404500
4.625	5.250	.313	WSF404625
4.750	5.375	.313	WSF404750
4.875	5.500	.313	WSF404875
5.000	5.625	.375	WSF505000
5.125	5.750	.375	WSF505125
5.250	5.875	.375	WSF505250
5.375	6.000	.375	WSF505375
5.500	6.125	.375	WSF505500
5.625	6.250	.375	WSF505625
5.750	6.375	.375	WSF505750
6.000	6.625	.375	WSF506000
6.250	6.875	.375	WSF506250
6.500	7.500	.500	WSF506500
6.750	7.750	.500	WSF506750
7.000	8.000	.500	WSF507000
7.250	8.250	.500	WSF507250
7.500	8.500	.500	WSF507500
7.750	8.750	.500	WSF507750
8.000	9.000	.500	WSF508000

Other dimensions and all intermediate sizes up to 20 inches (508 mm) diameter can be supplied. The sizes listed in **bold** font are preferred sizes (more likely to be available for immediate shipment).



Scraper WSA

METAL SCRAPER

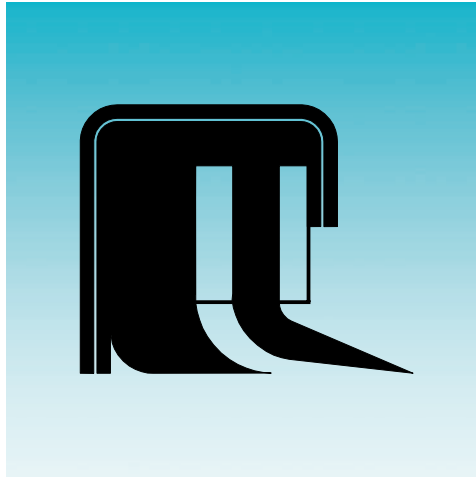

- Single-Acting -
- Metal and Elastomer Scraper Lips -

- Material -
- NBR, Metal and Brass -





■ Metal Scraper

Description

The metal scraper is a single-acting special scraper with two different scraper lips - a thin metallic lip and an elastomer lip. The two scraper lips are arranged in tandem behind one another in a compact metal housing.

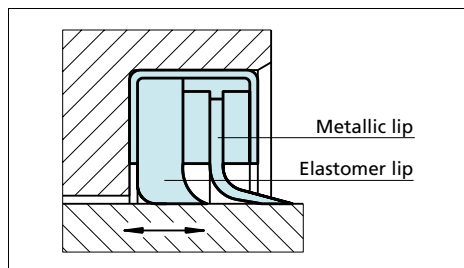

Figure 22 Metal Scraper

The metal scraper lip is designed to remove firmly adhered soil and ice particles. The secondary lip of elastomer material enhances the overall scraping effect, i.e. fine sand grains, water and similar foreign matter are reliably scraped off. Both scraper lips have a smaller diameter than the nominal diameter of the piston rod, ensuring a tight fit. The metallic lip is guided in the radial direction and can easily follow any possible deflections of the piston rod.

Advantages

- Very good scraping effect, even with firmly adhering dirt, e.g. mud, ice
- Very abrasion resistant
- Tight fit in the groove due to the metal case
- Easy installation in open grooves

Technical Data

Velocity:	Max. 3 ft/s (1 m/s) with reciprocating movements
Temperature:	-22°F to +248°F (-30°C to +120°C)
Media:	Mineral oil-based hydraulic fluids, flame retardant hydraulic fluids (HFA, HFB, HFC), water, air, etc.

Important Note:

The above data are maximum values and cannot be used at the same time. e.g. the maximum operating speed depends on material type, pressure, temperature and gap value. Temperature range also dependent on medium.

Materials

Inner scraper lip:	Nitrile, NBR, 70 Shore A Code N7
Metal housing:	Sheet metal 1.0204 (AISI 1008) or similar Code M
Outer scraper lip:	Brass Code S

Other materials for scraper lips and housing available on request.



Metal Scraper

Installation Recommendation (Inch Series)

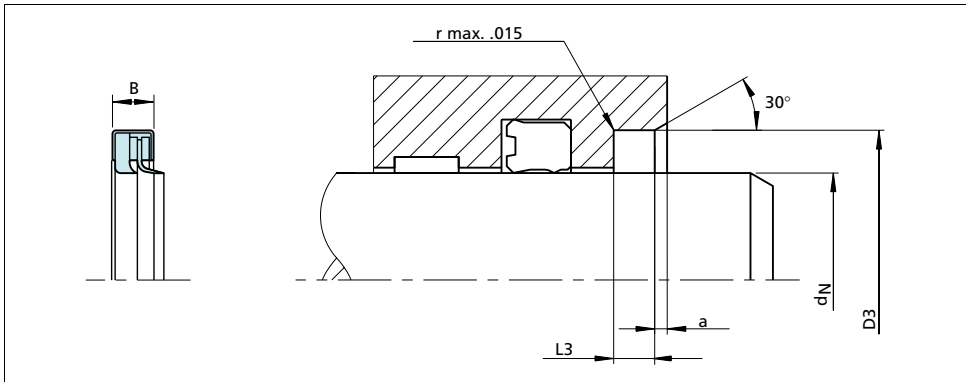

Figure 23 Installation drawing

Ordering Example

Metal scraper
 Rod diameter: $d_N = 2.500\text{in}$
 Groove diameter: $D_3 = 3.000\text{in}$
 Groove width: $L_3 = .201\text{in}$
 TSS Part No.: WMC504277 (from Table XXIV)
 Material: Standard materials
 Material code N7MS

TSS Article No.	WMC504277	-	N7	M	S
TSS Part No.					
Quality Index					
Material code (inner scraper lip)					
Material code (housing)					
Material code (outer scraper lip)					

Table XXIV Installation Dimensions / TSS Part No.

Rod Diam.	Groove Diam.	Groove Width	Chamfer	Width	TSS Part No.
d_N f8/h9	D_3 H8	L_3 +.010	a min	B	
.500	1.000	.170	.080	.250	WMC504260
.625	1.125	.201	.080	.281	WMC504261
.750	1.250	.201	.080	.281	WMC504262
.875	1.375	.201	.080	.281	WMC504263
1.000	1.500	.201	.080	.281	WMC504264
1.125	1.625	.201	.080	.281	WMC504265

Other dimensions and all intermediate sizes up to 10 inches (250 mm) diameter can be supplied.
 The sizes listed in **bold** font are preferred sizes (more likely to be available for immediate shipment).

Metal Scraper



Rod Diam.	Groove Diam.	Groove Width	Chamfer	Width	TSS Part No.
d_N f8/h9	D_3 H8	L_3 +.010	a min	B	
1.250	1.750	.201	.080	.281	WMC504266
1.375	1.875	.201	.080	.281	WMC504267
1.500	2.000	.201	.080	.281	WMC504268
1.625	2.125	.201	.080	.281	WMC504269
1.750	2.250	.201	.080	.281	WMC504270
1.875	2.375	.201	.080	.281	WMC504271
2.000	2.500	.201	.080	.281	WMC504272
2.125	2.625	.201	.080	.281	WMC504274
2.250	2.750	.201	.080	.281	WMC504275
2.375	2.875	.201	.080	.281	WMC504276
2.500	3.000	.201	.080	.281	WMC504277
2.625	3.125	.201	.080	.281	WMC504278
2.750	3.250	.201	.080	.281	WMC504279
2.875	3.375	.201	.080	.281	WMC504280
3.000	3.500	.201	.080	.281	WMC504281
3.125	3.750	.208	.120	.328	WMC504282
3.250	3.875	.208	.120	.328	WMC504283
3.375	4.000	.208	.120	.328	WMC504284
3.500	4.125	.208	.120	.328	WMC504285
3.625	4.250	.208	.120	.328	WMC504286
3.750	4.375	.208	.120	.328	WMC504287
3.875	4.500	.208	.120	.328	WMC504288
4.000	4.625	.208	.120	.328	WMC504289
4.125	4.750	.208	.120	.328	WMC504290
4.250	4.875	.208	.120	.328	WMC504291
4.375	5.000	.208	.120	.328	WMC504292
4.500	5.125	.208	.120	.328	WMC504293
4.750	5.375	.208	.120	.328	WMC504294
5.000	5.625	.208	.120	.328	WMC504295
5.250	5.875	.208	.120	.328	WMC504296
5.500	6.125	.239	.120	.359	WMC504297
6.000	7.000	.239	.120	.359	WMC504825

Other dimensions and all intermediate sizes up to 10 inches (250 mm) diameter can be supplied. The sizes listed in **bold** font are preferred sizes (more likely to be available for immediate shipment).



Metal Scraper

SLYDRING® - WEAR RINGS

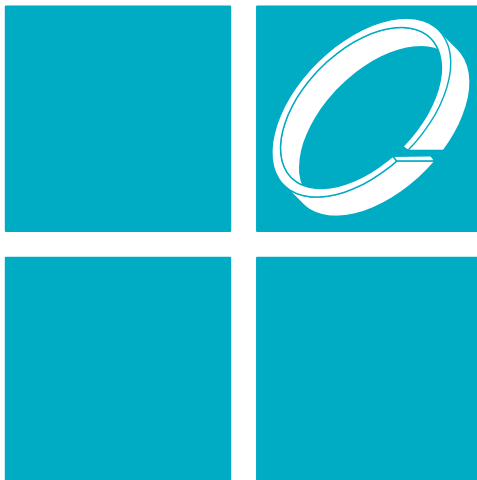





Contents

Choice of Slydring®	4
Design Instructions	7
Turcite® and Zurcon® Slydring® for Piston and Rod	8
HiMod® Slydring® for Piston and Rod	10
Orkot® Slydring® for Piston and Rod	12
Installation and Part Numbers for Piston	13
Installation and Part Numbers for Rod	19



Choice of Slydring®

The function of Slydring® is to absorb the sideload forces which occur in the piston and/or rod of a hydraulic cylinder or other devices. At the same time they eliminate metallic contact between the sliding parts of the cylinder, e.g. piston and cylinder barrel or rod and cylinder head. Non-metallic guide rings offer major benefits compared with the traditional metallic guides:

- Cost efficient production
- High load bearing capacity
- Eliminates local stress concentrations
- Wear-resistant, long service lives
- Metal/plastic pairing eliminates fretting and seizure
- Favourable friction behaviour
- Damping of mechanical vibrations
- Good wiping effect, embedding of foreign particles possible
- Protection of the seal against "dieseling"
- Free choice of material of the metal components as guiding properties are no longer required
- Eliminates hydrodynamic pressure problems in the guide system
- Simple closed groove, easy installation
- Low service costs

Materials

In view of the different specific demands made on piston and rod guides, various Slydring® materials are available:

- Turcite® materials are highly wear-resistant, low friction, specially modified materials for low to medium duty with limited radial forces
- HiMod® materials with friction-reducing fillers for medium to heavy duty radial forces
- Orkot® fabric composite materials for heavy duty and high radial forces

In order to choose the most suitable Slydring®, it is first necessary to know all the required functional parameters. Table I can be used to make an initial preselection of the Slydring® and the materials to meet the demands of the application.

Before the final choice of Slydring® and material is made, the details and information must be checked in the relevant data sheets of Slydring® materials.

Design type

Slydring® have a rectangular cross-section with rounded or chamfered edges, thus preventing impermissible edge forces in the corner radii of the grooves. The chamfers also serve to facilitate installation, e.g. when inserting into the cylindrical tube or guide bush.

Slydring® is supplied ready to fit with the gap necessary (dimension Z or Z1) for their function. The ring ends are finished as standard with an angle cut.

For further details, please refer to Table .

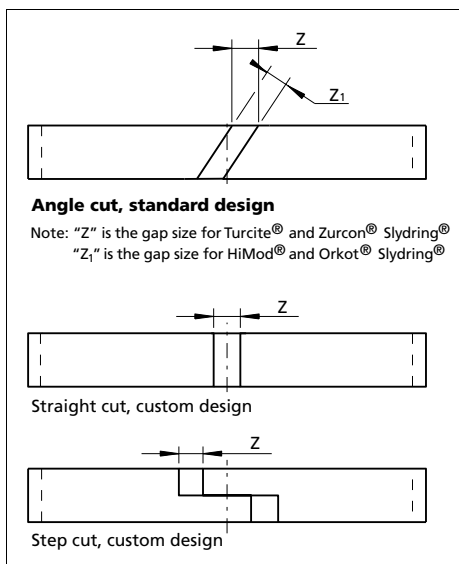





Figure 1 Type of cut

Table I Forms of Supply for Slydring®

Material	Ring Diameter (Inches)	Cut Strip for Diameter (Inches)
Turcite® T47/T51	.500 to 99	1 - 96
Zurcon® Z80	.500 to 20	3 - 96
Orkot® C320	.750 to 60	12 - 80
Orkot® C380	.750 to 60	-
Orkot® C932	.750 to 60	-
HiMod® HM061	.500 to 36	-
HiMod® HM803	.500 to 36	-
HiMod® HM852	.500 to 36	-



Table II Selection Criteria for Slydring®

Slydring®		Application			Mating surface	Standard	Installation	Material	
Type	Page	Field of Application							ISO
			Light	Medium	Heavy				
 Turcon® / Zurcon® Slydring®	8	Mobile hydraulics	●			Steel Steel, hardchromed Cast iron	Rings up to 100 inches diameter	Turcon® T47	
		Standard cylinders	●	●					
		Machine tools	●	●					
		Injection moulding machines	●	●		Mild steel Stainless steel Aluminium, alloys		Turcon® T51	
		Automotive industry	●	●					
		Pneumatics	●			Mild steel Stainless steel Aluminium, alloys		Turcon® T51	
		Water hydraulics	●	●					
		Dry application	●	●					
		Food stuff industry	●	●		Steel Mild steel Steel, hard chromed Stainless steel Aluminium, bronze Ceramic coating		Rings up to 100 inches diameter	Zurcon® Z80 UHMWPE
		Water hydraulics	●	●					
Dry application	●	●							
Pneumatics	●	●							
 HiMod® Slydring®	10	Mobile hydraulics	●	●	●	Steel Steel, hardchromed Cast iron	Rings up to 36 inches diameter	HiMod® HM803 PA/Glass fiber	
		Standard cylinders	●	●	●				
		Agricultural machinery	●	●	●				
		Injection moulding machines	●	●	●	Steel Steel, hardchromed Cast iron		HiMod® HM852 PA/Glass fiber + PTFE	
		Mobile hydraulics	●	●					
		Standard cylinders	●	●					
		Agricultural machinery	●	●					
		Injection moulding machines	●	●		Steel Steel, hardchromed Cast iron		HiMod® HM061 POM/Glass fiber	
Mobile hydraulics	●	●							
Standard cylinders	●	●							
Agricultural machinery	●	●							
 Orkot® Slydring®	12	Mobile hydraulics	●	●	●	Steel Steel, hardchromed Cast iron	Rings up to 30 inches diameter	Orkot® C320	
		Standard cylinders	●	●	●				
		Presses	●	●	●				
		Mobile hydraulics		●	●	Steel Steel, hardchromed Cast iron		Orkot® C380	
		Standard cylinders	●	●	●				
		Water hydraulics	●	●	●				
		Shipping and marine engineering	●	●	●				
		Presses	●	●	●	Steel Steel, hardchromed Cast iron		Orkot® C932	
		Mobile hydraulics		●	●				
Standard cylinders	●	●	●						
Presses	●	●	●						



Slydring® - Wear Ring

Slydring® has a tightly controlled thickness to maximize its load carrying capability and extend the life of the seals. A precision wall thickness tolerance of .002" is achieved on our standard product in this catalog. Our HiMod® Slydring® HM803 and HM852 are available with ultra-tight tolerance wall thickness of 0.124- 0.125 inches and loose tolerance of 0.122 - 0.125 inches. Wall thicknesses and sizes not mentioned in this catalog are available. Contact you local Trelleborg Sealing Solutions sales office for further information.

Table III Radial Clearance

Bore Diameter	min.	max.
.20 - .79	.20	.30
.80 - 3.99	.25	.40
4.00 - 9.99	.30	.60
10.00 - 19.99	.40	.80
20.00 - 39.99	.50	1.10
>40.00	.60	1.20

Table IV Surface Roughness

Parameter	Mating surface				Groove Surface
	Turcite® Materials	Zurcon® Materials	HiMod® Materials	Orkot® Materials	
R _{max.}	.63 - 4.00	1.00 - 4.00	1.00 - 4.00	1.00 - 4.0	< 16.0
R _Z DIN	.40 - 2.50	.63 - 2.50	.63 - 2.50	.63 - 2.50	< 10.0
R _a	.005 - .40	.10 - .40	.10 - .40	.10 - .40	< 2.50

Slydring® also allows foreign particles to be wiped away rather than being squeezed between the metal components. The slot 'Z1' allows fluid to pass across the ring thus preventing fluid pressure buildup which might cause extrusion of the guide ring. To ensure the ring cannot escape out of the groove it is recommended to observe the following radial gap sizes as maximum:

- .020 for .060 thickness
- .035 for .125 thickness

Important Note:

The above stated limits for pressure and speed are maximum values individually. Friction heat generated by the combination of pressure and speed may cause local heat buildup. Care should be taken not to apply high values for pressure and speed at the same time.



■ Design Instructions

Selection of Slydring®

An initial choice can be made for various applications by checking the Selection Criteria for Slydring® in Turcite®, Zurcon®, HiMod® or Orkot®, see Table I and the pages , , 10, and 12.

The values for the load on the Slydring® are valid for a load distribution as illustrated in Figure . The flexibility of the materials ensures a relatively constant specific load, irrespective of the size of the radial forces F, as with increasing radial loading, the guide surface subjected to the load increases also.

The radial forces which occur can vary within wide ranges and cannot always be calculated exactly in advance. For such cases, a safety factor of at least 2 is recommended when calculating (see calculation example).

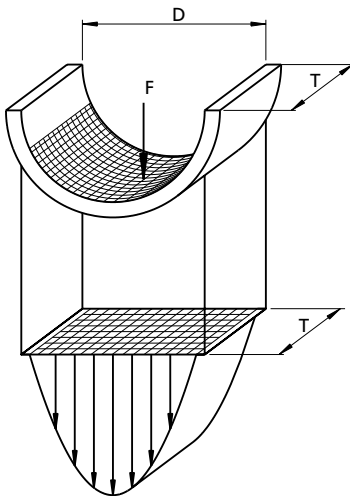

Figure 2 Load distribution

The large effective bearing area of non-metallic Slydring® gives low maximum contact pressure.

Dimensioning of Slydring®

The radial bearing pressure and the resulting elastic deflection are important parameters in the design of the Slydring®. The radial offset resulting from the dimensional tolerances, deflection and wear should always be less than the smallest gap to be sealed by the system. On request, we are willing to carry out dimensioning calculations for specific applications.

A rough estimate of the number and width of Slydring® required can be calculated using the following formula:

$$\text{Slydring}^{\circledR} \text{ width } T_{\text{total}} = \frac{F \times f}{d_N \times Pr}$$

where:

F = Maximum radial load [N]

f = Safety factor

d_N = Rod diameter [mm]

Pr = Radial Slydring® pressure [N/mm²]

Example:

d_N = 60 mm

F = 40.000 N

t = 40 °C

f = 2

Slydring® material Orkot® C 380

Pr_{per.} 100 N/mm²

$$T_{\text{total}} = \frac{40.000 \times 2}{60 \times 100} = 13.3 \text{ mm}$$

From Table , a groove with a width of 15 mm or 2 grooves with widths of 9.7 mm are selected. The installation of two strips is recommended as this gives a wider guide length.

Selected:

2 strips Series GR69 with a groove width L₂ = 9.7 mm

When calculating the width of Slydring® it is recommended to use a safety factor f=2.



Turcite® Slydring® - Wear Ring

■ Turcite® Slydring®

Description

Turcite® Slydring® is used as piston and rod guides due to their outstanding friction behaviour, stick-slip free running and good resistance to high temperatures and chemicals.

Design

Turcite® Slydring® is also available as cut-to-length strips or in bulk rolls. Please contact your local Trelleborg Sealing Solutions sales office for more information.

Advantages

- No stick-slip effect when starting for smooth operation even at very low speeds
- Minimum static and dynamic friction coefficient for low operating temperature and energy loss
- Suitable for non lubricating fluids depending on Turcite® material for optimum design flexibility
- High wear resistance ensures long service life
- Installation grooves according to ISO 10766
- Suitable for most hydraulic fluids in relation with the majority of modern hardware materials and surface finish depending on material selected.
- Suitable for new environmentally safe hydraulic fluids
- The embedding of foreign particles is enhanced
- Good damping effect, absorbs vibrations

Technical Data

The Turcite® Slydring® with angle cut is recommended for reciprocating movements

Velocity: Up to 10.8 ft/s

Temperature: -71°F to +302°F

Media: Mineral Oil based Hydraulic fluids, barely flammable hydraulic fluids, environmentally safe hydraulic fluids (biological degradable oils), water, air and others. Depending on the Turcite® material compatibility.

Clearance: The maximum permissible radial clearance s_{max} is depending on the actual sealing system.

Radial Slydring® pressure Pr: Max. 2,175 psi at 77°F
Max. 1,740 psi at 176°F
Max. 1,160 psi at 248°F

Materials

Standard Application:

- For hydraulic components with reciprocating movement in mineral oils or medium with good lubricating performance. Low friction, high resistance to wear, heat and chemicals:
Turcite® T47 (bronze filled)
Color: Turquoise
Material code: T47

Special Application:

- For lubricated and poor lubricated moving components: Water hydraulics and soft metal surfaces:
Turcite® T51 (carbon filled)
Color: Brown
Material code: T51
- For short stroke movements, non-lubricating fluids, water hydraulics, soft metal surfaces or pneumatic, applications requiring self-lubricating sealing materials:
Turcite® T59 (carbon fiber filled)
Color: Brown
Material code: T51

With the Turcite® materials it must be taken into account that the permissible surface pressure decreases with increasing temperatures. The load bearing ability for dynamic applications in practice is dependent primarily on the operating temperature. This should therefore generally not exceed 302°F (150°C).

**Table V Installation in Closed Grooves
Minimum Diameter for Turcite® Slydring**

	Ring Thickness	
	.063	.125
Axial Width	Minimum Ring Diameter	
.375	.875	1.000
.500	.875	1.000
.625	1.125	1.250
.750	1.125	1.500
1.000	1.500	1.500
1.250	1.620	2.000
1.500	2.000	2.000
1.750	2.000	2.500
2.000	2.000	2.500
2.500	2.000	2.750





■ Zurcon® Slydring®

Zurcon® Z80

Z80 is a UHMW-PE (ultra high molecular weight polyethylene) material which meets the requirements in FDA 21 CFR 177:1520 and is therefore recommended for use in foodstuff applications. The material is also preferred for use in water hydraulics and pneumatics due to excellent friction and wear properties.

Color: White

Material code: Z80

Advantages:

- Good lubrication and wear performance
- Self-lubricating
- Low friction value
- No water absorption
- In compliance with FDA
- Excellent resistance to chemicals
- High wear resistance.

Technical Data

Velocity, reciprocating: Max. 6.6 ft/s

Temperature: -76°F to +176°F

Radial Slydring®
pressure Pr: Max. 3,625 psi at 77°F
Max. 1,450 psi from 140°F
to 176°F



■ HiMod® Slydring® for Piston and Rod

Description

HiMod® Slydring® is made in special, modified thermoplastic material and can be used in hydraulic cylinders for medium to high loads. HiMod® HM803 and HiMod® HM852 are two of many custom blended materials from the **Hydro Components** family of premium nylon materials. Three different standard grades of material are available:

HiMod® HM061: A special glass fiber-reinforced poly-acetal

HiMod® HM803: A special glass fiber-reinforced heat-stabilized polyamid

HiMod® HM852: A special glass fiber-reinforced heat-stabilized polyamid with PTFE

Materials

HiMod® HM061

HiMod® HM061 is a polyacetal (POM) based material with glass fibers.

Color: Tan

Material code: HM061

Advantages:

- Favorable price/performance ratio
- High compressive strength
- Easy installation on pistons and glands (gland bore < 1.50 inches)
- High wear resistance
- Water absorption 0.2 %
- High stiffness

Technical Data

Velocity, reciprocating: Max. 2.65 ft/s

Temperature: -40°F to +230°F

Radial Slydring®
pressure Pr: Max. 5,800 psi at 77°F
Max. 3,625 psi >140°F



■ HiMod® Slydring® for Piston and Rod

HiMod® Slydring® HM803

Hydro-Components proprietary heat-stabilized polyamid material with special glass fibers for improved bearing characteristics and proven performance
 Color: Dark Gray
 Material code: HM803

Advantages:

- Excellent price/performance ratio
- High compressive strength even at high temperatures
- High wear resistance
- Easy installation on pistons and glands (Use .060 wall for bores under 1.50 inches)
- Low Friction

Technical Data

Velocity, reciprocating: Max. 3.3 ft/s
 Temperature: -40°F to +275°F
 Radial Slydring® pressure Pr: Max. 10,877 psi at 140°F
 Max. 5,800 psi > 140°C
 Water Absorption: < 1%

HiMod® Slydring® HM852

Hydro-Components proprietary heat-stabilized polyamid material with special glass fibers plus PTFE lubricant for applications with marginal lubricity
 Color: Dark Gray
 Material code: HM852

Advantages:

- Excellent price/performance ratio
- High compressive strength even at high temperatures
- High wear resistance
- Easy installation on pistons and glands (Use .060 wall for bores under 1.50 inches)
- Lower friction
- For operation under poor lubrication.

Technical Data

Velocity, reciprocating: Max. 3.3 ft/s
 Temperature: -40°F to +275°F
 Radial Slydring® pressure Pr: Max. 10,877 psi at 140°F
 Max. 5,800 psi > 140°F

**Table VI Installation in Closed Grooves
 Minimum Diameter for HiMod® Slydring**

	Ring Thickness	
	.063	.125
Axial Width	Minimum Ring Diameter	
.375	.875	1.000
.500	.875	1.000
.625	1.125	1.250
.750	1.125	1.500
1.000	1.500	1.500
1.250	1.620	2.000
1.500	2.369	2.000
1.750	2.870	2.500
2.000	3.875	2.500
2.500	N/A	2.750



■ Orkot® Slydring® for Piston and Rod

Description

Orkot® Slydring® of fabric-reinforced composite materials is used in hydraulic cylinders exposed to high loads that can occur, e.g. in mobile hydraulics and presses. The high compressive strength, good sliding behavior and the exceptional wear resistant properties ensure a long service life.

Slydring® of Orkot® fabric composite materials is produced as standard from tubular material. It is manufactured with an angle cut and already has the necessary gap Z1

For large diameters > 12 inches rings can be cut from Orkot® C320, C380 strip material. This offers economical solutions for non-standard diameters or when quantities are limited.

Materials

Orkot® C320

Orkot® C320 is a fabric composite material made of a thermosetting polymer, reinforced by a fine plastic mesh and lubricant additives impregnated throughout the material. It has a very high resistance to wear, good dry-running properties and dampens vibrations.

Color: dark gray

Material code: C320

Orkot® C380

Orkot® C380 is the standard material, this turquoise colored composite is a further development of the proven C320. It is most versatile; It is suitable for all commonly used hydraulic fluids such as mineral or synthetic oils, as well as water based fluids. It is an excellent electrical insulator and features enhanced sliding properties in various media.

Color: Turquoise

Material code: C380

Orkot® C932

Orkot® C932 is a composite of phenolic resin impregnated into a fine cotton fabric. The material stiffness is higher than C380 I C320. The use in water-based fluids is not recommended.

Color: yellow-brown

Material code: C932

Technical Data

Velocity: Up to 3.3 ft/s, with reciprocating movements

Temperature: - 105°F to + 250°F

Pr under dynamic conditions (C380, C320, C932): max. 14,500 psi at 77°F max. 7,250 psi >140°F

Ultimate compressive strength (C380, C320): max. > 43,500 psi (C932): max. 37,709 psi

Advantages

- Dimensionally stable and vibration absorbing
- Even distribution of high radial forces
- Good sliding and dry running properties
- High wear resistance
- Good wiping effect
- Long service life.

Table VII Installation in Closed Grooves Minimum Diameter for Orkot® Slydring

	Ring Thickness	
	.063	.125
Axial Width	Minimum Ring Diameter	
.375	.500	.500
.500	.500	.500
.625	.750	.750
.750	1.000	1.000
1.000	1.000	1.000
1.250	1.750	1.750
1.500	1.750	1.750
1.750	2.000	2.000
2.000	2.000	2.000
2.500	3.000	3.000





■ Installation and Part Numbers for Piston

Installation Recommendation – Piston (Inch Series)

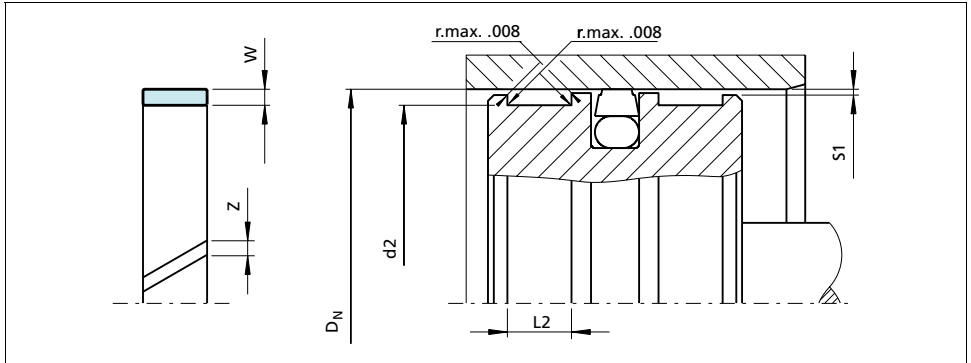

Figure 3 Installation drawing

Table VIII Installation Recommendation

TSS Series No.	Bore Diameter	Groove Diameter	Groove Width	Thickness
	D_N H9	d_2 f8/h9	L_2 +.010	W (max)
GP0B	1.000 - 4.000	D_N - .126	.385	.063
GP0C	1.000 - 4.000	D_N - .126	.510	.063
GP2B	1.000 - 4.000	D_N - .250	.385	.125
GP2C	1.250 - 10.000	D_N - .250	.510	.125
GP2D	1.500 - 10.000	D_N - .250	.635	.125
GP2E	2.000 - 12.000	D_N - .250	.760	.125
GP2F	2.500 - 16.000	D_N - .250	1.010	.125
GP2G	3.000 - 20.000	D_N - .250	1.260	.125
GP2H	4.000 - 20.000	D_N - .250	1.510	.125
GP2J	6.000 - 20.000	D_N - .250	1.760	.125
GP2K	8.000 - 20.000	D_N - .250	2.010	.125
GP2L	10.000 - 20.000	D_N - .250	2.510	.125

Notes:

- (1) Tolerances used are per ISO-286 system of limits and fits.
- (2) **Bold** Print indicates preferred series



Slydring® - Wear Ring

Ordering Example

Slydring® for Bore diameter $D_N = 3.250$ inches
 Series GP2C from Table VIII
 Groove width: .510 inches ring thickness .125 inches

Material: Orkot® C380
 Standard With angle cut

Design: With angle cut and teardrop structure
 Design code: 0

TSS Article No.	GP2C	03250	-	C380
TSS Series No.				
Bore Diameter x 1000				
Quality Index (Standard)				
Material code				

TSS Part No.: GP6901000 (from Table IX)

Table IX Slydring® for Pistons

Dimensions				TSS Part No.
Bore Diameter	Groove Diameter	Groove Width	Thickness	
$D_N H9$	$d_2 h9$	$L_2 +0.2$	W	
1.250	1.000	.510	.125	GP2C01250
1.313	1.063	.510	.125	GP2C01313
1.375	1.125	.510	.125	GP2C01375
1.438	1.188	.510	.125	GP2C01438
1.500	1.250	.510	.125	GP2C01500
1.563	1.313	.510	.125	GP2C01563
1.625	1.375	.510	.125	GP2C01625
1.688	1.438	.510	.125	GP2C01688
1.750	1.500	.510	.125	GP2C01750
1.813	1.563	.510	.125	GP2C01813
1.875	1.625	.510	.125	GP2C01875
1.938	1.688	.510	.125	GP2C01938
2.000	1.750	.510	.125	GP2C02000
2.125	1.875	.510	.125	GP2C02125
2.250	2.000	.510	.125	GP2C02250
2.375	2.125	.510	.125	GP2C02375
2.500	2.250	.510	.125	GP2C02500
2.625	2.375	.510	.125	GP2C02625
2.750	2.500	.510	.125	GP2C02750
2.875	2.625	.510	.125	GP2C02875
3.000	2.750	.510	.125	GP2C03000
3.125	2.875	.510	.125	GP2C03125
3.250	3.000	.510	.125	GP2C03250
3.375	3.125	.510	.125	GP2C03375
3.500	3.250	.510	.125	GP2C03500
3.625	3.375	.510	.125	GP2C03625

The sizes listed in **bold** font are preferred sizes (more likely to be available for immediate shipment).



Dimensions				TSS Part No.
Bore Diameter	Groove Diameter	Groove Width	Thickness	
D_N H9	d_2 h9	$L_2 +0.2$	W	
3.750	3.500	.510	.125	GP2C03750
3.875	3.625	.510	.125	GP2C03875
4.000	3.750	.510	.125	GP2C04000
4.125	3.875	.510	.125	GP2C04125
4.250	4.000	.510	.125	GP2C04250
4.375	4.125	.510	.125	GP2C04375
4.500	4.250	.510	.125	GP2C04500
4.625	4.375	.510	.125	GP2C04625
4.750	4.500	.510	.125	GP2C04750
4.875	4.625	.510	.125	GP2C04875
5.000	4.750	.510	.125	GP2C05000
5.125	4.875	.510	.125	GP2C05125
5.250	5.000	.510	.125	GP2C05250
5.375	5.125	.510	.125	GP2C05375
5.500	5.250	.510	.125	GP2C05500
5.625	5.375	.510	.125	GP2C05625
5.750	5.500	.510	.125	GP2C05750
5.875	5.625	.510	.125	GP2C05875
6.000	5.750	.510	.125	GP2C06000
6.250	6.000	.510	.125	GP2C06250
6.500	6.250	.510	.125	GP2C06500
6.750	6.500	.510	.125	GP2C06750
7.000	6.750	.510	.125	GP2C07000
7.250	7.000	.510	.125	GP2C07250
7.500	7.250	.510	.125	GP2C07500
7.750	7.500	.510	.125	GP2C07750
8.000	7.750	.510	.125	GP2C08000
8.250	8.000	.510	.125	GP2C08250
8.500	8.250	.510	.125	GP2C08500
8.750	8.500	.510	.125	GP2C08750
9.000	8.750	.510	.125	GP2C09000
9.250	9.000	.510	.125	GP2C09250
9.500	9.250	.510	.125	GP2C09500
9.750	9.500	.510	.125	GP2C09750
10.000	9.750	.510	.125	GP2C10000
10.500	10.250	.510	.125	GP2C10500

The sizes listed in **bold** font are preferred sizes (more likely to be available for immediate shipment).



Slydring® - Wear Ring

Dimensions				TSS Part No.
Bore Diameter	Groove Diameter	Groove Width	Thickness	
D_N H9	d_2 h9	L_2 +0.2	W	
11.000	10.750	.510	.125	GP2C11000
11.500	11.250	.510	.125	GP2C11500
12.000	11.750	.510	.125	GP2C12000
4.000	3.750	.760	.125	GP2E04000
4.125	3.875	.760	.125	GP2E04125
4.250	4.000	.760	.125	GP2E04250
4.375	4.125	.760	.125	GP2E04375
4.500	4.250	.760	.125	GP2E04500
4.625	4.375	.760	.125	GP2E04625
4.750	4.500	.760	.125	GP2E04750
4.875	4.625	.760	.125	GP2E04875
5.000	4.750	.760	.125	GP2E05000
5.125	4.875	.760	.125	GP2E05125
5.250	5.000	.760	.125	GP2E05250
5.375	5.125	.760	.125	GP2E05375
5.500	5.250	.760	.125	GP2E05500
5.625	5.375	.760	.125	GP2E05625
5.750	5.500	.760	.125	GP2E05750
5.875	5.625	.760	.125	GP2E05875
6.000	5.750	.760	.125	GP2E06000
6.250	6.000	.760	.125	GP2E06250
6.500	6.250	.760	.125	GP2E06500
6.750	6.500	.760	.125	GP2E06750
7.000	6.750	.760	.125	GP2E07000
7.250	7.000	.760	.125	GP2E07250
7.500	7.250	.760	.125	GP2E07500
7.750	7.500	.760	.125	GP2E07750
8.000	7.750	.760	.125	GP2E08000
8.250	8.000	.760	.125	GP2E08250
8.500	8.250	.760	.125	GP2E08500
8.750	8.500	.760	.125	GP2E08750
9.000	8.750	.760	.125	GP2E09000
9.250	9.000	.760	.125	GP2E09250
9.500	9.250	.760	.125	GP2E09500
9.750	9.500	.760	.125	GP2E09750

The sizes listed in **bold** font are preferred sizes (more likely to be available for immediate shipment).



Dimensions				TSS Part No.
Bore Diameter	Groove Diameter	Groove Width	Thickness	
D _N H9	d ₂ h9	L ₂ +0.2	W	
10.000	9.750	.760	.125	GP2E10000
10.500	10.250	.760	.125	GP2E10500
11.000	10.750	.760	.125	GP2E11000
11.500	11.250	.760	.125	GP2E11500
12.000	11.750	.760	.125	GP2E12000
12.500	12.250	.760	.125	GP2E12500
13.000	12.750	.760	.125	GP2E13000
13.500	13.250	.760	.125	GP2E13500
14.000	13.750	.760	.125	GP2E14000
14.500	14.250	.760	.125	GP2E14500
15.000	14.750	.760	.125	GP2E15000
15.500	15.250	.760	.125	GP2E15500
16.000	15.750	.760	.125	GP2E16000
16.500	16.250	.760	.125	GP2E16500
17.000	16.750	.760	.125	GP2E17000
17.500	17.250	.760	.125	GP2E17500
18.000	17.750	.760	.125	GP2E18000
18.500	18.250	.760	.125	GP2E18500
19.000	18.750	.760	.125	GP2E19000
19.500	19.250	.760	.125	GP2E19500
20.000	19.750	.760	.125	GP2E20000
6.000	5.750	1.010	.125	GP2F06000
6.250	6.000	1.010	.125	GP2F06250
6.500	6.250	1.010	.125	GP2F06500
6.750	6.500	1.010	.125	GP2F06750
7.000	6.750	1.010	.125	GP2F07000
7.250	7.000	1.010	.125	GP2F07250
7.500	7.250	1.010	.125	GP2F07500
7.750	7.500	1.010	.125	GP2F07750
8.000	7.750	1.010	.125	GP2F08000
8.250	8.000	1.010	.125	GP2F08250
8.500	8.250	1.010	.125	GP2F08500
8.750	8.500	1.010	.125	GP2F08750
9.000	8.750	1.010	.125	GP2F09000
9.250	9.000	1.010	.125	GP2F09250

The sizes listed in **bold** font are preferred sizes (more likely to be available for immediate shipment).



Slydring® - Wear Ring

Dimensions				TSS Part No.
Bore Diameter	Groove Diameter	Groove Width	Thickness	
D_N H9	d_2 h9	L_2 +0.2	W	
9.500	9.250	1.010	.125	GP2F09500
9.750	9.500	1.010	.125	GP2F09750
10.000	9.750	1.010	.125	GP2F10000
10.500	10.250	1.010	.125	GP2F10500
11.000	10.750	1.010	.125	GP2F11000
11.500	11.250	1.010	.125	GP2F11500
12.000	11.750	1.010	.125	GP2F12000
12.500	12.250	1.010	.125	GP2F12500
13.000	12.750	1.010	.125	GP2F13000
13.500	13.250	1.010	.125	GP2F13500
14.000	13.750	1.010	.125	GP2F14000
14.500	14.250	1.010	.125	GP2F14500
15.000	14.750	1.010	.125	GP2F15000
15.500	15.250	1.010	.125	GP2F15500
16.000	15.750	1.010	.125	GP2F16000
16.500	16.250	1.010	.125	GP2F16500
17.000	16.750	1.010	.125	GP2F17000
17.500	17.250	1.010	.125	GP2F17500
18.000	17.750	1.010	.125	GP2F18000
18.500	18.250	1.010	.125	GP2F18500
19.000	18.750	1.010	.125	GP2F19000
19.500	19.250	1.010	.125	GP2F19500
20.000	19.750	1.010	.125	GP2F20000

The sizes listed in **bold** font are preferred sizes (more likely to be available for immediate shipment).



■ Installation and Part Numbers for Rod

Installation Recommendation - Rod (Inch Series)

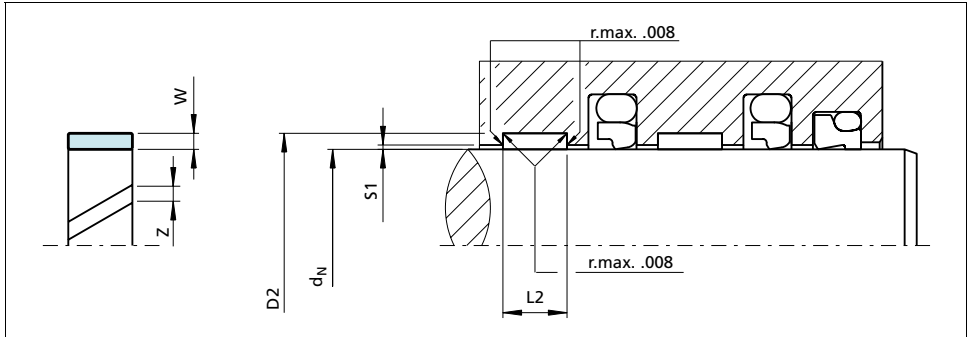

Figure 4 Installation drawing

Table X Installation Recommendation

TSS Series No.	Rod Diameter	Groove Diameter	Groove Width	Thickness
	d_N f8/h9	D_2 H9	L_2 +.010	W (max)
GR0B	.750 - 2.500	d_N + .126	.385	.063
GR0C	1.250 - 4.000	d_N + .126	.510	.063
GR2B	1.250 - 4.000	d_N + .250	.385	.125
GR2C	1.250 - 8.000	d_N + .250	.510	.125
GR2D	1.500 - 10.000	d_N + .250	.635	.125
GR2E	2.500 - 12.000	d_N + .250	.760	.125
GR2F	3.000 - 16.000	d_N + .250	1.010	.125
GR2G	3.500 - 20.000	d_N + .250	1.260	.125
GR2H	4.000 - 20.000	d_N + .250	1.510	.125
GR2J	6.000 - 20.000	d_N + .250	1.760	.125
GR2K	8.000 - 20.000	d_N + .250	2.010	.125
GR2L	10.000 - 20.000	d_N + .250	2.510	.125

Notes:

- (1) Tolerances used are per ISO-286 system of limits and fits.
- (2) **Bold** Print indicates preferred series



Slydring® - Wear Ring

Ordering Example

Slydring® for Rod diameter dN = 3.250 inches
 Series GR2C from Table X
 Groove width: .510 inches ring thickness .125 inches

Material: Turcite® T47

Standard With angle cut
 design:

TSS Part No.: GR2C03250 (from Table XI)

TSS Article No.	GR2C	03250	-	T47
TSS Series No.				
Rod Diameter x 1000				
Quality Index (Standard)				
Material code				

Table XI Slydring® for Rods

Dimensions				TSS Part No.
Rod Diameter	Groove Diameter	Groove Width	Thickness	
d _N f8/h9	D ₂ H9	L ₂ +.010	W (Max)	
.750	.875	.510	.063	GR0C00750
.875	1.000	.510	.063	GR0C00875
1.000	1.125	.510	.063	GR0C01000
1.125	1.250	.510	.063	GR0C01125
1.250	1.375	.510	.063	GR0C01250
1.375	1.500	.510	.063	GR0C01375
1.500	1.625	.510	.063	GR0C01500
1.625	1.750	.510	.063	GR0C01625
1.750	1.875	.510	.063	GR0C01750
1.875	2.000	.510	.063	GR0C01875
2.000	2.125	.510	.063	GR0C02000
1.250	1.500	.510	.125	GR2C01250
1.313	1.563	.510	.125	GR2C01313
1.375	1.625	.510	.125	GR2C01375
1.438	1.688	.510	.125	GR2C01438
1.500	1.750	.510	.125	GR2C01500
1.563	1.813	.510	.125	GR2C01563
1.625	1.875	.510	.125	GR2C01625
1.688	1.938	.510	.125	GR2C01688
1.750	2.000	.510	.125	GR2C01750
1.813	2.063	.510	.125	GR2C01813
1.875	2.125	.510	.125	GR2C01875
1.938	2.188	.510	.125	GR2C01938
2.000	2.250	.510	.125	GR2C02000
2.125	2.375	.510	.125	GR2C02125
2.250	2.500	.510	.125	GR2C02250

The sizes listed in **bold** font are preferred sizes (more likely to be available for immediate shipment).



Dimensions				TSS Part No.
Rod Diameter	Groove Diameter	Groove Width	Thickness	
d_N f8/h9	D_2 H9	L_2 +.010	W (Max)	
2.375	2.625	.510	.125	GR2C02375
2.500	2.750	.510	.125	GR2C02500
2.626	2.876	.510	.125	GR2C02626
2.750	3.000	.510	.125	GR2C02750
2.875	3.125	.510	.125	GR2C02875
3.000	3.250	.510	.125	GR2C03000
3.125	3.375	.510	.125	GR2C03125
3.250	3.500	.510	.125	GR2C03250
3.375	3.625	.510	.125	GR2C03375
3.500	3.750	.510	.125	GR2C03500
3.625	3.875	.510	.125	GR2C03625
3.750	4.000	.510	.125	GR2C03750
3.875	4.125	.510	.125	GR2C03875
4.000	4.250	.510	.125	GR2C04000
4.125	4.375	.510	.125	GR2C04125
4.250	4.500	.510	.125	GR2C04250
4.375	4.625	.510	.125	GR2C04375
4.500	4.750	.510	.125	GR2C04500
4.625	4.875	.510	.125	GR2C04625
4.750	5.000	.510	.125	GR2C04750
4.875	5.125	.510	.125	GR2C04875
5.000	5.250	.510	.125	GR2C05000
5.125	5.375	.510	.125	GR2C05125
5.250	5.500	.510	.125	GR2C05250
5.375	5.625	.510	.125	GR2C05375
5.500	5.750	.510	.125	GR2C05500
5.625	5.875	.510	.125	GR2C05625
5.750	6.000	.510	.125	GR2C05750
5.875	6.125	.510	.125	GR2C05875
6.000	6.250	.510	.125	GR2C06000
6.250	6.500	.510	.125	GR2C06250
6.500	6.750	.510	.125	GR2C06500
6.750	7.000	.510	.125	GR2C06750
7.000	7.250	.510	.125	GR2C07000
7.250	7.500	.510	.125	GR2C07250
7.500	7.750	.510	.125	GR2C07500

The sizes listed in **bold** font are preferred sizes (more likely to be available for immediate shipment).



Slydring® - Wear Ring

Dimensions				TSS Part No.
Rod Diameter	Groove Diameter	Groove Width	Thickness	
d_N f8/h9	D_2 H9	L_2 +.010	W (Max)	
7.750	8.000	.510	.125	GR2C07750
8.000	8.250	.510	.125	GR2C08000
8.250	8.500	.510	.125	GR2C08250
8.500	8.750	.510	.125	GR2C08500
8.750	9.000	.510	.125	GR2C08750
9.000	9.250	.510	.125	GR2C09000
9.250	9.500	.510	.125	GR2C09250
9.500	9.750	.510	.125	GR2C09500
9.750	10.000	.510	.125	GR2C09750
10.000	10.250	.510	.125	GR2C10000
10.500	10.750	.510	.125	GR2C10500
11.000	11.250	.510	.125	GR2C11000
11.500	11.750	.510	.125	GR2C11500
12.000	12.250	.510	.125	GR2C12000
4.000	4.250	.760	.125	GR2E04000
4.125	4.375	.760	.125	GR2E04125
4.250	4.500	.760	.125	GR2E04250
4.375	4.625	.760	.125	GR2E04375
4.500	4.750	.760	.125	GR2E04500
4.625	4.875	.760	.125	GR2E04625
4.750	5.000	.760	.125	GR2E04750
4.875	5.125	.760	.125	GR2E04875
5.000	5.250	.760	.125	GR2E05000
5.125	5.375	.760	.125	GR2E05125
5.250	5.500	.760	.125	GR2E05250
5.375	5.625	.760	.125	GR2E05375
5.500	5.750	.760	.125	GR2E05500
5.625	5.875	.760	.125	GR2E05625
5.750	6.000	.760	.125	GR2E05750
5.875	6.125	.760	.125	GR2E05875
6.000	6.250	.760	.125	GR2E06000
6.250	6.500	.760	.125	GR2E06250
6.500	6.750	.760	.125	GR2E06500
6.750	7.000	.760	.125	GR2E06750
7.000	7.250	.760	.125	GR2E07000

The sizes listed in **bold** font are preferred sizes (more likely to be available for immediate shipment).



Dimensions				TSS Part No.
Rod Diameter	Groove Diameter	Groove Width	Thickness	
d_N f8/h9	D_2 H9	L_2 +.010	W (Max)	
7.250	7.500	.760	.125	GR2E07250
7.500	7.750	.760	.125	GR2E07500
7.750	8.000	.760	.125	GR2E07750
8.000	8.250	.760	.125	GR2E08000
8.250	8.500	.760	.125	GR2E08250
8.500	8.750	.760	.125	GR2E08500
8.750	9.000	.760	.125	GR2E08750
9.000	9.250	.760	.125	GR2E09000
9.250	9.500	.760	.125	GR2E09250
9.500	9.750	.760	.125	GR2E09500
9.750	10.000	.760	.125	GR2E09750
10.000	10.250	.760	.125	GR2E10000
10.500	10.750	.760	.125	GR2E10500
11.000	11.250	.760	.125	GR2E11000
11.500	11.750	.760	.125	GR2E11500
12.000	12.250	.760	.125	GR2E12000
12.500	12.750	.760	.125	GR2E12500
13.000	13.250	.760	.125	GR2E13000
13.500	13.750	.760	.125	GR2E13500
14.000	14.250	.760	.125	GR2E14000
14.500	14.750	.760	.125	GR2E14500
15.000	15.250	.760	.125	GR2E15000
15.500	15.750	.760	.125	GR2E15500
16.000	16.250	.760	.125	GR2E16000
16.500	16.750	.760	.125	GR2E16500
17.000	17.250	.760	.125	GR2E17000
17.500	17.750	.760	.125	GR2E17500
18.000	18.250	.760	.125	GR2E18000
18.500	18.750	.760	.125	GR2E18500
19.000	19.250	.760	.125	GR2E19000
19.500	19.750	.760	.125	GR2E19500
20.000	20.250	.760	.125	GR2E20000
6.000	6.250	1.010	.125	GR2F06000
6.250	6.500	1.010	.125	GR2F06250
6.500	6.750	1.010	.125	GR2F06500

The sizes listed in **bold** font are preferred sizes (more likely to be available for immediate shipment).



Slydring® - Wear Ring

Dimensions				TSS Part No.
Rod Diameter	Groove Diameter	Groove Width	Thickness	
d_N f8/h9	D_2 H9	L_2 +.010	W (Max)	
6.750	7.000	1.010	.125	GR2F06750
7.000	7.250	1.010	.125	GR2F07000
7.250	7.500	1.010	.125	GR2F07250
7.500	7.750	1.010	.125	GR2F07500
7.750	8.000	1.010	.125	GR2F07750
8.000	8.250	1.010	.125	GR2F08000
8.250	8.500	1.010	.125	GR2F08250
8.500	8.750	1.010	.125	GR2F08500
8.750	9.000	1.010	.125	GR2F08750
9.000	9.250	1.010	.125	GR2F09000
9.250	9.500	1.010	.125	GR2F09250
9.500	9.750	1.010	.125	GR2F09500
9.750	10.000	1.010	.125	GR2F09750
10.000	10.250	1.010	.125	GR2F10000
10.500	10.750	1.010	.125	GR2F10500
11.000	11.250	1.010	.125	GR2F11000
11.500	11.750	1.010	.125	GR2F11500
12.000	12.250	1.010	.125	GR2F12000
12.500	12.750	1.010	.125	GR2F12500
13.000	13.250	1.010	.125	GR2F13000
13.500	13.750	1.010	.125	GR2F13500
14.000	14.250	1.010	.125	GR2F14000
14.500	14.750	1.010	.125	GR2F14500
15.000	15.250	1.010	.125	GR2F15000
15.500	15.750	1.010	.125	GR2F15500
16.000	16.250	1.010	.125	GR2F16000
16.500	16.750	1.010	.125	GR2F16500
17.000	17.250	1.010	.125	GR2F17000
17.500	17.750	1.010	.125	GR2F17500
18.000	18.250	1.010	.125	GR2F18000
18.500	18.750	1.010	.125	GR2F18500
19.000	19.250	1.010	.125	GR2F19000
19.500	19.750	1.010	.125	GR2F19500
20.000	20.250	1.010	.125	GR2F20000

The sizes listed in **bold** font are preferred sizes (more likely to be available for immediate shipment).

DUALSEAL



- Radial sealing -
- For O-Ring grooves -
- Material Zurcon[®] -





■ Description

In current hydraulic cylinder design, O-Ring or O-Ring/Back-up Ring combinations are mainly used as static seals. However, this sealing solution hides the risk that during assembly the O-Ring may become twisted and that the position of the Back-up Ring is not optimal. This solution also exhibits weaknesses with regard to pressure pulsation and the ingress of dirt.

The Dualseal as a single component static hydraulic seal offers a good alternative in such cases.

Advantages

Compared with the O-Ring / Back-up Ring combination, the Dualseal offers the following advantages:

- High resistance to twisting
- Easy assembly
- Long service life
- High extrusion resistance

Table I Surface finish

Type of load	Surface	Rt μm	Rz μm	Ra μm
Radial-static	Mating surface Groove surface (groove diameter, groove flanks)	≤ 10.0 ≤ 16.0	≤ 6.3	≤ 1.6 ≤ 3.2

Lead-in chamfers

Groove depth < .12 inches (3 mm) \Rightarrow .12 inches x 15° (3 mm x 15°)

Groove depth > .12 inches (3 mm) \Rightarrow .20 inches x 15° (5 mm x 15°)

Preferred sealing gap

Bore H8

Gland g6

Due to the high extrusion resistance of the seal a radial sealing gap (S) of .008 inches (0.2 mm) can be realised.

In case of low temperature applications deviations of the gland to the bore and rod should be avoided.

Technical data

Operating pressure: Max. 7,500 psi (Max. 50 MPa)
 Operating temperature: -31 °F to +230 °F
 (-35 °C to +110 °C)

Important Note:

The application limits for pressure and temperature given in this catalogue are maximum values. During practical applications it should be remembered that due to the interaction of operating parameters the maximum values must be set correspondingly lower.

Material

Standard material: Zurcon® Z20 polyurethane 93 shore A, turquoise. Suitable for all HL and HLP hydraulic fluids.

Applications

The Dualseal allows general use in hydraulic cylinders:

- Fork lifts
- Mobile hydraulics
- Industrial hydraulics
- Machine tools
- Injection molding machines
- Hydraulic presses
- Cartridge valves

Dualseal performs leak-free and is highly extrusion resistant under the following test conditions:

	High pressure test	Pressure pulsation test
Pressure p	6,000/7,800 psi (40/52 MPa)	4,500 psi (30 MPa)
Temperature T	212°F / 176°F (100°C / 80°C)	140°F (60°C (max. tank temperature))
Medium	Hydraulic oil HLP 46	Hydraulic oil HLP 46
Test duration	72 h	500,000 Pressure pulsations



■ Installation Recommendation (Inch Series)

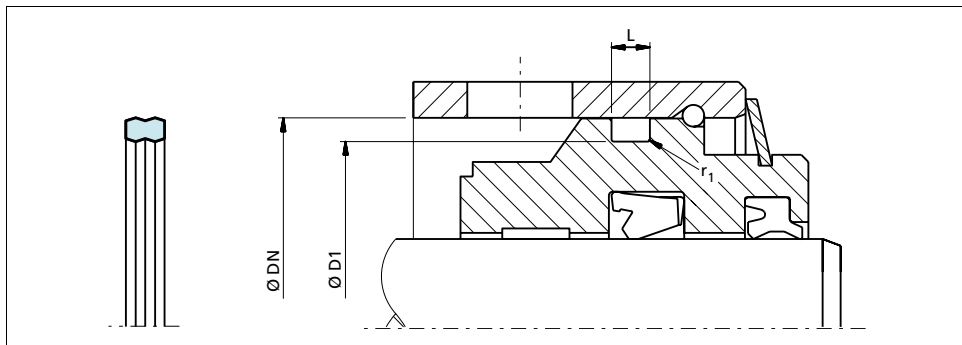

Figure 1 Installation drawing

Table II Installation dimensions / TSS Part No.

ASTM A5568 Size	Bore Diam.	Groove Diam.	Groove Width (L)	Radius	TSS Part No.
	DN H9	D1 H9	L +.008	r₁ +.008	
117	1.000	.838	.140	.012	DUB001000-Z20
121	1.250	1.088	.140	.012	DUB001250-Z20
125	1.500	1.338	.140	.012	DUB001500-Z20
129	1.750	1.588	.140	.012	DUB001750-Z20
133	2.000	1.838	.140	.012	DUB002000-Z20
137	2.250	2.088	.140	.012	DUB002250-Z20
141	2.500	2.338	.140	.002	DUB002500-Z20
232	3.000	2.778	.187	.012	DUC003000-Z20
234	3.250	3.028	.187	.012	DUC003250-Z20
236	3.500	3.278	.187	.012	DUC003500-Z20
238	3.750	3.528	.187	.012	DUC003750-Z20
240	4.000	3.778	.187	.012	DUC004000-Z20
242	4.250	4.028	.187	.012	DUC004250-Z20
244	4.500	4.278	.187	.012	DUC004500-Z20
246	4.750	4.528	.187	.012	DUC004750-Z20
248	5.000	4.778	.187	.012	DUC005000-Z20
250	5.250	5.028	.187	.012	DUC005250-Z20
354	5.500	5.160	.281	.012	DUD005500-Z20
358	6.000	5.660	.281	.012	DUD006000-Z20
117	1.000	.838	.171	.012	DUB101000-Z20
121	1.250	1.088	.171	.012	DUB101250-Z20

The sizes listed in **bold** font are preferred sizes (more likely to be available for immediate shipment).



ASTM AS568 Size	Bore Diam.	Groove Diam.	Groove Width (L)	Radius	TSS Part No.
	DN H9	D1 H9	L +.008	r₁ +.008	
125	1.500	1.338	.171	.012	DUB101500-Z20
129	1.750	1.588	.171	.012	DUB101750-Z20
133	2.000	1.838	.171	.012	DUB102000-Z20
137	2.250	2.088	.171	.012	DUB102250-Z20
141	2.500	2.338	.171	.012	DUB102500-Z20
232	3.000	2.778	.208	.012	DUC103000-Z20
234	3.250	3.028	.208	.012	DUC103250-Z20
236	3.500	3.278	.208	.012	DUC103500-Z20
238	3.750	3.528	.208	.012	DUC103750-Z20
240	4.000	3.778	.208	.012	DUC104000-Z20
242	4.250	4.028	.208	.012	DUC104250-Z20
244	4.500	4.278	.208	.012	DUC104500-Z20
246	4.750	4.528	.208	.012	DUC104750-Z20
248	5.000	4.778	.208	.012	DUC105000-Z20
250	5.250	5.028	.208	.012	DUC105250-Z20
354	5.500	5.160	.311	.012	DUD105500-Z20
358	6.000	5.660	.311	.012	DUD106000-Z20

The sizes listed in **bold** font are preferred sizes (more likely to be available for immediate shipment).

LOCAL CONTACTS

EUROPE

Austria – Vienna (Slovenia)

+43 (0) 1 406 47 33

Belgium – Dion-Valmont (Luxembourg)

+32 (0) 10 22 57 50

Bulgaria – Sofia

(Azerbaijan, Belarus, Greece, Romania, Ukraine)

+359 (0) 2 969 95 99

Croatia – Zagreb (Albania, Bosnia and Herzegovina,

Macedonia, Serbia, Montenegro)

+385 (0) 1 24 56 387

Czech Republic – Rakovník (Slovakia)

+420 313 529 111

Denmark – Copenhagen

+45 48 22 80 80

Finland – Vantaa (Estonia, Latvia)

+358 (0) 207 12 13 50

France – Maisons-Laffitte

+33 (0) 1 30 86 56 00

Germany – Stuttgart

+49 (0) 711 7864 0

Hungary – Budaörs

+36 (06) 23 50 21 21

Italy – Livorno

+39 0586 22 6111

The Netherlands – Rotterdam

+31 (0) 10 29 22 111

Norway – Oslo

+47 22 64 60 80

Poland – Warsaw (Lithuania)

+48 (0) 22 863 30 11

Russia – Moscow

+7 495 627 57 22

Spain – Madrid (Portugal)

+34 (0) 91 71057 30

Sweden – Jönköping

+46 (0) 36 34 15 00

Switzerland – Crissier

+41 (0) 21 631 41 11

Turkey – Istanbul

+90 216 569 73 00

United Kingdom – Solihull (Eire, South Africa)

+44 (0) 121 744 1221

Aerospace Hub Europe, North

(UK and Nordic Countries)

+44 (0) 121 744 1221

Aerospace Hub Europe, South & West

(Continental Europe and Middle East)

+33 (0) 1 30 86 56 00

Automotive Hub Europe

+49 (0) 711 7864 0

AMERICAS

Americas Regional

+1 260 749 9631

Brazil – São José dos Campos

+55 12 3932 7600

Canada Central – Etobicoke, ON

+1 416 213 9444

Canada East – Montreal, QC

+1 514 284 1114

Canada West – Langley, BC

+1 604 539 0098

Mexico – Mexico City

+52 55 57 19 50 05

USA, Great Lakes – Fort Wayne, IN

+1 260 482 4050

USA, East – Mt. Juliet, TN

+1 615 800 8340

USA, Midwest – Schaumburg, IL

+1 630 539 5500

USA, Northern California – Fresno, CA

+1 559 449 6070

USA, Northwest – Portland, OR

+1 503 595 6565

USA, Southwest – Houston, TX

+1 713 461 3495

Aerospace Hub Airframe

+1 303 469 1357

Aerospace Hub Distribution & Engineering

+1 260 749 9631

Aerospace Hub East

+1 610 828 3209

Aerospace Hub West

+1 310 371 1025

Automotive Hub North America

+1 734 354 1250

Automotive Hub South America

+55 12 3932 7600

ASIA PACIFIC

Asia Pacific Regional

+65 6 577 1778

China – Hong Kong

+852 2366 9165

China – Shanghai

+86 (0) 21 6145 1830

India – Bangalore

+91 (0) 80 3372 9000

Japan – Tokyo

+81 (0) 3 5633 8008

Korea – Seoul

+82 (0) 2 761 3471

Malaysia – Kuala Lumpur

+60 (0) 3 90549266

Taiwan – Taichung

+886 4 2382 8886

Vietnam – Ho Chi Minh City

+84 8 6288 6407

Singapore and all other countries in South and East Asia, Australasia

+65 6 577 1778

Aerospace Hub China

+86 (0) 21 6145 1830

Aerospace Hub Singapore

+65 6 577 1778

Automotive Hub China

+86 (0) 21 6145 1830

Automotive Hub India

+91 (0) 80 3372 9200

AFRICA, CENTRAL ASIA AND MIDDLE EAST

Africa & Iran (excluding South Africa (see UK))

+41 (0) 21 631 41 11

Central Asia (Armenia, Georgia, Kazakhstan,

Kyrgyzstan, Tajikistan, Uzbekistan)

+7 495 627 57 22

Middle East and Gulf Region

+359 (0) 2 969 95 99



Trelleborg is a world leader in engineered polymer solutions that seal, damp and protect critical applications in demanding environments. Its innovative engineered solutions accelerate performance for customers in a sustainable way. The Trelleborg Group has local presence in over 40 countries around the world.



facebook.com/TrelleborgSealingSolutions
twitter.com/TrelleborgSeals
youtube.com/TrelleborgSeals
flickr.com/TrelleborgSealingSolutions



WWW.TSS.TRELLEBORG.COM